

## 1000 KSPS, 3.3 V – 4.8 V, ULTRA LOW POWER, 12-BIT SAR ANALOG-TO-DIGITAL CONVERTER

### FEATURES

- 12-Bit Resolution
- Low Power (XC2360A typical):
  - 2.30mW (3.3V, 1000KSPS)
  - 10.0mW (4.5V, 1000KSPS)
- Single 3.3 V to 4.8 V Supply Operation for XC2360A
- Fast Throughput Rate:
  - 1000 KSPS for XC2360A
- $\pm 1.5\text{LSB INL}$ ,  $\pm 1.5\text{LSB DNL}$
- No Data Latency
- SPI/ MICROWIRE™ Compatible Serial Interface
- Guaranteed Operation from  $-40^{\circ}\text{C}$  to  $85^{\circ}\text{C}$
- 6-Pin SOT-23 Package
- Second-Source for LTC2360

### DESCRIPTION

The XC2360A is a 12-bit, high speed, low power, and small-sized Successive-Approximation-Register (SAR) ADC. The supply current drops at lower sampling rate because the devices automatically power down after conversions. The full-scale input of the XC2360A is 0V to VDD or VREF. This device can operate from a single 3.3 V to 4.8 V supply with a 1000 KSPS throughput.

The XC2360A is available in a 6-pin SOT-23 package and has an operating temperature range of  $-40^{\circ}\text{C}$  to  $85^{\circ}\text{C}$ .

**The XC2360A is a drop-in replacement for the LTC2360 and consumes only one third dynamic power of their counterpart.**

### APPLICATIONS

- Communication Systems
- Data Acquisition Systems
- Handheld Portable Devices
- Uninterrupted Power Supplies
- Battery-Operated Systems
- Automotive

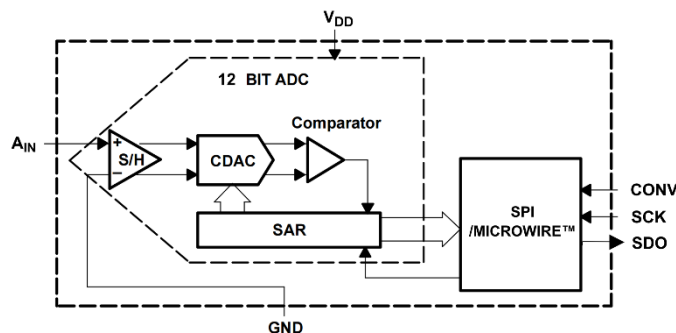

Figure 1. Functional Block Diagram

## SPECIFICATIONS

At -40°C to 85°C,  $f_{\text{SAMPLE}} = 1000$  KSPS and  $f_{\text{SCLK}} = 20$  MHz if  $3.3 \text{ V} \leq V_{\text{DD}} \leq 4.8 \text{ V}$ . (unless otherwise noted)

PARAMETER	TEST CONDITIONS	XC2360A			XC2361A			XC2362A			UNITS
		MIN	TYP	MAX	MIN	TYP	MAX	MIN	TYP	MAX	
<b>SYSTEM PERFORMANCE</b>											
Resolution		12			12			12			Bits
No missing codes		12			12			12			Bits
Integral linearity		1.5			1.5			1.5			LSB
Differential linearity		1.5			1.5			1.5			LSB
$f_{\text{SAMPLE}}$ Throughput rate	$3.3 \text{ V} \leq V_{\text{DD}} \leq 4.8 \text{ V}$	1000			1000			1000			KSPS
SNR	$f_{\text{IN}} = 100 \text{ kHz}$	72.4			72.4			72.4			dB
THD	$f_{\text{IN}} = 100 \text{ kHz}$	-84			-84			-84			dB

## XC2360A

PARAMETER	TEST CONDITIONS		MIN	TYP	MAX	UNITS
$I_{\text{DD}}$ Supply current, normal operation	Digital inputs = 0 V or $V_{\text{DD}}$	$f_{\text{SAMPLE}} = 1000$ KSPS, $f_{\text{SCLK}} = 20$ MHz, $V_{\text{DD}} = 3.3 \text{ V}$		0.72	1.56	mA
		$f_{\text{SAMPLE}} = 1000$ KSPS, $f_{\text{SCLK}} = 20$ MHz, $V_{\text{DD}} = 4.5 \text{ V}$		2.22	3.44	
		$f_{\text{SAMPLE}} = 800$ KSPS, $f_{\text{SCLK}} = 16$ MHz, $V_{\text{DD}} = 3.3 \text{ V}$		0.60	1.28	
		$f_{\text{SAMPLE}} = 800$ KSPS, $f_{\text{SCLK}} = 16$ MHz, $V_{\text{DD}} = 4.5 \text{ V}$		1.80	2.80	
<b>POWER DISSIPATION, XC2360A</b>						
Normal operation	$f_{\text{SAMPLE}} = 1000$ KSPS, $f_{\text{SCLK}} = 20$ MHz, $V_{\text{DD}} = 3.3 \text{ V}$			2.40	5.15	mW
	$f_{\text{SAMPLE}} = 1000$ KSPS, $f_{\text{SCLK}} = 20$ MHz, $V_{\text{DD}} = 4.5 \text{ V}$			10.0	15.5	

## PIN CONFIGURATION AND FUNCTION DESCRIPTIONS

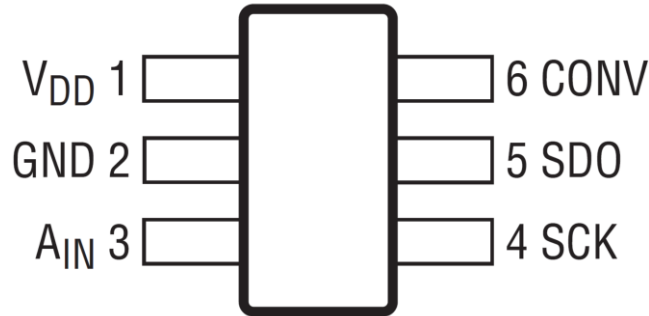

Figure 2. Pin Configuration

TERMINAL		DESCRIPTION
NAME	NO.	
V <sub>DD</sub>	1	Power Supply Input.
GND	2	The ground return for the supply and signals.
A <sub>IN</sub>	3	Analog Input. This signal can range from 0 V to V <sub>DD</sub> .
SCK	4	Digital clock input. This clock directly controls the conversion and readout processes.
SDO	5	Digital data output. The output samples are clocked out of this pin on falling edges of the SCK pin.
CONV	6	Chip Select. On the falling edge of CONV, a conversion process begins.

## TYPICAL CONNECTION

Figure 3 shows a typical connection diagram for the XC2360A. The 3.3 V supply should come from a stable power supply such as an LDO. The supply to XC2360A should be decoupled to the ground. A 1- $\mu$ F and a 10-nF decoupling capacitor are required between the V<sub>DD</sub> and GND pins of the converter. Those capacitors should be placed as close as possible to the pins of the device. Always set the V<sub>DD</sub> supply to be greater than or equal to the maximum input signal to avoid saturation of codes.

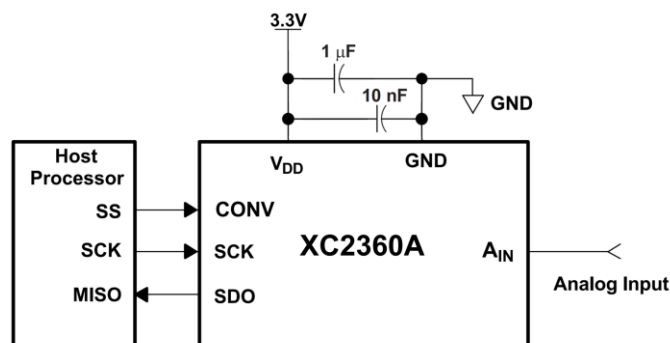

Figure 3. Typical Circuit Configuration

## TIMING DIAGRAM

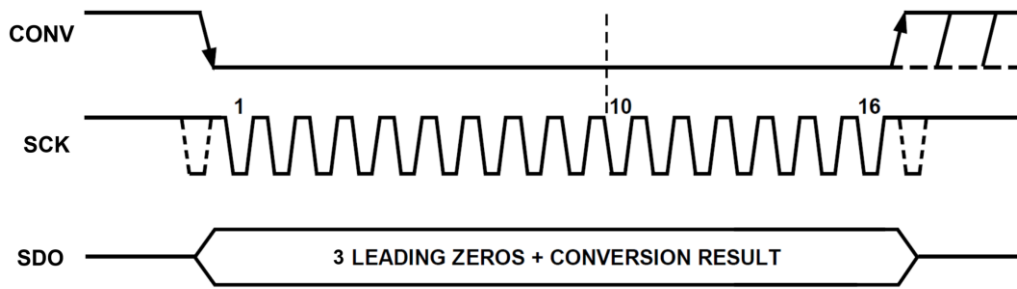

Figure 4. Timing Diagram

This is different from LTC2360 which outputs the conversion result through SDO immediately after the falling edge of the CONV. The XC2360A outputs a 12-bit conversion result from SDO after the fourth SCK falling edge after the CONV falling edge, after which the SDO enters a three-state and the conversion cycle ends. The XC2360A data word contains 3 leading zeros, followed by 12-bit data in MSB first format. Higher SCLK frequencies reduce the acquisition time and conversion time. This means the converters spend more time in auto power-down mode per conversion cycle.

## CONVERSION RESULT

The XC2360A outputs 12-bit data after 3 leading zeros, respectively. These codes are in straight binary format.

DESCRIPTION	ANALOG INPUT VOLTAGE	DIGITAL OUTPUT STRAIGHT BINARY	
		BINARY CODE	HEX CODE
<b>XC2360A (12bit)</b>			
Least Significant Bit (LSB)	$V_{DD}/4096$		
Full Scale	$V_{DD} - 1\text{LSB}$	1111 1111 1111	FFF
Mid Scale	$V_{DD}/2$	1000 0000 0000	800
Mid Scale - 1LSB	$V_{DD}/2 - 1\text{LSB}$	0111 1111 1111	7FF
Zero	0V	0000 0000 0000	000

There is no specific initialization requirement for these converters after power-on, but the first conversion might not yield a valid result. In order to set the converter in a known state, CONV should be toggled low then high after  $V_{DD}$  has stabilized during power-on. By doing this, the converter is placed in auto power-down mode, and the serial data output (SDO) is three-stated.

## OUTLINE DIMENSIONS

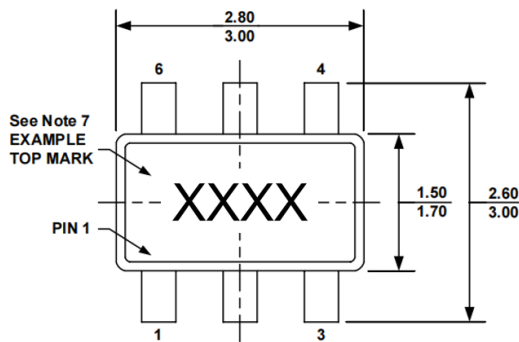

**TOP VIEW**

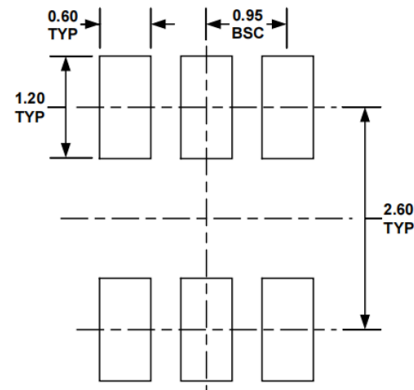

**RECOMMENDED LAND PATTERN**

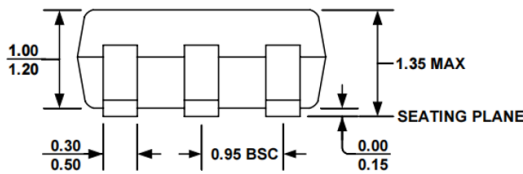

**FRONT VIEW**

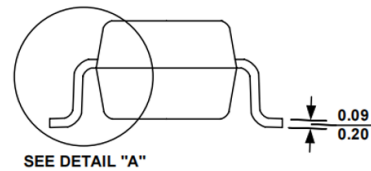

**SIDE VIEW**

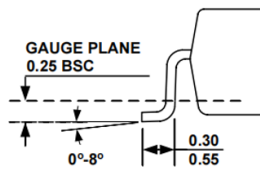

**DETAIL "A"**

**NOTE:**

- 1) ALL DIMENSIONS ARE IN MILLIMETERS.
- 2) PACKAGE LENGTH DOES NOT INCLUDE MOLD FLASH, PROTRUSION OR GATE BURR.
- 3) PACKAGE WIDTH DOES NOT INCLUDE INTERLEAD FLASH OR PROTRUSION.
- 4) LEAD COPLANARITY (BOTTOM OF LEADS AFTER FORMING) SHALL BE 0.10 MILLIMETERS MAX.
- 5) DRAWING CONFORMS TO JEDEC MO-178, VARIATION AB.
- 6) DRAWING IS NOT TO SCALE.
- 7) PIN 1 IS LOWER LEFT PIN WHEN READING TOP MARK FROM LEFT TO RIGHT, (SEE EXAMPLE TOP MARK)

## NOTES

1. Unpacked ICs, tube-mounted ICs, etc. must be stored in a drying cabinet, and the humidity in the drying cabinet < 20% R.H.
2. After access, the components are stored in an electrostatic packaging protective bag.
3. Anti-static damage: the device is an electrostatic sensitive device, and sufficient anti-static measures should be taken during transmission, assembly and testing.
4. The user should conduct a visual inspection before use, and the bottom, side and surrounding of the circuit can be welded only if it is bright. If oxidation occurs, the circuit can be processed by means of oxidation, and the circuit must be soldered within 12 hours after processing.