

■ Product introduction

XC6219 series is a high precision, low noise and fast response low dropout linear voltage regulator manufactured by CMOS process. This series of voltage regulators has built - in fixed reference voltage, error correction circuit, current limiting circuit, phase compensation circuit and MOSFET with low internal resistance, which achieves high ripple suppression, low output noise and quick response to low dropout.

XC6219 series is compatible with ceramic capacitors with smaller volume than tantalum capacitors, and does not need to use 0.1 μF By-pass capacitors, which can save space and reduce cost. Because of its high -precision output stability and fast transient response, it can cope with the fluctuation of load current, so it is especially suitable for handheld devices and RF products.

By controlling the CE pin on the chip, the output can be turned off, and the static current after turning off the output is only 0.1uA(Typ value), thus greatly reducing the power consumption.

■ Product features

- High precision output voltage: 2.5%;
- Selectable output voltage: 1.8V~5.0V;
- Very low static current (Typ.=15μ A);
- Very low turn -off current (Typ.=0.1 μ A);
- Good input stability: Typ.=0.2%/V;
- Strong carrying capacity:when Vin=4.3V and Vout=3.3V, Iout=300mA
- Built - in overcurrent protection and load short circuit protection;
- Compatible ceramic capacitor;
- Package form: SOT89-5, SOT23-5

■ product usage

- Smart phone/mobile phone
- Digital camera/video camera
- Battery powered equipment
- Bluetooth and other RF products
- Portable consumer equipment

■ Package form and pin definition function

Pin serial number		Pin definition	function declaration
MR package	PR package		
SOT23-5	SOT89-5		
1	4	VIN	Input
2	2	VSS	Grounding terminal
3	3	CE	Enable side
4	1	NC	empty
5	5	VOUT	Output

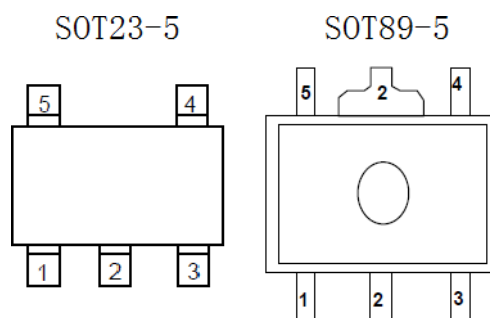

■ Model Description

XC6219B

Number represents	Describe	Symbol	Describe
	Output voltage	15-36	: e.g. V _{OUT} 1.5V =1, =5
	Output accuracy	± 2.5%	: e.g. V _{OUT} 1.5V→③=2, is: 152
	Package	M	: SOT23-5
		P	: SOT89-5
	Tape	R	: Embossed tape, standard inflow

■ functional block diagram

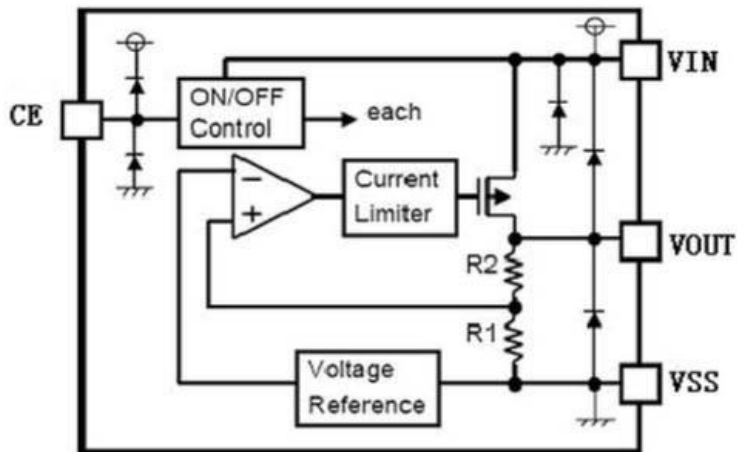

■ Limit parameter

project	symbol	explain		limit value	unit
voltage	Vin	input voltage		9	V
	Vout	Output voltage		$V_{ss}-0.3 \sim V_{in}+0.3$	V
electric current	Iout	output current		500	mA
Power Consumption	PD	SOT23-5	Maximum allowable power consumption	250	mW
		SOT89-5		350	
Temperature	T _{OPR}	Working temperature		- 40~ +85	°C
	T _{stg}	Storage temperature		- 40~ +125	°C
	T _{solder}	welding temperature		260°C, 10s	

Note: The limit parameter refers to the limit value that can't be exceeded under any conditions. If it exceeds this limit value, it may cause physical damage such as product deterioration; At the same time, when the parameters are close to the limit, the chip can't work normally.

■ Typical application

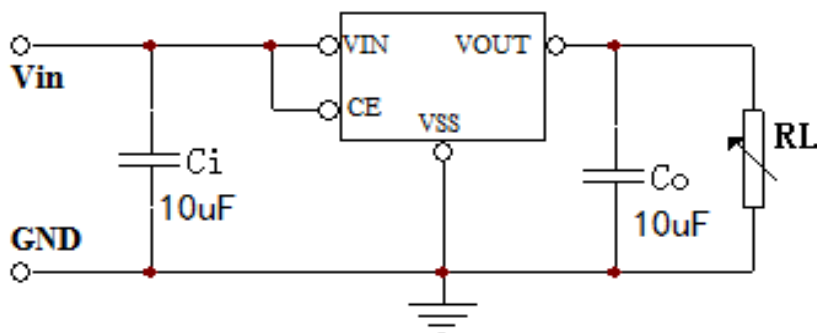

Electrical characteristics

 XC6219 $V_{OUT}(T)=3.0V$

 ($C_i=C_o=10\mu F, T_a=25^\circ C$ unless otherwise specified)

trait	symbol	test condition	minimum value	typical value	maximum	unit
Output voltage	$V_{OUT}(E)$	$I_{OUT}=1mA, V_{IN}=5V, V_{CE}=1.6V$	2.925	3.00	3.075	V
Maximum output current	$I_{OUT} (max)$	$V_{IN}= 4 V$		300		mA
Load stability	ΔV_{OUT}	$V_{IN}=V_{CE}=4V, 1mA \leq I_{OUT} \leq 100mA$		12		mV
Input stability	$\Delta V_{OUT}/(\Delta V_{IN} \bullet V_{OUT})$	$I_{OUT} = 10mA, 4V \leq V_{IN} \leq 7V$		0.2		%/V
Drop pressure difference	V_{drop1}	$V_{IN}=4 V, I_{OUT}=10mA$		35		mV
	V_{drop2}	$V_{IN}=4 V, I_{OUT} =100mA$		280		mV
quiescent current	I_{SS1}	$V_{IN}=V_{CE}=5V$	—	15	—	μA
	I_{SS2}	$V_{IN}=5V, V_{CE}=V_{SS}$			0.5	μA
CE input voltage	V_{CEH}		1.6		V_{IN}	V
	V_{CEL}		0		0.5	V
CE input current	I_{CE}	$V_{CE}=0V$ to V_{IN}			0.5	μA
Ripple suppression ratio	PSRR	$V_{IN}=V_{CE}=4V+1V_{p-pAC}$ $I_{OUT}=10mA, f=1kHz$		40		dB
Output voltage temperature coefficient	$\Delta V_{OUT}/(\Delta T_a \bullet V_{OUT})$	$V_{IN}=V_{CE}=4V, I_{OUT}=3mA$ $0^\circ C \leq T_a \leq 60^\circ C$		± 290		ppm/ $^\circ C$
input voltage	V_{IN}		1.8		7	V

Note:

1. $V_{OUT}(T)$: the specified output voltage.
2. $V_{OUT}(E)$: effective output voltage.
3. $I_{OUT}(max)$: Slowly increase the output current to the current value when the output voltage is $\leq V_{OUT}(E) * 95\%$.
4. $V_{drop} = V_{IN1} - V_{OUT}(E)$
 V_{IN1} =gradually decrease the input voltage until the output voltage drops to 98% of $V_{OUT}(E)$ 1.
 $V_{OUT}(E)s = V_{OUT}(E)1 * 98\%$
 $V_{OUT}(E)1$ =the output voltage value when $V_{IN}=V_{OUT}(T)+1V$ and I_{out} =a certain value.

Electrical characteristics

 XC6219 $V_{OUT}(T)=3.3V$ ($C_i=C_o=10\mu F, T_a=25^\circ C$ unless otherwise specified)

trait	symbol	test condition	minimum value	typical value	maximum	unit
Output voltage	$V_{OUT}(E)$	$I_{OUT}=1mA, V_{IN}=5V, V_{CE}=1.6V$	3.217	3.300	3.382	V
Maximum output current	$I_{OUT} (max)$	$V_{IN}=4.3V$		300		mA
Load stability	ΔV_{OUT}	$V_{IN}=V_{CE}=4.3V, 1mA \leq I_{OUT} \leq 100mA$		12		mV
Input stability	$\Delta V_{OUT}/(\Delta V_{IN} \bullet V_{OUT})$	$I_{OUT} = 10mA, 4.3V \leq V_{IN} \leq 7V$		0.2		%/V
Drop pressure difference	V_{drop1}	$V_{IN}=4.3V, I_{OUT}=10mA$		35		mV
	V_{drop2}	$V_{IN}=4.3V, I_{OUT} = 100mA$		280		mV
quiescent current	I_{SS1}	$V_{IN}=V_{CE}=5V$	—	15	—	μA
	I_{SS2}	$V_{IN}=5V, V_{CE}=V_{SS}$			0.5	μA
CE input voltage	V_{CEH}		1.6		V_{IN}	V
	V_{CEL}		0		0.5	V
CE input current	I_{CE}	$V_{CE}=0V$ to V_{IN}			0.5	μA
Ripple suppression ratio	PSRR	$V_{IN}=V_{CE}=4.3V+1V_{p-pAC}$ $I_{OUT}=10mA, f=1kHz$		40		dB
Output voltage temperature coefficient	$\Delta V_{OUT}/(\Delta T_a \bullet V_{OUT})$	$V_{IN}=V_{CE}=4.3V, I_{OUT}=3.3mA$ $0^\circ C \leq T_a \leq 60^\circ C$		± 290		ppm/ $^\circ C$
input voltage	V_{IN}		1.8		7	V

Note:

- $V_{OUT}(T)$: the specified output voltage.
- $V_{OUT}(E)$: effective output voltage.
- $I_{OUT}(max)$: Slowly increase the output current to the current value when the output voltage is $\leq V_{OUT}(E) * 95\%$.
- $V_{drop}=V_{IN1}-V_{OUT}(E)$

V_{IN1} =gradually decrease the input voltage until the output voltage drops to 98% of $V_{OUT}(E)$ 1. $V_{OUT}(E)$ s = $V_{OUT}(E) * 98\%$;

$V_{OUT}(E) 1$ =the output voltage value when $V_{IN}=V_{OUT}(T)+1V$ and I_{out} =a certain value.

■ Characteristic curve (3.3V output)

1. Output voltage and output current

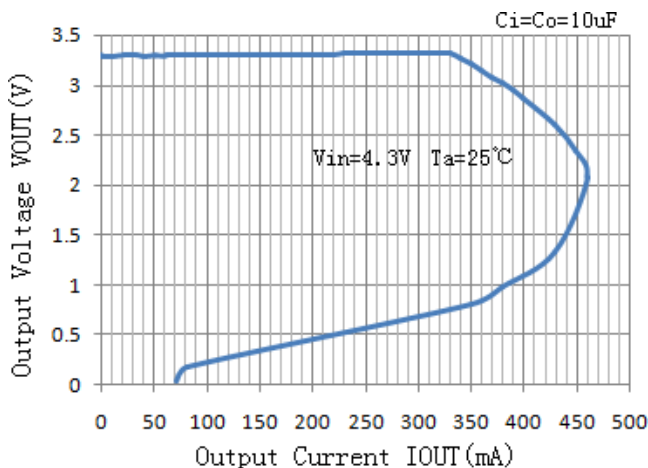

2. Output voltage and input voltage

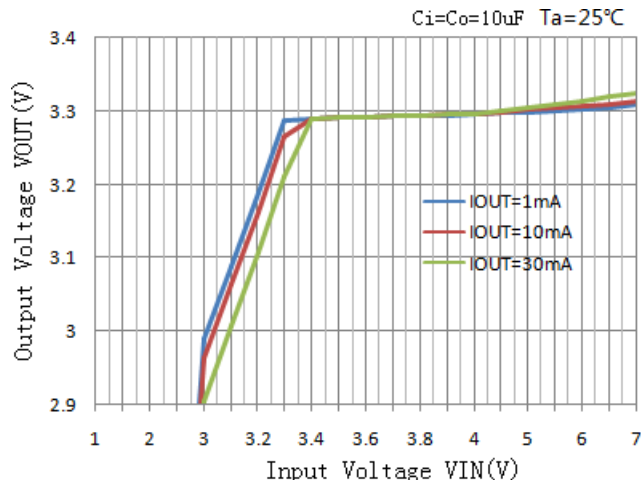

3. Dropout voltage and output current

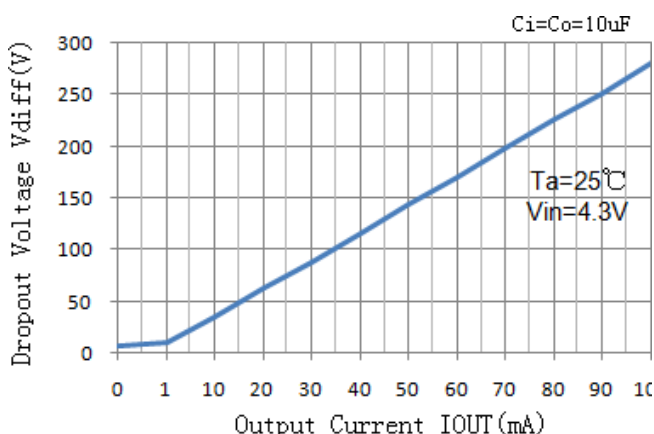

4. Input voltage and static current

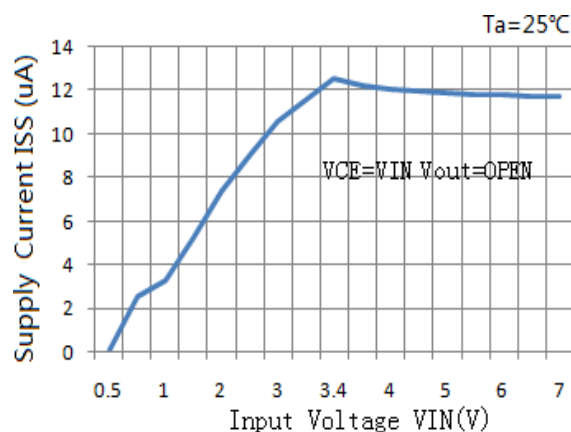

5. Ripple suppression

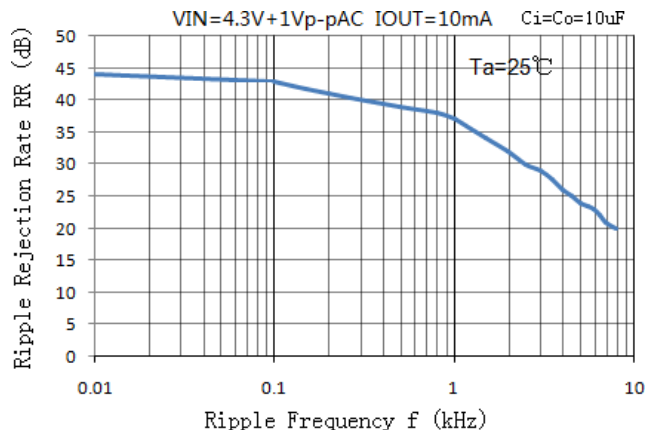

6. Output voltage and temperature

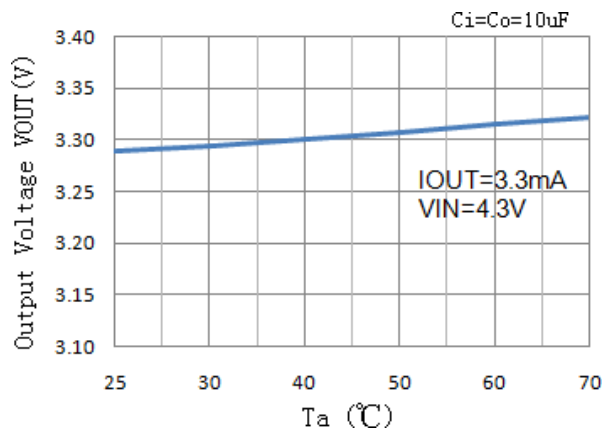

■ Package Information

SOT23-5

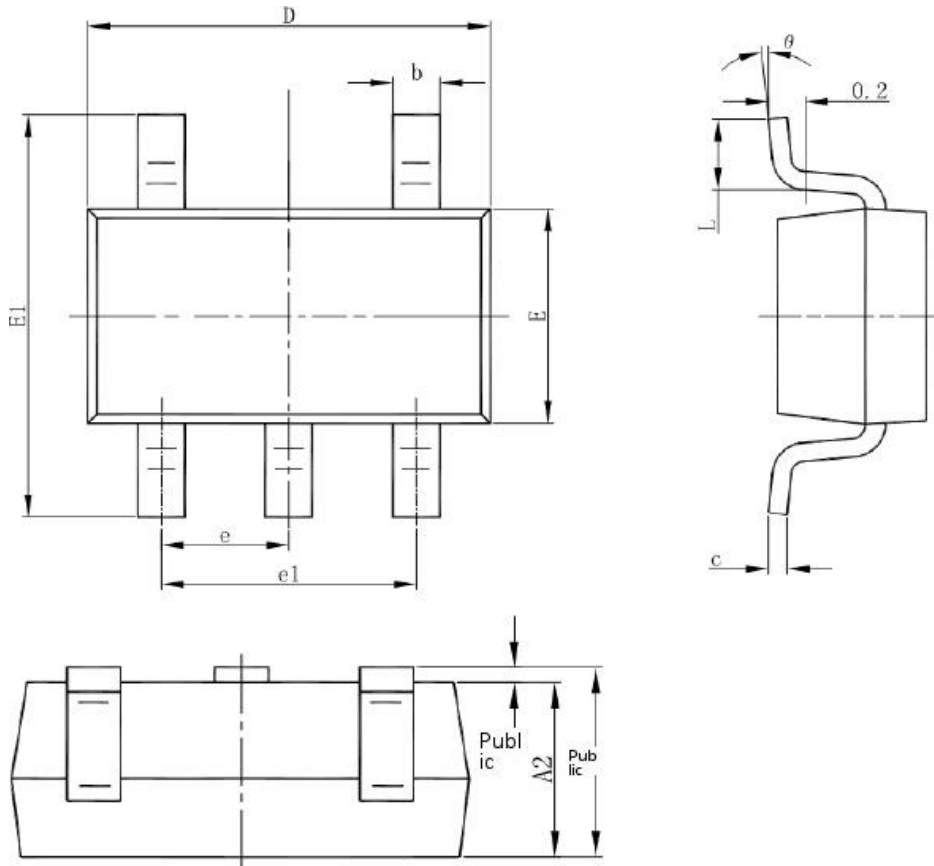

Symbol	Dimensions In Millimeters		Dimensions In Inches	
	Min	Max	Min	Max
A	1.050	1.250	0.041	0.049
A1	0.000	0.100	0.000	0.004
A2	1.050	1.150	0.041	0.045
b	0.300	0.500	0.012	0.020
c	0.100	0.200	0.004	0.008
D	2.820	3.020	0.111	0.119
E	1.500	1.700	0.059	0.067
E1	2.650	2.950	0.104	0.116
e	0.950(BSC)		0.037(BSC)	
e1	1.800	2.000	0.071	0.079
L	0.300	0.600	0.012	0.024
θ	0°	8°	0°	8°

SOT89-5

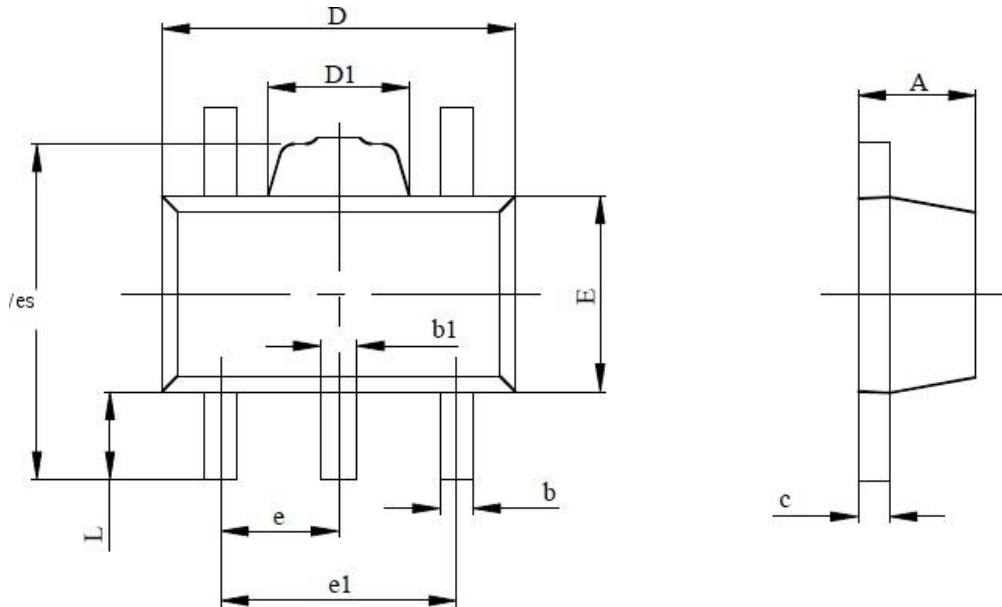

SYMBOL	MILLIMETERS		INCHES	
	MIN	MAX	MIN	MAX
A	1.400	1.600	0.055	0.063
b	0.320	0.520	0.013	0.020
b1	0.360	0.560	0.014	0.022
c	0.350	0.440	0.014	0.017
D	4.400	4.600	0.173	0.181
D1	1.400	1.800	0.055	0.071
E	2.300	2.600	0.091	0.102
E1	3.940	4.250	0.155	0.167
e	1.500 TYP.		0.060 TYP.	
e1	2.900	3.100	0.114	0.122
L	0.900	1.100	0.035	0.043

Ordering information

Oder Code	Package	Base qty	Deliverymode	Marking	Vout (V)
UMW XC6219B152MR	SOT23-5	3000	Tape and Reel	LXEK	1.5
UMW XC6219B182MR	SOT23-5	3000	Tape and Reel	LXKK	1.8
UMW XC6219B252MR	SOT23-5	3000	Tape and Reel	LXTK	2.5
UMW XC6219B282MR	SOT23-5	3000	Tape and Reel	LXXK	2.8
UMW XC6219B302MR	SOT23-5	3000	Tape and Reel	LXZK	3.0
UMW XC6219B332MR	SOT23-5	3000	Tape and Reel	LB2K	3.3
UMW XC6219B362MR	SOT23-5	3000	Tape and Reel	LB5K	3.6
UMW XC6219B502MR	SOT23-5	3000	Tape and Reel	LBMK	5.0
UMW XC6219B152PR	SOT89-5	3000	Tape and Reel	LXEK	1.5
UMW XC6219B182PR	SOT89-5	3000	Tape and Reel	LXKK	1.8
UMW XC6219B252PR	SOT89-5	3000	Tape and Reel	LXTK	2.5
UMW XC6219B282PR	SOT89-5	3000	Tape and Reel	LXXK	2.8
UMW XC6219B302PR	SOT89-5	3000	Tape and Reel	LXZK	3.0
UMW XC6219B332PR	SOT89-5	3000	Tape and Reel	LB2K	3.3
UMW XC6219B362PR	SOT89-5	3000	Tape and Reel	LB5K	3.6
UMW XC6219B502PR	SOT89-5	3000	Tape and Reel	LBMK	5.0