

REVISIONS				
P.	LTN.	DESCRIPTION	DATE	APVD.
D		REV PER ECO 16-006664	5-2-16	CT MS
E		REV PER ECO-16-009404	30JUN2016	KG MS

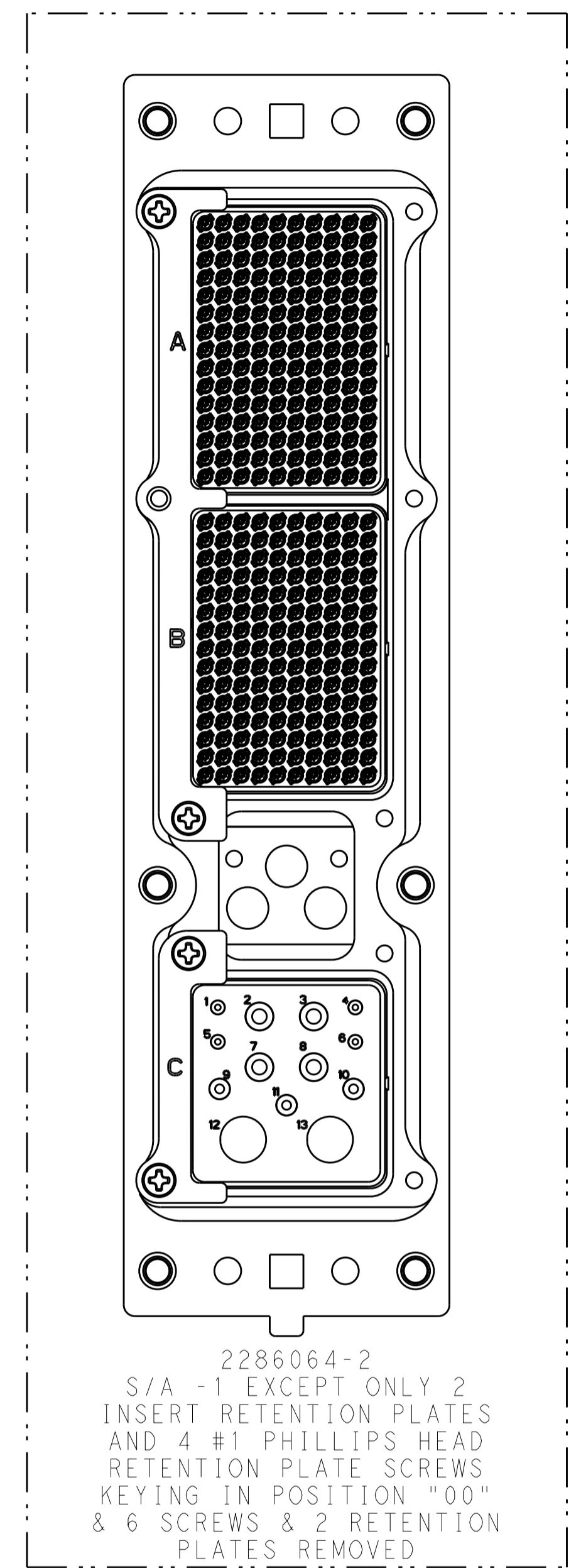
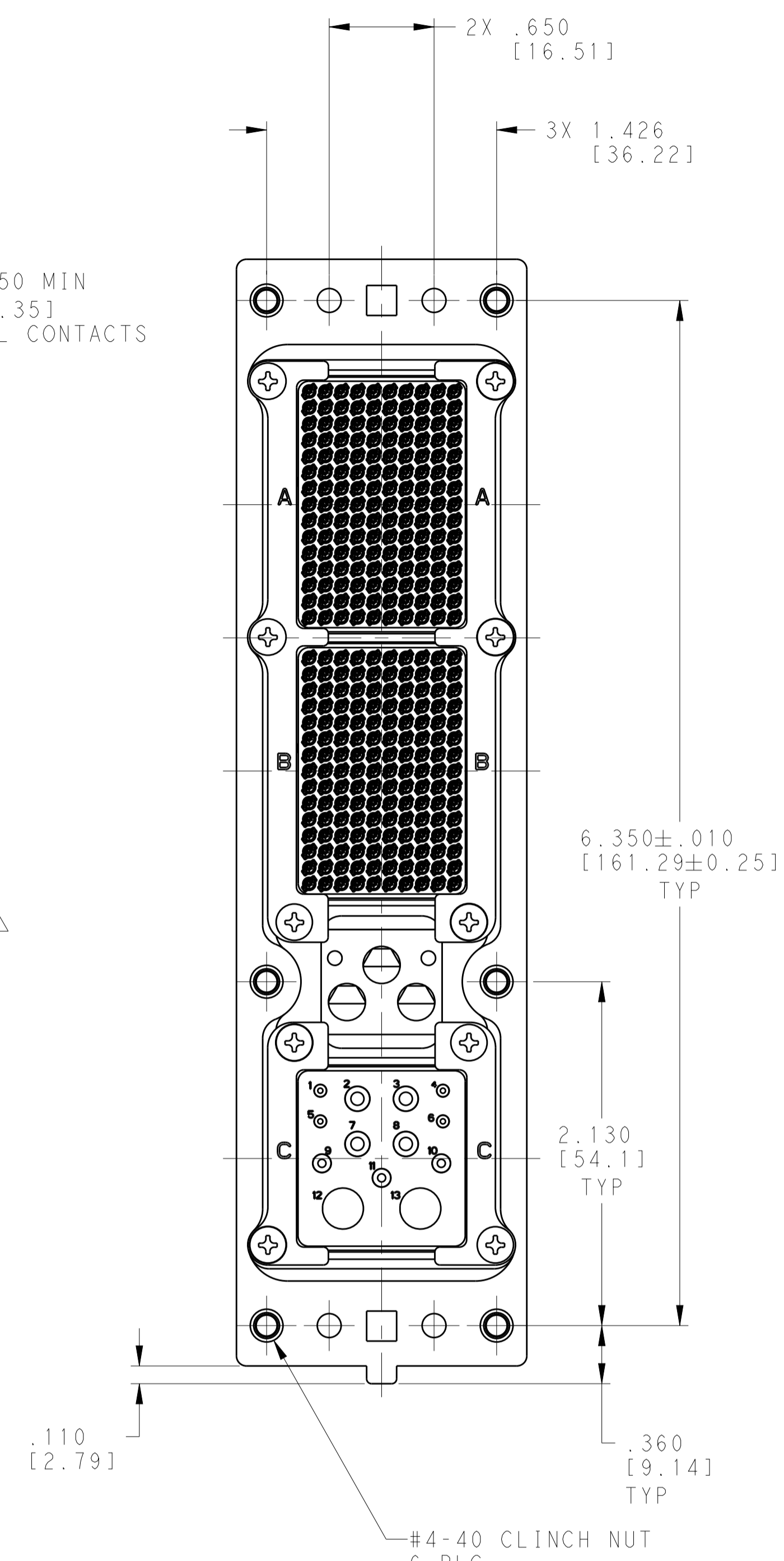
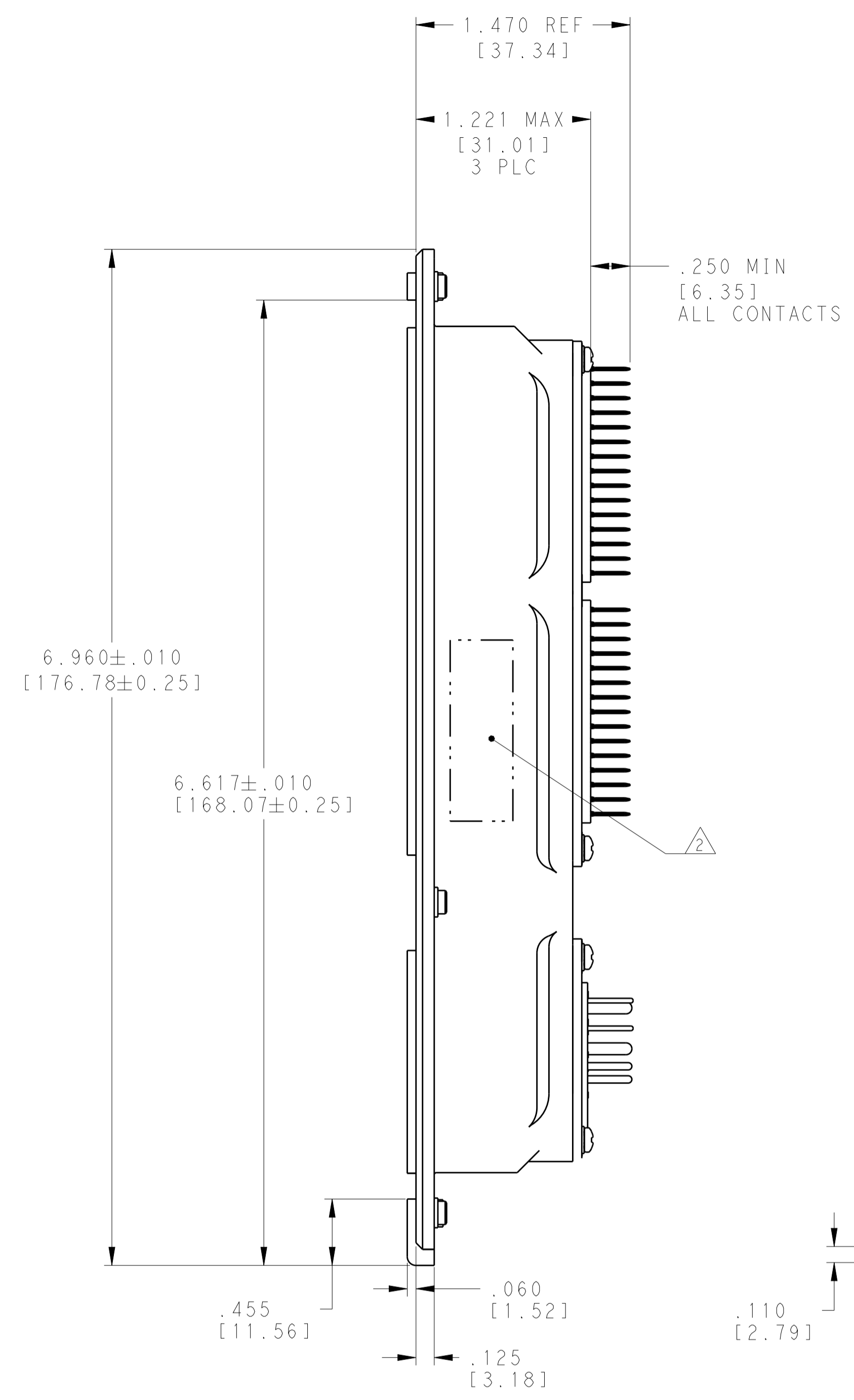
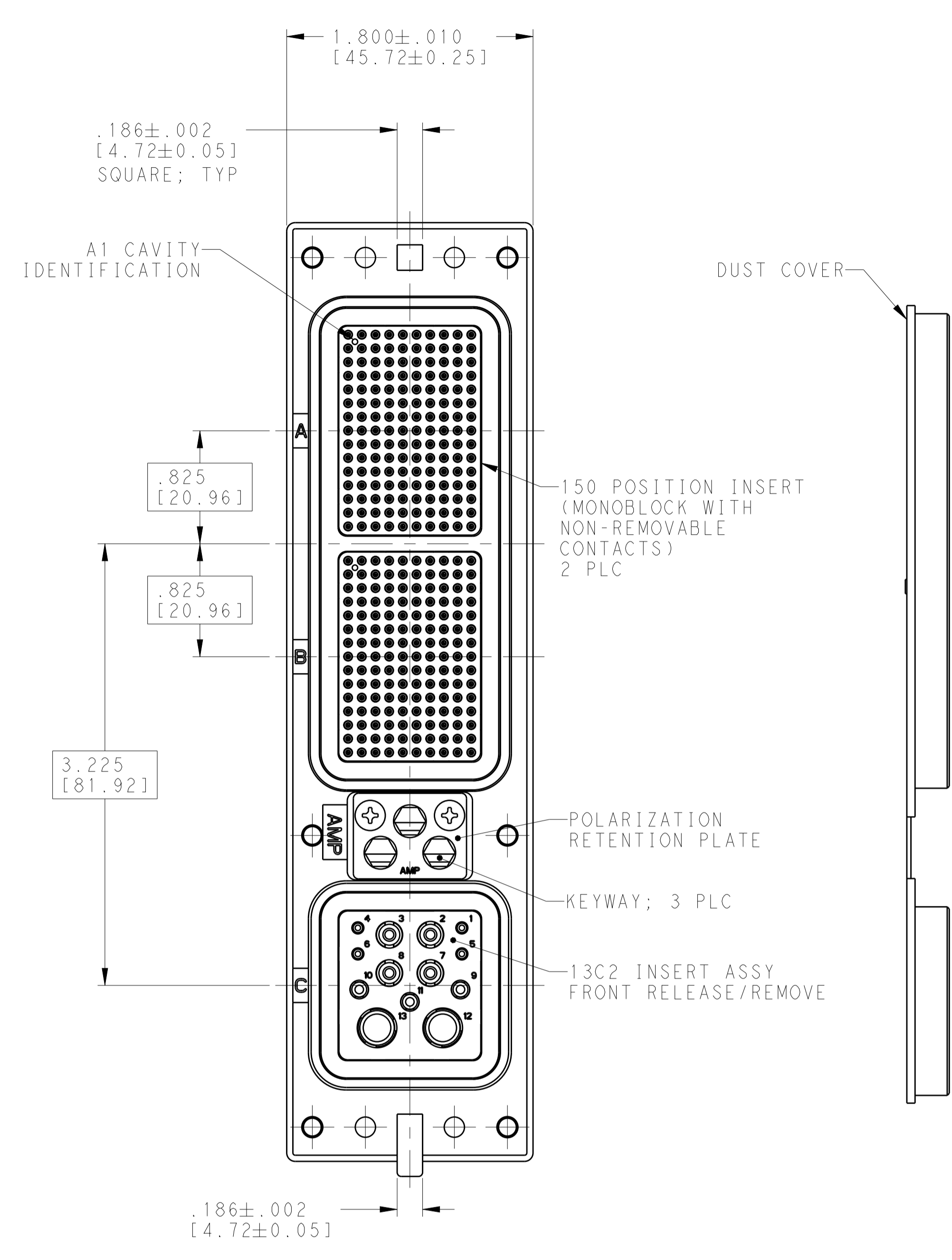

COMPONENT	MATERIAL	FINISH	REMARKS
SIZE 22 STAMPED AND FORMED SOCKET CONTACTS QTY = 300	BODY: COPPER ALLOY HOOD: STAINLESS STEEL	BODY: .000050 [0.00127] MIN GOLD ON MATING TINES, Sn ON TAIL OVER NICKEL PLATE $\triangle$ HOOD: PASSIVATED	NON REMOVEABLE (150 POSN. INSERTS) $\triangle$
150 POSITION MONOBLOCK INSERT 2 PLC	THERMOPLASTIC	NONE	ONE PIECE DESIGN WITH NON-REMOVABLE CONTACTS $\triangle$
13C2 POSITION INSERT	THERMOSET	--	ALL FRONT RELEASE/REMOVE
POLARIZATION KEYWAY	ZINC ALLOY PER ASTM-B-86	--	--
#4-40 CLINCH NUTS 6 PLC	STEEL	ZINC PLATE WITH SUPPLEMENTAL YELLOW TRIVALENT CHROMATE COATING	--
KEYWAY RETAINER PLATE	ALUMINUM ALLOY	BLUE ANODIZED PER MIL-A-8625	--
SHELL AND RETENTION PLATES	ALUMINUM ALLOY PER ASTM-B-85 ALUMINUM ALLOY PER ASTM-B-209	ELECTROLESS NICKEL PER MIL-C-26074	--

$\triangle$  ASSEMBLED CONNECTOR FEATURES COMPLY WITH ARINC 600 SPECIFICATION EXCEPT AS NOTED.  
 $\triangle$  MANUFACTURERS PART NO. AND DATE CODE (YY-WW) MARKED IN AREA SHOWN.

- KEYING SHOWN IN POSITION "01" FOR REFERENCE ONLY. SEE TABLE FOR KEYING POSITION. FOR POSITION "00" KEYING SHIPPED UNASSEMBLED.
- THE FOLLOWING CONTACTS AND FILLER PLUGS FOR THE 13C2 POSITION INSERT ARE INCLUDED AND INSTALLED:  
 SIZE 20 POSTED PIN CONTACT; TE PART NO. 1-448138-2; QTY = 4  
 SIZE 16 POSTED PIN CONTACT; TE PART NO. 1-448139-1; QTY = 3  
 SIZE 12 POSTED PIN CONTACT; TE PART NO. 448140-3; QTY = 4  
 SIZE 5 FILLER PLUG; TE PART NO. 1484205-1; QTY = 2
- CONNECTOR IS SUPPLIED WITH A DUST COVER INSTALLED FOR SHIPPING.

KEYING POSITION	PART NUMBER
"00"	2286064-2
"01"	2286064-1

THIS DRAWING IS A CONTROLLED DOCUMENT. DIMENSIONS: [INCHES][mm]. TOLERANCES UNLESS OTHERWISE SPECIFIED: 0 PLC ±, 1 PLC ±, 2 PLC ±, 3 PLC ±, 4 PLC ±, ANGLES ±. MATERIAL: SEE TABLE. FINISH: SEE TABLE. WEIGHT: -. Customer Drawing. SCALE: 3:2. SHEET: 1 OF 1. REV: E.

APVD: W. BERNHART 2-26-14. NAME: RECEPTACLE ASSY, SIZE 2, ARINC 600 (150/150/13C2) WITH STAMPED AND FORMED SIGNAL CONTACTS. SIZE: A100779. CAGE CODE: 2286064. RESTRICTED TO: -. Customer Drawing.

**STE** TE Connectivity