

# VG6244S580X0M1 wireless module

## Hardware specification

V1.0

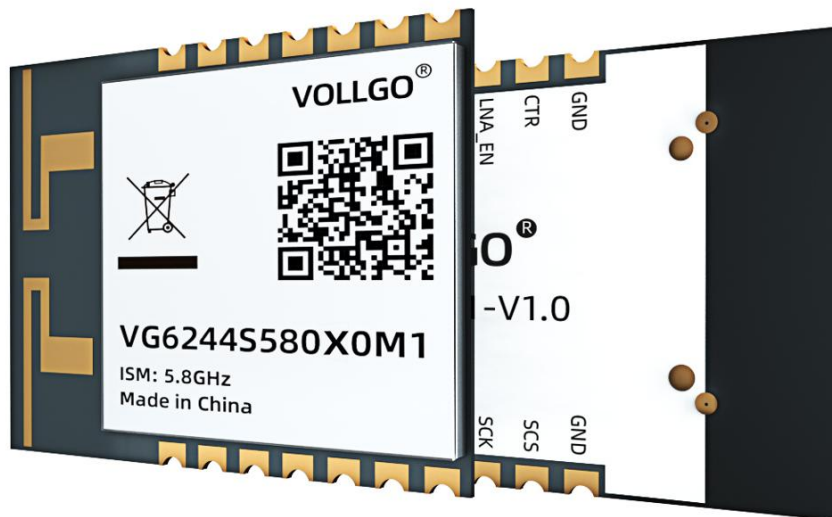

## Content

1. overview .....	3
2. Electrical Characteristics .....	5
3. Pin Location Diagram .....	6
4. Pin description .....	7
5. Hardware Design Guidance and Precautions .....	8
5.1 Application circuit .....	8
5.2, Power Supply Design and Related Precautions .....	8
5.3. Layout of Modules .....	9
6. Programming Development .....	10
7. reflow soldering curve .....	11
8. Static Damage Warning .....	12
9. encapsulation information .....	12
Mechanical dimensions (unit:mm) .....	12
10. version update .....	13
11. Purchase Selection Table .....	13
12. Statement .....	13
13. Contact Us .....	14

## 1. overview

VG6244S580X0M1 series wireless module is a 5.8GHz band bidirectional wireless transceiver module based on A5133 wireless transceiver chip design with small size and high transmission rate. The PA LNA amplifier is integrated inside the module, and the maximum power can reach 23dBm, which greatly improves the transmission distance of the module.

A5133 is an FSK wireless radio frequency transceiver chip operating in the 5.8GHz band. It supports independent 64bytes TX/RX FIFO. Its data transmission rate of up to 4Mbps is especially suitable for Internet of Things usage scenarios with low latency and large data transmission. In order to ensure the security of data transmission, A5133 has integrated AES128 encryption and decryption engine.

The module integrates all radio frequency related functions and devices. Users can easily develop wireless solutions and wireless Internet of Things devices with stable performance and high reliability without in-depth understanding of radio frequency circuit design.

### **Main features of the product:**

- 5.8GHz wireless transmission band
- 3-wire/4-wire SPI interface
- Programmable data transfer rate: 4Mbps/2Mbps/500Kbps
- Sleep current: 4uA
- Maximum transmit power: 23dBm
- Receiving sensitivity:-98dBm @ 4Mbps

- Built-in AES128 encryption engine
- Operating voltage: 4.5-5.2V

## **Application:**

- HiFi wireless audio
- Video and picture transmission
- Toys and gamepads
- Digital intercom

## 2. Electrical Characteristics

Parameter	Description	Remark
Power Supply	4.5~5.2V	General 5V
Frequency range	5.8GHz	5725MHz-5850MHz
Output power	23dBm	A5133 TX Power=0dBm
Crystal Frequency	500Kbps/2Mbps/4Mbps	Programmable configuration
RF Modulation	FSK	
Receive sensitivity	-98dBm	@ 4Mbps
TX Current	450mA	Transmit power = 23dBm
RX Current	40mA	@ 4Mbps
Sleep current	10uA	
Drive interface	SPI	3-wire or 4-wire SPI
Antenna Impedance	50 ohms	
Antenna connection	onboard PCB antenna	
Storage temperature	-55 °C ~ +125 °C	
Operating emperature	-40 °C ~ +85 °C	Industrial grade

Size	16.8x 21.5mm	
------	--------------	--

### 3. Pin Location Diagram

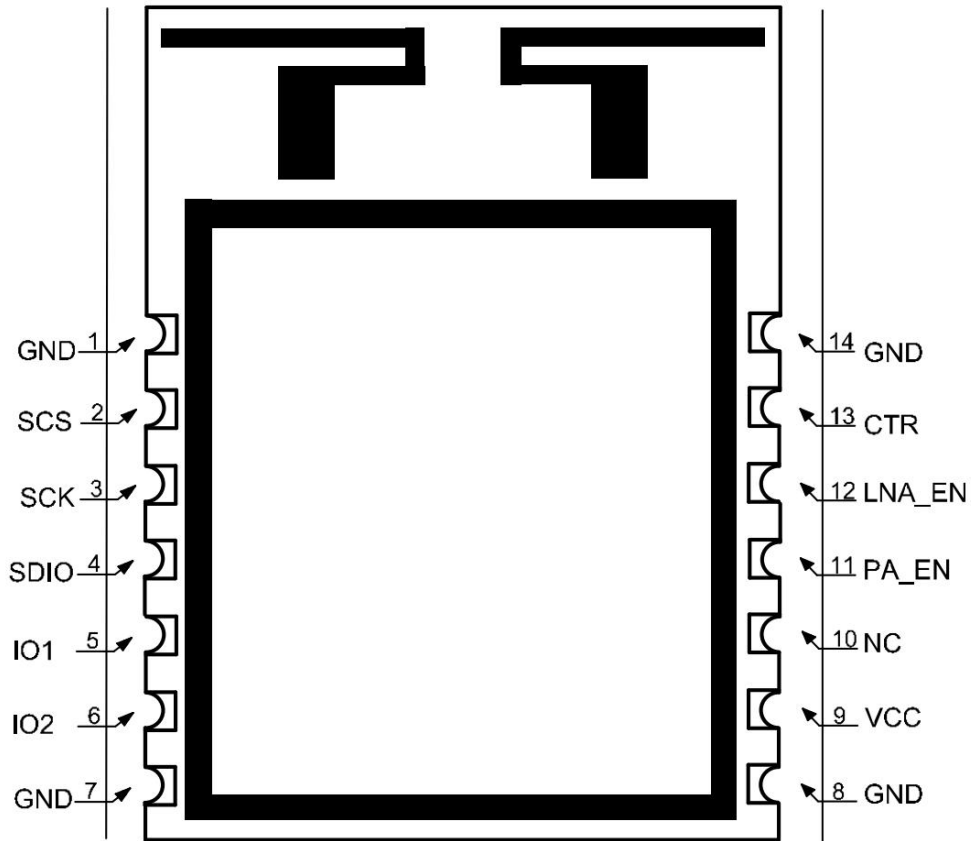

Figure 3-1 Top View

## 4. Pin description

Number	Name	Type	Description
1	GND	Land	Power supply ground
2	SCS	SPI film selection	SPI interface SPI chip selection
3	SCK	SPI clock	SPI interface clock input
4	SDIO	SPI data	SPI data input and output
5	IO1	I/O	Function programmable configuration (generally used as a complete instruction for sending and receiving data packets, see the chip manual for details)
6	IO2	I/O	Function programmable configuration (see chip manual for details)
7	GND	Land	Power supply ground
8	GND	Land	Power supply ground
9	VCC	Power Supply	Module power supply, general 5V input
10	GND	Land	Power supply ground
11	PA_EN	I	Module PA enable foot, transmit mode: PA_EN = 1,LNA_EN = 0,CTR = 0
12	LNA_EN	I	Module LNA enable foot, receiving mode: PA_EN = 0,LNA_EN = 1,CTR = 1
13	CTR	I	Module Receiving Control Foot, CTR1 in Receiving Mode
14	GND	Land	Power supply ground



an LDO will be added at the back 1 the isolation of the module power supply to prevent the noise of the switching power supply chip from interfering with the working performance of radio frequency.

5. If the communication line between MCU and module uses 5V level, 1K-5.1K resistors must be connected in series (not recommended, there is still risk of damage).

6. The radio frequency module should be kept away from high-voltage devices as far as possible, because the electromagnetic waves of high-voltage devices will also have a certain impact on radio frequency signals.

7. High-frequency digital wiring, high-frequency analog wiring and high-current power supply wiring should avoid the lower part of the module as far as possible. If it is necessary to pass through the lower part of the module, the wiring should be placed on the other layer of PCB bottom plate where the module is placed, and the copper layer under the module should be well grounded.

## 5.3 Layout of Modules

The radiation and reception of radio frequency signals are realized through antennas. The grounded copper skin has a strong absorption effect on radio frequency. Therefore, the PCB on-board antenna cannot be covered by copper skin on the bottom plate, nor can it be covered by batteries or other metal devices, otherwise the communication distance is greatly reduced.

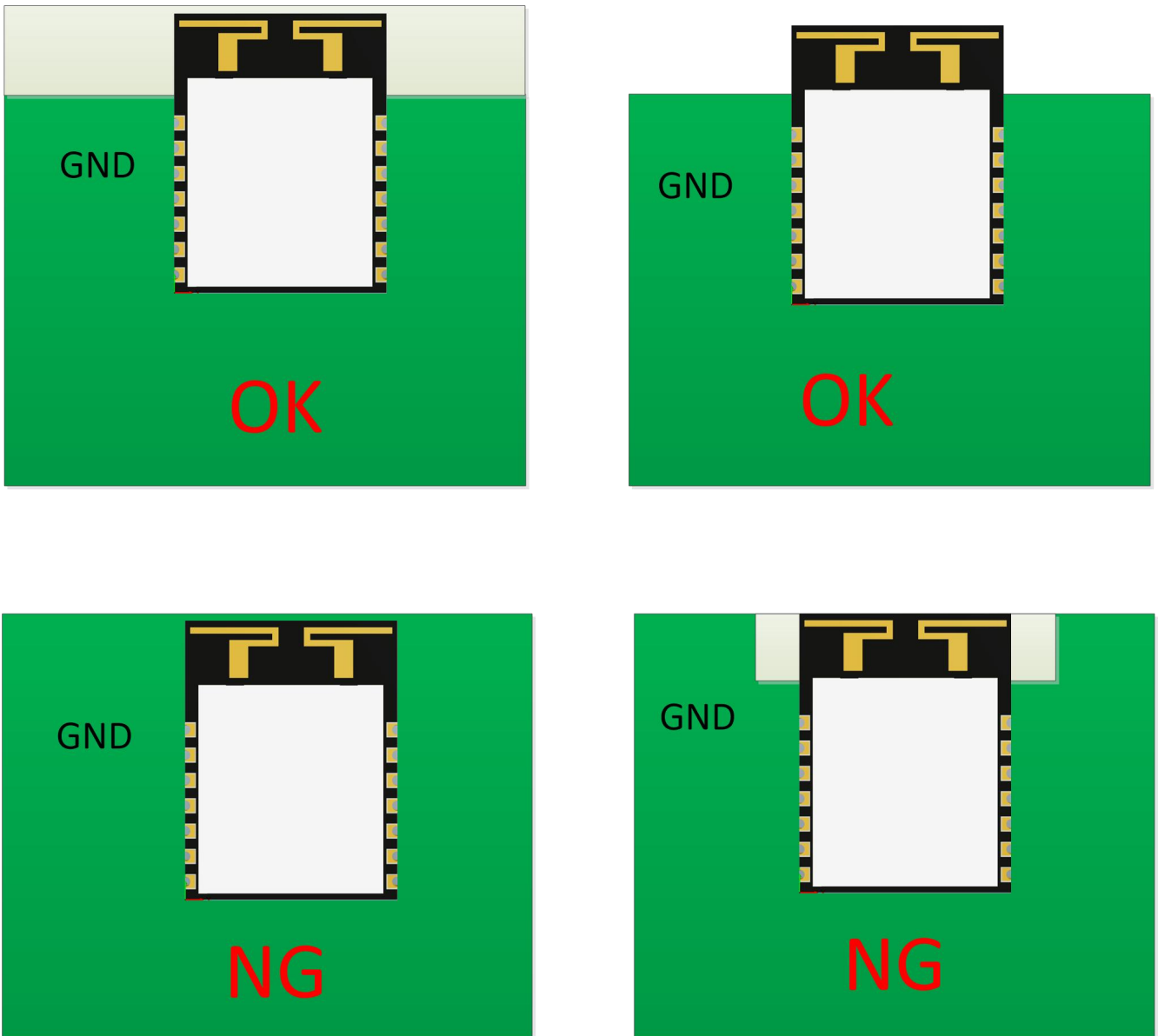

Figure 5-2 Module Placement Layout Suggestions

## 6. Programming Development

A power amplifier (PA) and a low noise amplifier (LNA) have been added to the module. Note that when setting the transmission power of A5133 chip, the maximum cannot exceed 5dBm, otherwise the amplifier inside the module will risk of burning out. Generally, it is sufficient to set the transmission power of A5133 to 0dBm.

The module PA\_EN, LNA\_EN, and CTR pins are the logic control pins of the PA & LNA device inside the module. Please pay attention to their control levels when using them. The control logic is listed as follows:

Mode	PA_EN	LNA_EN	CTR
Launch	1	0	0
Receiving	0	1	1
Dormancy	0	0	0

## 7. reflow soldering curve

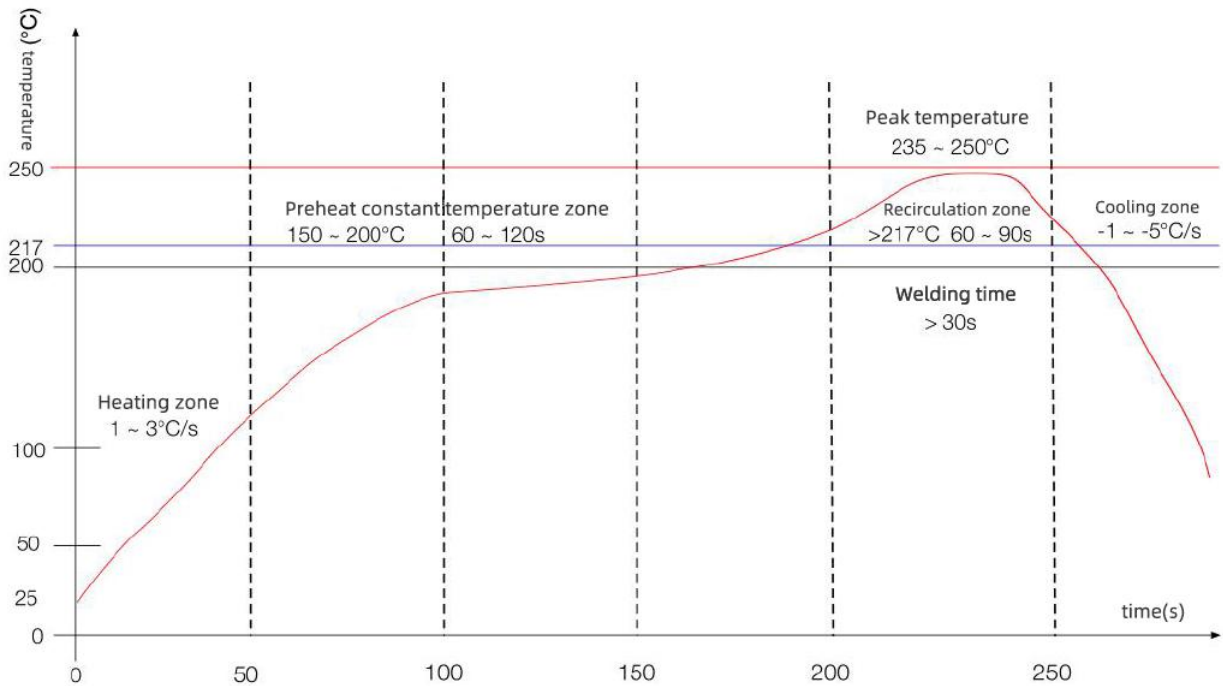

Heating zone-temperature: 25-150°C time: 60-90s Ramp rate: 1-3°C/s  
 Preheat constant temperature zone-temperature: 150-200°C time: 60-120s  
 Reflow soldering area-temperature >217°C time: 60-90s; Peak temperature: 235-250°C time: 30-70s  
 Cooling zone-temperature: Peak temperature -25-150°C Cooling slope -1--5°C/s  
 Solder-tin-silver-copper alloy lead-free solder(SAC305)

## 8. Static Damage Warning

The radio frequency module is a high-voltage electrostatic sensitive device to prevent static electricity from damaging the module.

- 1、Strictly follow anti-static measures, and it is forbidden to touch the module with bare hands during the production process.
- 2、The module should be placed in a placement area that can prevent static electricity.
- 3、The anti-static protection circuit at the high voltage input should be considered in product design.



## 9. Encapsulation information

Mechanical dimensions (unit:mm)

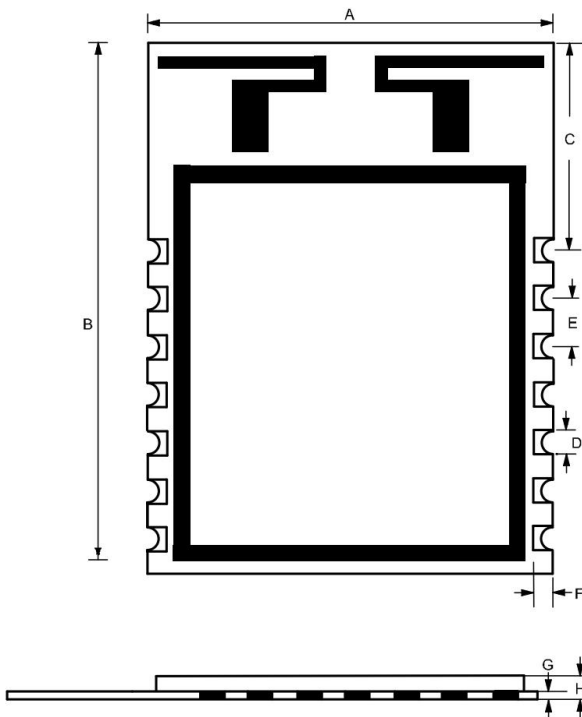

No.	Dimensions (mm)	Error (mm)
A	16.7	± 0.5
B	22.0	± 0.5
C	8.6	± 0.1
D	1.0	± 0.1
E	2.0	± 0.1
F	0.7	± 0.1
G	0.8	± 0.1
H	2.4	± 0.2

## 10. version update

Version	Comment	Date
V1.0	Initial version	May 11, 2022

## 11. Purchase Selection Table

Index	Part Number	Description
1	VG6244S580X0M1	Tape Packaging \Pallet Packaging

## 12. Statement

1. Due to product version upgrade or other reasons, the contents of this document will be updated from time to time. Unless otherwise agreed, this document serves as a guide for use only, and this article

All representations, information and recommendations in do not constitute any express or implied warranty.

2. The Company reserves the final interpretation and modification of all the information provided, subject to change without prior notice.

## 13. Contact Us

**Company:** Shenzhen Wojin Technology Co., Ltd.

**Address:** 205-208, Building C, Zhiyun Valley, No. 1 Sanhe Road,  
Gaofeng Community, Dalang Street, Longhua District, Shenzhen

**Tel:** 0755-23040053

