

## CDCLVP1208 Eight LVPECL Output, High-Performance Clock 2:8 Buffer

### 1 Features

- 2:8 Differential Buffer
- Selectable Clock Inputs Through Control terminal
- Universal Inputs Accept LVPECL, LVDS, and LVCMOS/LVTTL
- Eight LVPECL Outputs
- Maximum Clock Frequency: 2 GHz
- Maximum Core Current Consumption: 73 mA
- Very Low Additive Jitter: <100 fs,rms in 10 kHz to 20 MHz Offset Range:
  - 57 fs, rms (typical) at 122.88 MHz
  - 48 fs, rms (typical) at 156.25 MHz
  - 30 fs, rms (typical) at 312.5 MHz
- 2.375-V to 3.6-V Device Power Supply
- Maximum Propagation Delay: 450 ps
- Maximum Output Skew: 20 ps
- LVPECL Reference Voltage,  $V_{AC\_REF}$ , Available for Capacitive-Coupled Inputs
- Industrial Temperature Range:  $-40^{\circ}\text{C}$  to  $85^{\circ}\text{C}$
- Supports  $105^{\circ}\text{C}$  PCB Temperature (Measured with a Thermal Pad)
- ESD Protection Exceeds 2 kV (HBM)
- Available in 5-mm x 5-mm QFN-28 (RHD) Package

### 2 Applications

- Wireless Communications
- Telecommunications/Networking
- Medical Imaging
- Test and Measurement Equipment

### 3 Description

The CDCLVP1208 is a highly versatile, low additive jitter buffer that can generate eight copies of LVPECL clock outputs from one of two selectable LVPECL, LVDS, or LVCMOS inputs for a variety of communication applications. It has a maximum clock frequency up to 2 GHz. The CDCLVP1208 features an on-chip multiplexer (MUX) for selecting one of two inputs that can be easily configured solely through a control terminal. The overall additive jitter performance is less than 0.1 ps, RMS from 10 kHz to 20 MHz, and overall output skew is as low as 20 ps, making the device a perfect choice for use in demanding applications.

The CDCLVP1208 clock buffer distributes one of two selectable clock inputs (IN0, IN1) to eight pairs of differential LVPECL clock outputs (OUT0, OUT7) with minimum skew for clock distribution. The CDCLVP1208 can accept two clock sources into an input multiplexer. The inputs can be LVPECL, LVDS, or LVCMOS/LVTTL.

The CDCLVP1208 is specifically designed for driving  $50\text{-}\Omega$  transmission lines. When driving the inputs in single-ended mode, the LVPECL bias voltage ( $V_{AC\_REF}$ ) should be applied to the unused negative input terminal. However, for high-speed performance up to 2 GHz, differential mode is strongly recommended.

The CDCLVP1208 is packaged in a small 28-pin, 5-mm x 5-mm QFN package and is characterized for operation from  $-40^{\circ}\text{C}$  to  $85^{\circ}\text{C}$ .

#### Device Information<sup>(1)</sup>

PART NUMBER	PACKAGE	BODY SIZE (NOM)
CDCLVP1208	QFN (28)	5.00 mm x 5.00 mm

(1) For all available packages, see the orderable addendum at the end of the datasheet.

#### Functional Block Diagram

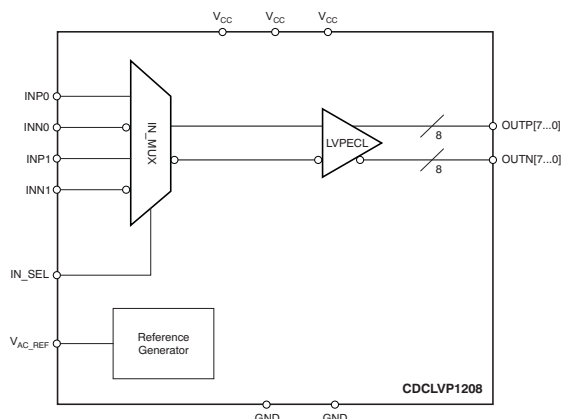

#### Differential Output Peak-to-Peak Voltage vs Frequency

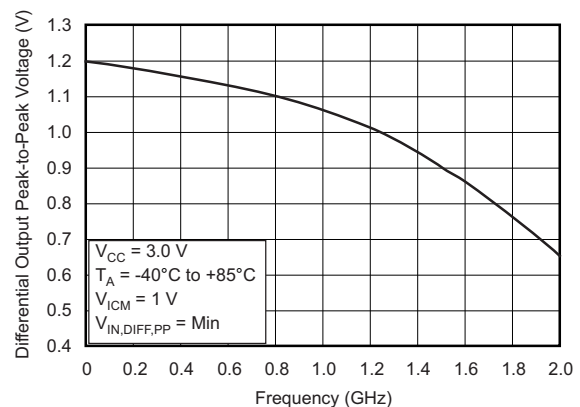

## Table of Contents

<b>1 Features</b> .....	<b>1</b>	8.1 Overview .....	<b>13</b>
<b>2 Applications</b> .....	<b>1</b>	8.2 Functional Block Diagram .....	<b>13</b>
<b>3 Description</b> .....	<b>1</b>	8.3 Feature Description .....	<b>13</b>
<b>4 Revision History</b> .....	<b>2</b>	8.4 Device Functional Modes .....	<b>14</b>
<b>5 Pin Configuration and Functions</b> .....	<b>4</b>	<b>9 Applications and Implementation</b> .....	<b>18</b>
<b>6 Specifications</b> .....	<b>5</b>	9.1 Application Information .....	<b>18</b>
6.1 Absolute Maximum Ratings .....	<b>5</b>	9.2 Typical Application .....	<b>18</b>
6.2 ESD Ratings .....	<b>5</b>	<b>10 Power Supply Recommendations</b> .....	<b>20</b>
6.3 Recommended Operating Conditions .....	<b>5</b>	10.1 Thermal Management .....	<b>20</b>
6.4 Thermal Information .....	<b>5</b>	10.2 Power-Supply Filtering .....	<b>20</b>
6.5 Electrical Characteristics: LVCMOS Input .....	<b>6</b>	<b>11 Layout</b> .....	<b>21</b>
6.6 Electrical Characteristics: Differential Input .....	<b>6</b>	11.1 Layout Guidelines .....	<b>21</b>
6.7 Electrical Characteristics: LVPECL Output, at $V_{CC} = 2.375\text{ V to }2.625\text{ V}$ .....	<b>6</b>	11.2 Layout Example .....	<b>21</b>
6.8 Electrical Characteristics: LVPECL Output, at $V_{CC} = 3\text{ V to }3.6\text{ V}$ .....	<b>8</b>	11.3 Thermal Considerations .....	<b>21</b>
6.9 Pin Characteristics .....	<b>9</b>	<b>12 Device and Documentation Support</b> .....	<b>22</b>
6.10 Timing Requirements .....	<b>9</b>	12.1 Community Resources .....	<b>22</b>
6.11 Typical Characteristics .....	<b>10</b>	12.2 Trademarks .....	<b>22</b>
<b>7 Parameter Measurement Information</b> .....	<b>11</b>	12.3 Electrostatic Discharge Caution .....	<b>22</b>
7.1 Test Configurations .....	<b>11</b>	12.4 Glossary .....	<b>22</b>
<b>8 Detailed Description</b> .....	<b>13</b>	<b>13 Mechanical, Packaging, and Orderable Information</b> .....	<b>22</b>

## 4 Revision History

NOTE: Page numbers for previous revisions may differ from page numbers in the current version.

<b>Changes from Revision D (September 2014) to Revision E</b>	<b>Page</b>
• Added Support for 105°C thermal pad temperature .....	<b>1</b>
• Deleted <i>Device Comparison</i> table; information in POA .....	<b>1</b>
• Changed order of pin descriptions to alphabetical .....	<b>4</b>
• Changed <i>Handing Ratings</i> to <i>ESD Ratings</i> ; moved $T_J$ and storage temperature to <i>Absolute Maximum Ratings</i> .....	<b>5</b>
• Added PCB temperature in <i>Recommended Operating Conditions</i> .....	<b>5</b>
• Added $V_{OH}$ specification for $T_{PCB} \leq 105^\circ\text{C}$ in Electrical Characteristics: LVPECL Output, at $V_{CC} = 2.375\text{ V to }2.625\text{ V}$ .....	<b>6</b>
• Added $V_{OL}$ specification for $T_{PCB} \leq 105^\circ\text{C}$ in Electrical Characteristics: LVPECL Output, at $V_{CC} = 2.375\text{ V to }2.625\text{ V}$ .....	<b>6</b>
• Added $I_{EE}$ specification for $T_{PCB} \leq 105^\circ\text{C}$ in Electrical Characteristics: LVPECL Output, at $V_{CC} = 2.375\text{ V to }2.625\text{ V}$ .....	<b>7</b>
• Added $I_{CC}$ specification for $T_{PCB} \leq 105^\circ\text{C}$ in Electrical Characteristics: LVPECL Output, at $V_{CC} = 2.375\text{ V to }2.625\text{ V}$ .....	<b>7</b>
• Added $V_{OH}$ specification for $T_{PCB} \leq 105^\circ\text{C}$ in Electrical Characteristics: LVPECL Output, at $V_{CC} = 3\text{ V to }3.6\text{ V}$ .....	<b>8</b>
• Added $V_{OL}$ specification for $T_{PCB} \leq 105^\circ\text{C}$ in Electrical Characteristics: LVPECL Output, at $V_{CC} = 3\text{ V to }3.6\text{ V}$ .....	<b>8</b>
• Added $I_{EE}$ specification for $T_{PCB} \leq 105^\circ\text{C}$ in Electrical Characteristics: LVPECL Output, at $V_{CC} = 3\text{ V to }3.6\text{ V}$ .....	<b>8</b>
• Added $I_{CC}$ specification for $T_{PCB} \leq 105^\circ\text{C}$ in Electrical Characteristics: LVPECL Output, at $V_{CC} = 3\text{ V to }3.6\text{ V}$ .....	<b>9</b>
• Added <i>Thermal Considerations</i> section .....	<b>21</b>

<b>Changes from Revision C (June 2014) to Revision D</b>	<b>Page</b>
• Added "NOTE" at the beginning of "Applications and Implementation" section .....	<b>18</b>
• Changed JEDEC symbol to $R_{\theta JA}$ .....	<b>20</b>

**Changes from Revision B (August 2011) to Revision C**
**Page**

• Added data sheet flow and layout to conform with new TI standards. Added the following sections: Application and Implementation; Power Supply Recommendations; Layout; Device and Documentation Support; Mechanical, Packaging, and Ordering Information.....	1
• Added $f_{IN} = 125\text{ MHz}, 312.5\text{ MHz}$ for $V_{OUT, DIFF, PP}$ .....	6
• Added Typical values, Max values, and footnotes for 122.88 MHz, 156.25 MHz, and 312.5 MHz test conditions corresponding to Random Additive Jitter for Electrical Characteristics: LVPECL Output, at $V_{CC} = 2.375\text{ V}$ to $2.625\text{ V}$ .....	7
• Added Typical values, Max values, and footnotes for 122.88 MHz, 156.25 MHz, and 312.5 MHz test conditions corresponding to Random Additive Jitter for Electrical Characteristics: LVPECL Output, at $V_{CC} = 3.0\text{ V}$ to $3.6\text{ V}$ .....	8

**Changes from Revision A (May 2010) to Revision B**
**Page**

• Revised description of pin 7 .....	4
• Corrected $V_{IL}$ parameter description in <i>Electrical Characteristics</i> table for LVCMOS input.....	6
• Added <sup>(1)</sup> footnote (2) to <i>Electrical Characteristics</i> table for LVPECL Output, $V_{CC} = 2.375\text{ V}$ to $2.625\text{ V}$ .....	6
• Changed recommended resistor values in <a href="#">Figure 12(a)</a> .....	14
• Changed recommended resistor values in <a href="#">Figure 16</a> .....	16

(1) Internally generated bias voltage ( $V_{AC\_REF}$ ) is for 3.3 V operation only. It is recommended to apply externally generated bias voltage for  $V_{CC} < 3.0\text{ V}$ .

**Changes from Original (October, 2009) to Revision A**
**Page**

• Changed description of INN1, INN0 and INP1, INP0 pins in <a href="#">Pin Descriptions</a> table .....	4
• Changed descriptions of all output pins in <a href="#">Pin Descriptions</a> table.....	4

## 5 Pin Configuration and Functions

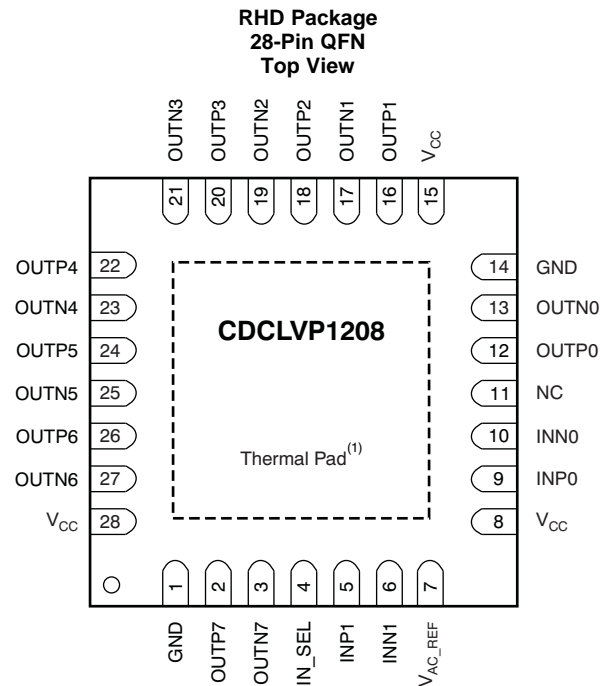

(1) Thermal pad must be soldered to ground.

### Pin Functions

PIN		TYPE	DESCRIPTION
NAME	NUMBER		
GND	1, 14	Ground	Device grounds
INP0, INN0	9, 10	Input	Differential input pair or single-ended input. Unused input pair can be left floating.
INP1, INN1	5, 6	Input	Redundant differential input pair or single-ended input. Unused input pair can be left floating.
IN_SEL	4	Input	Pulldown (see <a href="#">Pin Characteristics</a> ) MUX select input for input choice (see <a href="#">Table 1</a> )
OUTP7, OUTN7	2, 3	Output	Differential LVPECL output pair no. 7. Unused output pair can be left floating.
OUTP6, OUTN6	26, 27	Output	Differential LVPECL output pair no. 6. Unused output pair can be left floating.
OUTP5, OUTN5	24, 25	Output	Differential LVPECL output pair no. 5. Unused output pair can be left floating.
OUTP4, OUTN4	22, 23	Output	Differential LVPECL output pair no. 4. Unused output pair can be left floating.
OUTP3, OUTN3	20, 21	Output	Differential LVPECL output pair no. 3. Unused output pair can be left floating.
OUTP2, OUTN2	18, 19	Output	Differential LVPECL output pair no. 2. Unused output pair can be left floating.
OUTP1, OUTN1	16, 17	Output	Differential LVPECL output pair no. 1. Unused output pair can be left floating.
OUTP0, OUTN0	12, 13	Output	Differential LVPECL output pair no. 0. Unused output pair can be left floating.
V <sub>AC_REF</sub>	7	Output	bias voltage output for capacitive coupled inputs. Do not use V <sub>AC_REF</sub> at V <sub>CC</sub> < 3 V. If used, it is recommended to use a 0.1-μF capacitor to GND on this pin. The output current is limited to 2 mA.
V <sub>CC</sub>	8, 15, 28	Power	2.5-/3.3-V supplies for the device
NC	11	—	Do not connect

**Table 1. Input Selection Table**

IN_SEL	ACTIVE CLOCK INPUT
0	INP0, INN0
1	INP1, INN1

## 6 Specifications

### 6.1 Absolute Maximum Ratings

over operating free-air temperature range (unless otherwise noted) <sup>(1)</sup>

		MIN	MAX	UNIT
V <sub>CC</sub>	Supply voltage <sup>(2)</sup>	-0.5	4.6	V
V <sub>IN</sub>	Input voltage <sup>(3)</sup>	-0.5	V <sub>CC</sub> + 0.5	V
V <sub>OUT</sub>	Output voltage <sup>(3)</sup>	-0.5	V <sub>CC</sub> + 0.5	V
I <sub>IN</sub>	Input current		20	mA
I <sub>OUT</sub>	Output current		50	mA
T <sub>A</sub>	Specified free-air temperature range (no airflow)	-40	85	°C
T <sub>J</sub>	Maximum junction temperature		125	°C
T <sub>stg</sub>	Storage temperature range	-65	150	°C

- (1) Stresses beyond those listed under *Absolute Maximum Ratings* may cause permanent damage to the device. These are stress ratings only, which do not imply functional operation of the device at these or any other conditions beyond those indicated under *Recommended Operating Conditions*. Exposure to absolute-maximum-rated conditions for extended periods may affect device reliability.
- (2) All supply voltages must be supplied simultaneously.
- (3) The input and output negative voltage ratings may be exceeded if the input and output clamp-current ratings are observed.

### 6.2 ESD Ratings

		VALUE	UNIT
V <sub>(ESD)</sub>	Electrostatic discharge Human-body model (HBM), per ANSI/ESDA/JEDEC JS-001 <sup>(1)</sup>	±2000	V

- (1) JEDEC document JEP155 states that 500-V HBM allows safe manufacturing with a standard ESD control process.

### 6.3 Recommended Operating Conditions

over operating free-air temperature range (unless otherwise noted)

		MIN	NOM	MAX	UNIT
V <sub>CC</sub>	Supply voltage	2.375	2.50/3.3	3.60	V
T <sub>A</sub>	Ambient temperature	-40		85	°C
T <sub>PCB</sub>	PCB temperature (measured at thermal pad)			105	°C

### 6.4 Thermal Information

THERMAL METRIC <sup>(1)</sup>		CDCLVP1208	UNIT
		RHD (QFN)	
		28 PINS	
R <sub>θJA</sub>	Junction-to-ambient thermal resistance	39.8, 0 LFM	°C/W
		33.1, 150 LFM	°C/W
		31.4, 400 LFM	°C/W
R <sub>θJC(top)</sub>	Junction-to-case (top) thermal resistance	30	°C/W
R <sub>θJP</sub> <sup>(2)</sup>	Thermal resistance, junction-to-pad	6.12	°C/W
ψ <sub>JT</sub>	Junction-to-top characterization parameter	0.5	°C/W
ψ <sub>JB</sub>	Junction-to-board characterization parameter	11.4	°C/W
R <sub>θJC(bot)</sub>	Junction-to-case (bottom) thermal resistance	6.12	°C/W

- (1) For more information about traditional and new thermal metrics, see the *IC Package Thermal Metrics* application report, [SPRA953](#).
- (2) R<sub>θJP</sub> (junction-to-pad) is used for the QFN package, because the primary heat flow is from the junction to the GND pad of the QFN package.

## 6.5 Electrical Characteristics: LVCMOS Input

 at  $V_{CC} = 2.375\text{ V to }3.6\text{ V}$  and  $T_A = -40^\circ\text{C to }85^\circ\text{C}$  and  $T_{PCB} \leq 105^\circ\text{C}$  (unless otherwise noted)<sup>(1)</sup>

PARAMETER	TEST CONDITIONS	MIN	TYP	MAX	UNIT
$f_{IN}$	Input frequency			200	MHz
$V_{th}$	Input threshold voltage	External threshold voltage applied to complementary input		1.8	V
$V_{IH}$	Input high voltage	$V_{th} + 0.1$		$V_{CC}$	V
$V_{IL}$	Input low voltage	0	$V_{th} - 0.1$		V
$I_{IH}$	Input high current	$V_{CC} = 3.6\text{ V}, V_{IH} = 3.6\text{ V}$		40	$\mu\text{A}$
$I_{IL}$	Input low current	$V_{CC} = 3.6\text{ V}, V_{IL} = 0\text{ V}$		-40	$\mu\text{A}$
$\Delta V/\Delta T$	Input edge rate	20% to 80%		1.5	V/ns
$I_{CAP}$	Input capacitance		5		pF

 (1) [Figure 6](#) and [Figure 7](#) show DC test setup.

## 6.6 Electrical Characteristics: Differential Input

 at  $V_{CC} = 2.375\text{ V to }3.6\text{ V}$  and  $T_A = -40^\circ\text{C to }85^\circ\text{C}$  and  $T_{PCB} \leq 105^\circ\text{C}$  (unless otherwise noted)<sup>(1)</sup>

PARAMETER	TEST CONDITIONS	MIN	TYP	MAX	UNIT
$f_{IN}$	Input frequency			2000	MHz
$V_{IN, DIFF, PP}$	Differential input peak-peak voltage	$f_{IN} \leq 1.5\text{ GHz}$		1.5	V
		$1.5\text{ GHz} \leq f_{IN} \leq 2\text{ GHz}$		1.5	V
$V_{ICM}$	Input common-mode level	1.0		$V_{CC} - 0.3$	V
$I_{IH}$	Input high current	$V_{CC} = 3.6\text{ V}, V_{IH} = 3.6\text{ V}$		40	$\mu\text{A}$
$I_{IL}$	Input low current	$V_{CC} = 3.6\text{ V}, V_{IL} = 0\text{ V}$		-40	$\mu\text{A}$
$\Delta V/\Delta T$	Input edge rate	20% to 80%		1.5	V/ns
$I_{CAP}$	Input capacitance		5		pF

 (1) [Figure 5](#) and [Figure 8](#) show DC test setup. [Figure 9](#) shows AC test setup.

## 6.7 Electrical Characteristics: LVPECL Output, at $V_{CC} = 2.375\text{ V to }2.625\text{ V}$ <sup>(1)</sup>

 at  $T_A = -40^\circ\text{C to }85^\circ\text{C}$  and  $T_{PCB} \leq 105^\circ\text{C}$  (unless otherwise noted)

PARAMETER	TEST CONDITIONS	MIN	TYP	MAX	UNIT
$V_{OH}$	Output high voltage	$T_A \leq 85^\circ\text{C}$		$V_{CC} - 0.9$	V
		$T_{PCB} \leq 105^\circ\text{C}$	$V_{CC} - 1.26$	$V_{CC} - 0.83$	V
$V_{OL}$	Output low voltage	$T_A \leq 85^\circ\text{C}$		$V_{CC} - 1.3$	V
		$T_{PCB} \leq 105^\circ\text{C}$	$V_{CC} - 1.7$	$V_{CC} - 1.25$	V
$V_{OUT, DIFF, PP}$	Differential output peak-peak voltage	$f_{IN} \leq 2\text{ GHz}$		1.35	V
		$f_{IN} = 125\text{ MHz}, 312.5\text{ MHz}$		1.15	
$V_{AC\_REF}$	Input bias voltage	$I_{AC\_REF} = 2\text{ mA}$		$V_{CC} - 1.1$	V
$t_{PD}$	Propagation delay	$V_{IN, DIFF, PP} = 0.1\text{ V}$		450	ps
		$V_{IN, DIFF, PP} = 0.3\text{ V}$		450	ps
$t_{SK, PP}$	Part-to-part skew			125	ps
$t_{SK, O}$	Output skew			20	ps
$t_{SK, P}$	Pulse skew (with 50% duty cycle input)	Crossing-point-to-crossing-point distortion, $f_{OUT} = 100\text{ MHz}$		50	ps

 (1) [Figure 10](#) and [Figure 11](#) show DC and AC test setup.

**Electrical Characteristics: LVPECL Output, at  $V_{CC} = 2.375\text{ V}$  to  $2.625\text{ V}^{(1)}$  (continued)**
 $T_A = -40^\circ\text{C}$  to  $85^\circ\text{C}$  and  $T_{PCB} \leq 105^\circ\text{C}$  (unless otherwise noted)

PARAMETER	TEST CONDITIONS	MIN	TYP	MAX	UNIT	
$t_{RJIT}$	Random additive jitter (with 50% duty cycle input) <sup>(2)</sup>	$f_{OUT} = 100\text{ MHz}$ , $V_{IN,SE} = V_{CC}$ , $V_{th} = 1.25\text{ V}$ , 10 kHz to 20 MHz		0.081		ps, RMS
		$f_{OUT} = 100\text{ MHz}$ , $V_{IN,SE} = 0.9\text{ V}$ , $V_{th} = 1.1\text{ V}$ , 10 kHz to 20 MHz		0.091		ps, RMS
		$f_{OUT} = 2\text{ GHz}$ , $V_{IN,DIFF,PP} = 0.2\text{ V}$ , $V_{ICM} = 1\text{ V}$ , 10 kHz to 20 MHz		0.041		ps, RMS
		$f_{OUT} = 100\text{ MHz}$ , $V_{IN,DIFF,PP} = 0.15\text{ V}$ , $V_{ICM} = 1\text{ V}$ , 10 kHz to 20 MHz		0.088		ps, RMS
		$f_{OUT} = 100\text{ MHz}$ , $V_{IN,DIFF,PP} = 1\text{ V}$ , $V_{ICM} = 1\text{ V}$ , 10 kHz to 20 MHz		0.081		ps, RMS
		$f_{OUT} = 122.88\text{ MHz}$ , <sup>(3)(4)</sup> Square Wave, $V_{IN,PP} = 1\text{ V}$ , 12 kHz to 20 MHz		0.057	0.088	ps, RMS
		$f_{OUT} = 122.88\text{ MHz}$ , <sup>(3)(4)</sup> Square Wave, $V_{IN,PP} = 1\text{ V}$ , 10 kHz to 20 MHz		0.057	0.088	ps, RMS
		$f_{OUT} = 122.88\text{ MHz}$ , <sup>(3)(4)</sup> Square Wave, $V_{IN,PP} = 1\text{ V}$ , 1 kHz to 40 MHz		0.086	0.121	ps, RMS
		$f_{OUT} = 156.25\text{ MHz}$ , <sup>(3)(5)</sup> Square Wave, $V_{IN,PP} = 1\text{ V}$ , 12 kHz to 20 MHz		0.048	0.071	ps, RMS
		$f_{OUT} = 156.25\text{ MHz}$ , <sup>(3)(5)</sup> Square Wave, $V_{IN,PP} = 1\text{ V}$ , 10 kHz to 20 MHz		0.048	0.071	ps, RMS
		$f_{OUT} = 156.25\text{ MHz}$ , <sup>(3)(5)</sup> Square Wave, $V_{IN,PP} = 1\text{ V}$ , 1 kHz to 40 MHz		0.068	0.097	ps, RMS
		$f_{OUT} = 312.5\text{ MHz}$ , <sup>(3)(6)</sup> Square Wave, $V_{IN,PP} = 1\text{ V}$ , 12 kHz to 20 MHz		0.030	0.048	ps, RMS
		$f_{OUT} = 312.5\text{ MHz}$ , <sup>(3)(6)</sup> Square Wave, $V_{IN,PP} = 1\text{ V}$ , 10 kHz to 20 MHz		0.030	0.048	ps, RMS
$f_{OUT} = 312.5\text{ MHz}$ , <sup>(3)(6)</sup> Square Wave, $V_{IN,PP} = 1\text{ V}$ , 1 kHz to 40 MHz		0.045	0.068	ps, RMS		
$t_R/t_F$	Output rise/fall time	20% to 80%		200	ps	
$I_{EE}$	Supply internal current	Outputs unterminated $T_A \leq 85^\circ\text{C}$		73	mA	
		Outputs unterminated, $T_{PCB} \leq 105^\circ\text{C}$		73	mA	
$I_{CC}$	Output and internal supply current	All outputs terminated, 50 $\Omega$ to $V_{CC} - 2$ $T_A \leq 85^\circ\text{C}$		325	mA	
		All outputs terminated, 50 $\Omega$ to $V_{CC} - 2$ $T_{PCB} \leq 105^\circ\text{C}$		355	mA	

(2) Parameter is specified by characterization. Not tested in production.

(3) Input source RMS Jitter ( $t_{RJIT\_IN}$ ) and Total RMS Jitter ( $t_{RJIT\_OUT}$ ) measured using Agilent E5052 Phase Noise Analyzer. Buffer device random additive jitter computed as:  $t_{RJIT} = \text{SQRT}[(t_{RJIT\_OUT})^2 - (t_{RJIT\_IN})^2]$ .

(4) Input source: 122.88-MHz Rohde & Schwarz SMA100A Signal Generator.

(5) Input source: 156.25-MHz Rohde & Schwarz SMA100A Signal Generator.

(6) Input source: 312.5-MHz Rohde & Schwarz SMA100A Signal Generator.

**6.8 Electrical Characteristics: LVPECL Output, at  $V_{CC} = 3\text{ V to }3.6\text{ V}^{(1)}$** 
 $T_A = -40^\circ\text{C to }85^\circ\text{C}$  and  $T_{PCB} \leq 105^\circ\text{C}$  (unless otherwise noted)

PARAMETER	TEST CONDITIONS	MIN	TYP	MAX	UNIT
$V_{OH}$ Output high voltage	$T_A \leq 85^\circ\text{C}$	$V_{CC} - 1.26$		$V_{CC} - 0.9$	V
	$T_{PCB} \leq 105^\circ\text{C}$	$V_{CC} - 1.26$		$V_{CC} - 0.85$	V
$V_{OL}$ Output low voltage	$T_A \leq 85^\circ\text{C}$	$V_{CC} - 1.7$		$V_{CC} - 1.3$	V
	$T_{PCB} \leq 105^\circ\text{C}$	$V_{CC} - 1.7$		$V_{CC} - 1.3$	V
$V_{OUT, DIFF, PP}$ Differential output peak-peak voltage	$f_{IN} \leq 2\text{ GHz}$	0.65		1.35	V
$V_{AC, REF}$ Input bias voltage	$I_{AC, REF} = 2\text{ mA}$	$V_{CC} - 1.6$		$V_{CC} - 1.1$	V
$t_{PD}$ Propagation delay	$V_{IN, DIFF, PP} = 0.1\text{ V}$			450	ps
	$V_{IN, DIFF, PP} = 0.3\text{ V}$			450	ps
$t_{SK, PP}$ Part-to-part skew				125	ps
$t_{SK, O}$ Output skew				20	ps
$t_{SK, P}$ Pulse skew (with 50% duty cycle input)	Crossing-point-to-crossing-point distortion, $f_{OUT} = 100\text{ MHz}$	-50		50	ps
$t_{RJIT}$ Random additive jitter, (with 50% duty cycle input) <sup>(2)</sup>	$f_{OUT} = 100\text{ MHz}$ , $V_{IN, SE} = V_{CC}$ , $V_{th} = 1.65\text{ V}$ , 10 kHz to 20 MHz		0.101		ps, RMS
	$f_{OUT} = 100\text{ MHz}$ , $V_{IN, SE} = 0.9\text{ V}$ , $V_{th} = 1.1\text{ V}$ , 10 kHz to 20 MHz		0.13		ps, RMS
	$f_{OUT} = 2\text{ GHz}$ , $V_{IN, DIFF, PP} = 0.2\text{ V}$ , $V_{ICM} = 1\text{ V}$ , 10 kHz to 20 MHz		0.069		ps, RMS
	$f_{OUT} = 100\text{ MHz}$ , $V_{IN, DIFF, PP} = 0.15\text{ V}$ , $V_{ICM} = 1\text{ V}$ , 10 kHz to 20 MHz		0.094		ps, RMS
	$f_{OUT} = 100\text{ MHz}$ , $V_{IN, DIFF, PP} = 1\text{ V}$ , $V_{ICM} = 1\text{ V}$ , 10 kHz to 20 MHz		0.094		ps, RMS
	$f_{OUT} = 122.88\text{ MHz}$ , <sup>(3)(4)</sup> Square Wave, $V_{IN, PP} = 1\text{ V}$ , 12 kHz to 20 MHz		0.057		ps, RMS
	$f_{OUT} = 122.88\text{ MHz}$ , <sup>(3)(4)</sup> Square Wave, $V_{IN, PP} = 1\text{ V}$ , 10 kHz to 20 MHz		0.057		ps, RMS
	$f_{OUT} = 122.88\text{ MHz}$ , <sup>(3)(4)</sup> Square Wave, $V_{IN, PP} = 1\text{ V}$ , 1 kHz to 40 MHz		0.086		ps, RMS
	$f_{OUT} = 156.25\text{ MHz}$ , <sup>(4)(5)</sup> Square Wave, $V_{IN, PP} = 1\text{ V}$ , 12 kHz to 20 MHz		0.048		ps, RMS
	$f_{OUT} = 156.25\text{ MHz}$ , <sup>(4)(5)</sup> Square Wave, $V_{IN, PP} = 1\text{ V}$ , 10 kHz to 20 MHz		0.048		ps, RMS
	$f_{OUT} = 156.25\text{ MHz}$ , <sup>(4)(5)</sup> Square Wave, $V_{IN, PP} = 1\text{ V}$ , 1 kHz to 40 MHz		0.068		ps, RMS
	$f_{OUT} = 312.5\text{ MHz}$ , <sup>(4)(6)</sup> Square Wave, $V_{IN, PP} = 1\text{ V}$ , 12 kHz to 20 MHz		0.030		ps, RMS
	$f_{OUT} = 312.5\text{ MHz}$ , <sup>(4)(6)</sup> Square Wave, $V_{IN, PP} = 1\text{ V}$ , 10 kHz to 20 MHz		0.030		ps, RMS
$f_{OUT} = 312.5\text{ MHz}$ , <sup>(4)(6)</sup> Square Wave, $V_{IN, PP} = 1\text{ V}$ , 1 kHz to 40 MHz		0.045		ps, RMS	
$t_R/t_F$ Output rise/fall time	20% to 80%			200	ps
$I_{EE}$ Supply internal current	Outputs unterminated, $T_A \leq 85^\circ\text{C}$			73	mA
	Outputs unterminated, $T_{PCB} \leq 105^\circ\text{C}$			73	mA

(1) Figure 10 and Figure 11 show DC and AC test setup.

(2) Parameter is specified by characterization. Not tested in production.

(3) Input source: 122.88-MHz Rohde & Schwarz SMA100A Signal Generator.

(4) Input source RMS Jitter ( $t_{RJIT, IN}$ ) and Total RMS Jitter ( $t_{RJIT, OUT}$ ) measured using Agilent E5052 Phase Noise Analyzer. Buffer device random additive jitter computed as:  $t_{RJIT} = \text{SQRT}[(t_{RJIT, OUT})^2 - (t_{RJIT, IN})^2]$ .

(5) Input source: 156.25-MHz Rohde & Schwarz SMA100A Signal Generator.

(6) Input source: 312.5-MHz Rohde & Schwarz SMA100A Signal Generator.

**Electrical Characteristics: LVPECL Output, at  $V_{CC} = 3\text{ V to }3.6\text{ V}^{(1)}$  (continued)**

$T_A = -40^\circ\text{C to }85^\circ\text{C}$  and  $T_{PCB} \leq 105^\circ\text{C}$  (unless otherwise noted)

PARAMETER	TEST CONDITIONS	MIN	TYP	MAX	UNIT
$I_{CC}$	Output and internal supply current			325	mA
	All outputs terminated, 50 $\Omega$ to $V_{CC} - 2$ $T_A \leq 85^\circ\text{C}$			355	mA
	All outputs terminated, 50 $\Omega$ to $V_{CC} - 2$ $T_{PCB} \leq 105^\circ\text{C}$				

**6.9 Pin Characteristics**

PARAMETER	MIN	TYP	MAX	UNIT
$R_{PULLDOWN}$ Input pulldown resistor		150		k $\Omega$

**6.10 Timing Requirements**

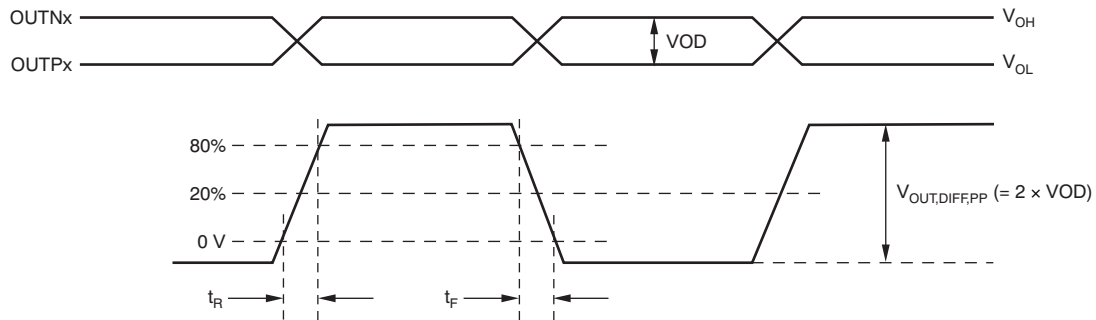

**Figure 1. Output Voltage and Rise/Fall Time**

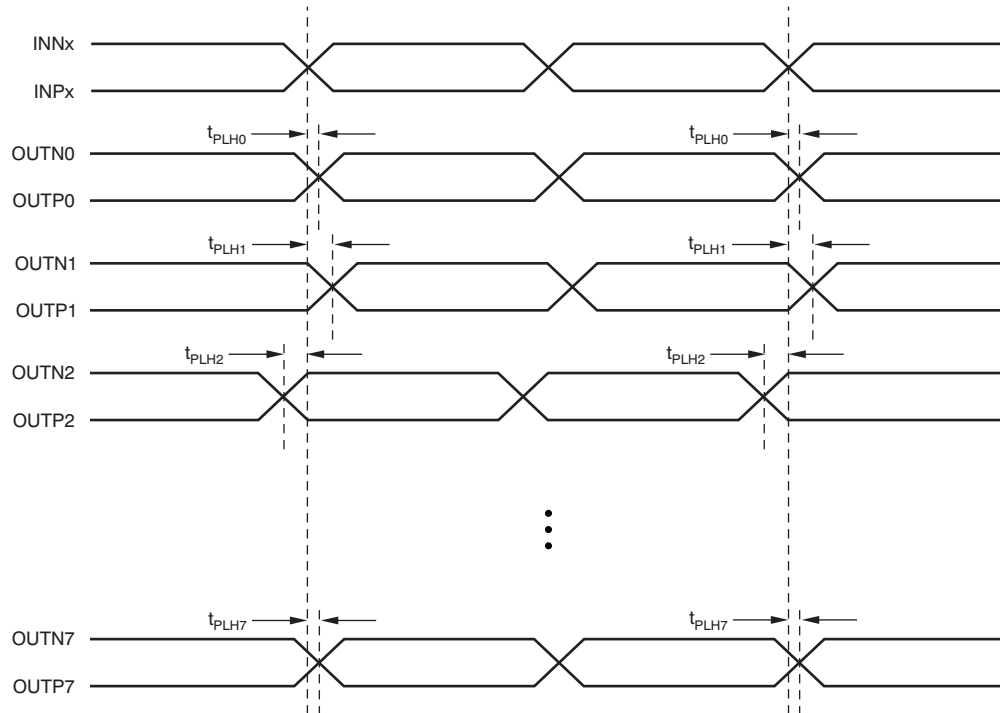

- (1) Output skew is calculated as the greater of the following: As the difference between the fastest and the slowest t<sub>PLH<sub>n</sub></sub> (n = 0, 1, 2....7), or as the difference between the fastest and the slowest t<sub>PHL<sub>n</sub></sub> (n = 0, 1, 2....7).
- (2) Part-to-part skew is calculated as the greater of the following: As the difference between the fastest and the slowest t<sub>PLH<sub>n</sub></sub> (n = 0, 1, 2....7) across multiple devices, or the difference between the fastest and the slowest t<sub>PHL<sub>n</sub></sub> (n = 0, 1, 2....7) across multiple devices.

Figure 2. Output and Part-to-Part Skew

### 6.11 Typical Characteristics

at T<sub>A</sub> = -40°C to +85°C (unless otherwise noted)

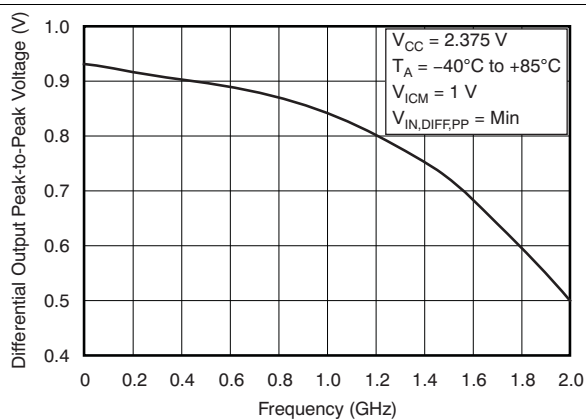

Figure 3. Differential Output Peak-to-Peak Voltage Vs Frequency

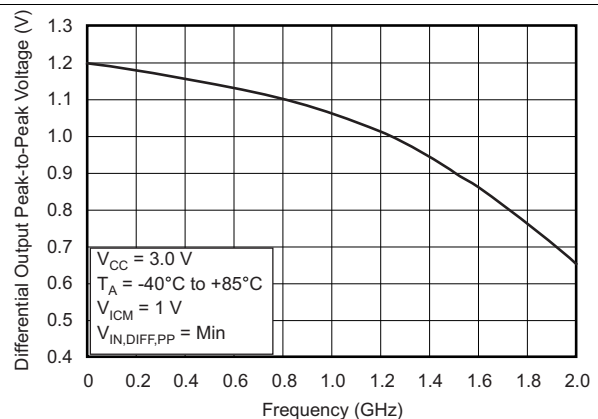

Figure 4. Differential Output Peak-to-Peak Voltage Vs Frequency

## 7 Parameter Measurement Information

### 7.1 Test Configurations

Figure 5 through Figure 11 illustrate how the device should be set up for a variety of test configurations.

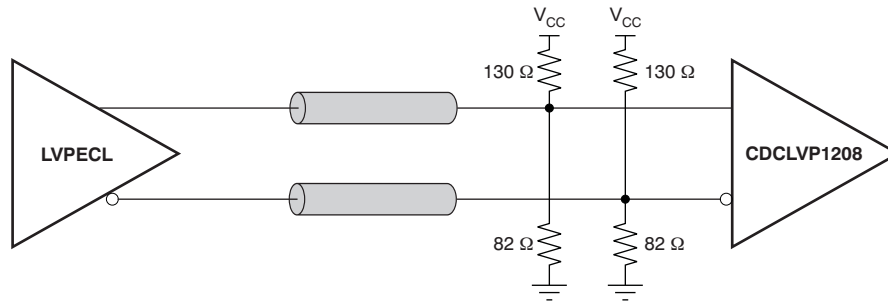

Figure 5. DC-Coupled LVPECL Input During Device Test

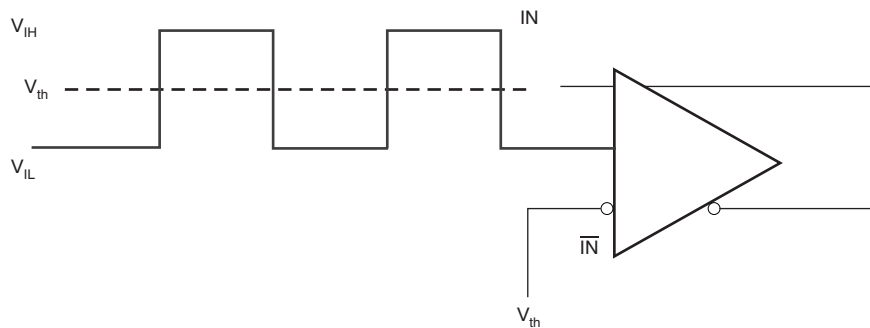

Figure 6. DC-Coupled LVCMOS Input During Device Test

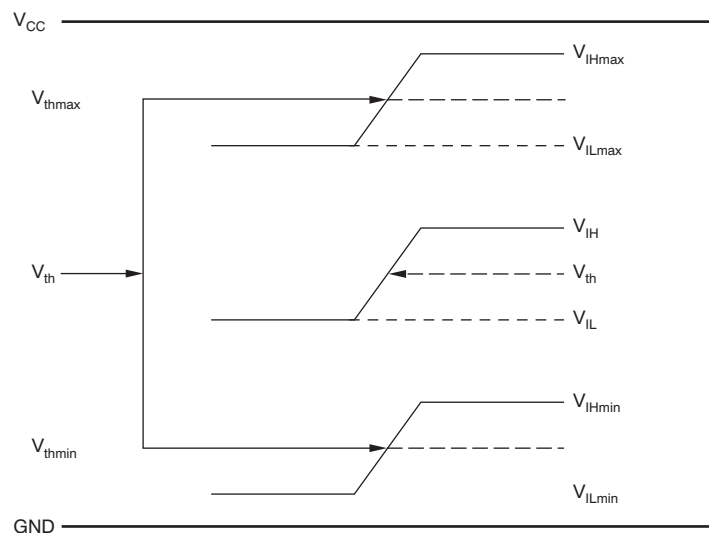
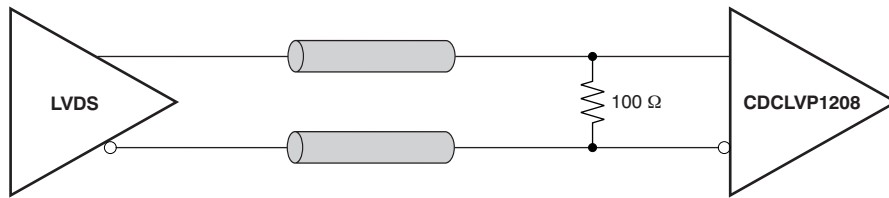
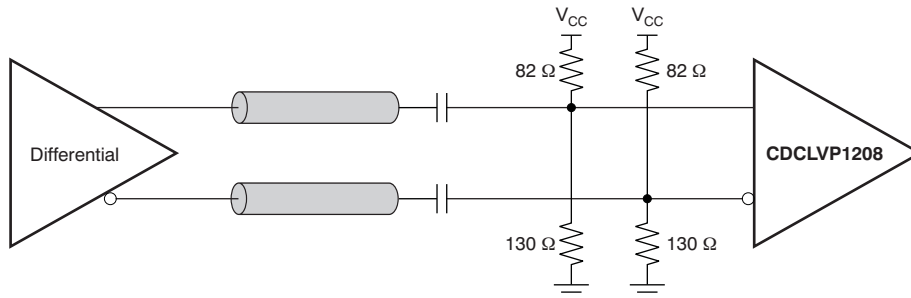
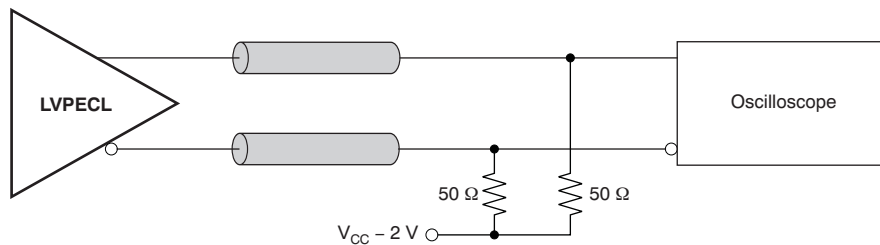
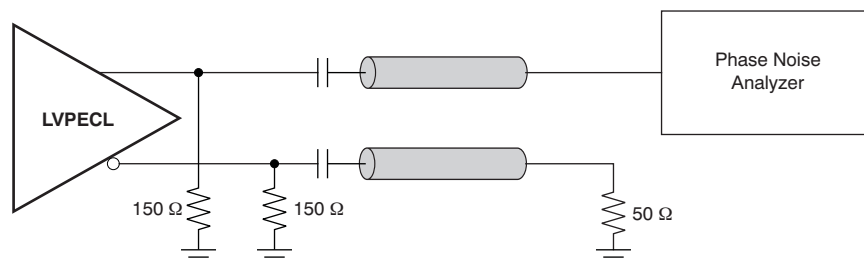

Figure 7.  $V_{th}$  Variation over LVCMOS  $V_{th}$  Levels

**Test Configurations (continued)**

**Figure 8. DC-Coupled LVDS Input During Device Test**

**Figure 9. AC-Coupled Differential Input to Device**

**Figure 10. LVPECL Output DC Configuration During Device Test**

**Figure 11. LVPECL Output AC Configuration During Device Test**

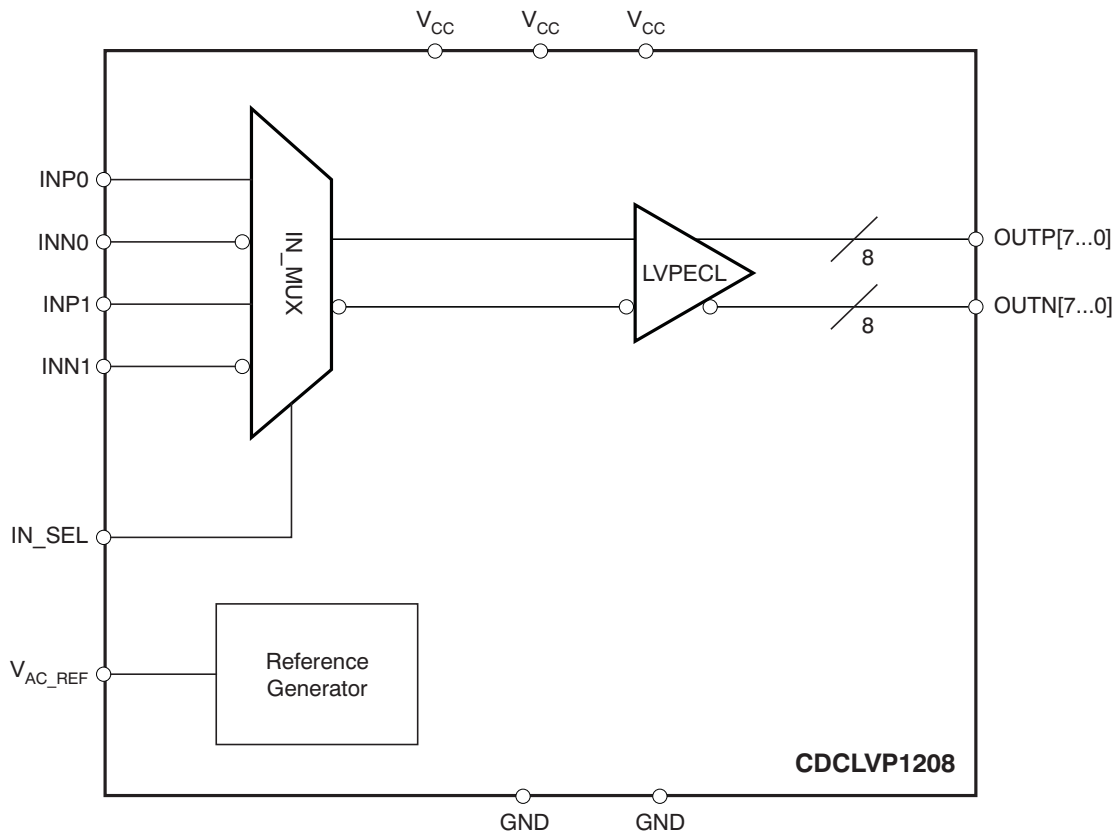
## 8 Detailed Description

### 8.1 Overview

The CDCLVP1208 is an open emitter for LVPECL outputs. Therefore, proper biasing and termination are required to ensure correct operation of the device and to minimize signal integrity. The proper termination for LVPECL outputs is a  $50\ \Omega$  to  $(V_{CC} - 2)\text{ V}$ , but this DC voltage is not readily available on PCB. Therefore, a Thevenin equivalent circuit is worked out for the LVPECL termination in both direct-coupled (DC) and AC-coupled configurations. These configurations are shown in Figure 12 (a and b) for  $V_{CC} = 2.5\text{ V}$  and Figure 13 (a and b) for  $V_{CC} = 3.3\text{ V}$ , respectively. It is recommended to place all resistive components close to either the driver end or the receiver end. If the supply voltage for the driver and receiver is different, AC coupling is required.

### 8.2 Functional Block Diagram



### 8.3 Feature Description

The CDCLVP1208 is a low additive jitter universal to LVPECL fan out buffer with 2 selectable inputs. The small package, low output skew, and low additive jitter make for a flexible device in demanding applications.

## 8.4 Device Functional Modes

The two inputs of the CDCLVP1208 are internally muxed together and can be selected via the control pin. Unused inputs and outputs can be left floating to reduce overall component cost. Both AC and DC coupling schemes can be used with the CDCLVP1208 to provide greater system flexibility.

### 8.4.1 LVPECL Output Termination

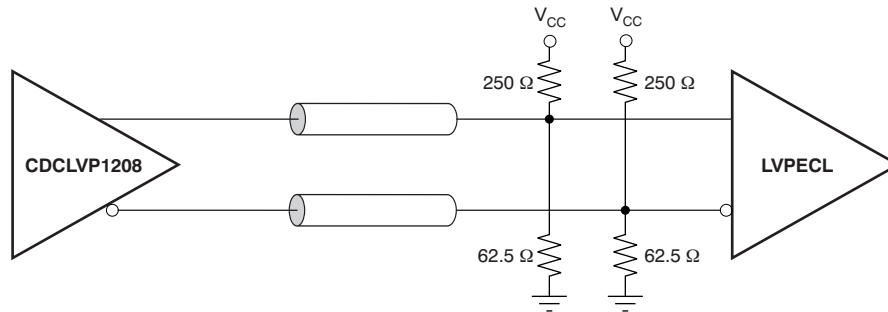

(a) Output DC Termination

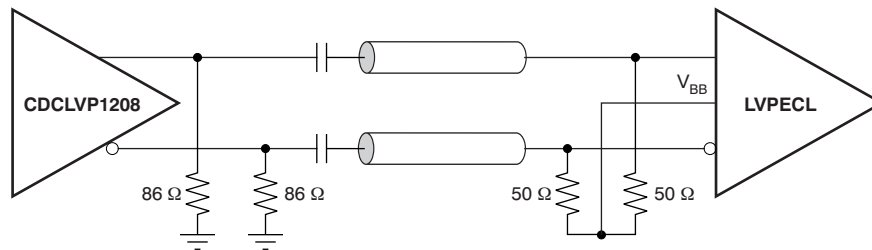

(b) Output AC Termination

**Figure 12. LVPECL Output DC and AC Termination for  $V_{CC} = 2.5\text{ V}$**

Device Functional Modes (continued)

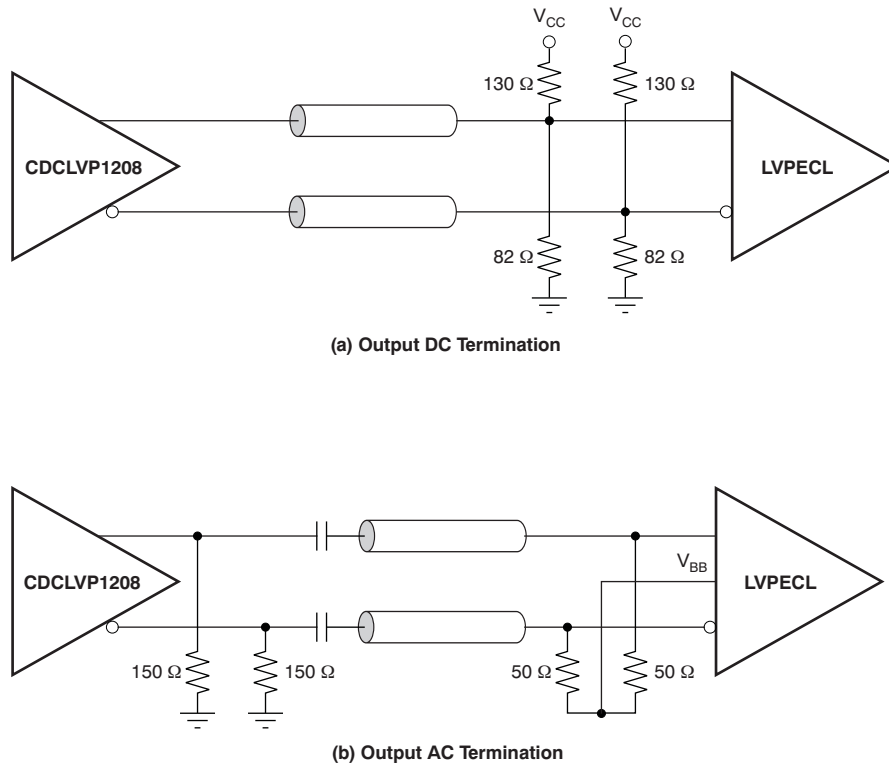

Figure 13. LVPECL Output DC and AC Termination for  $V_{CC} = 3.3\text{ V}$

8.4.2 Input Termination

The CDCLVP1208 inputs can be interfaced with LVPECL, LVDS, or LVCMOS drivers. Figure 14 illustrates how to dc couple an LVCMOS input to the CDCLVP1208. The series resistance ( $R_S$ ) should be placed close to the LVCMOS driver; its value is calculated as the difference between the transmission line impedance and the driver output impedance.

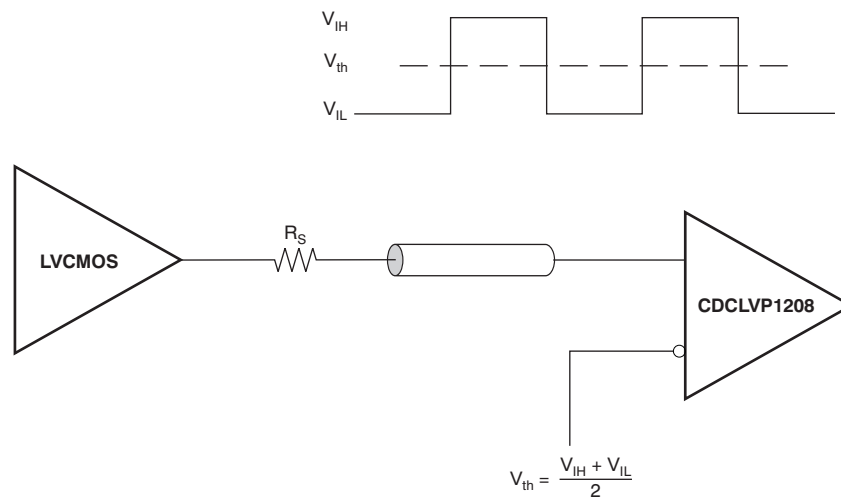
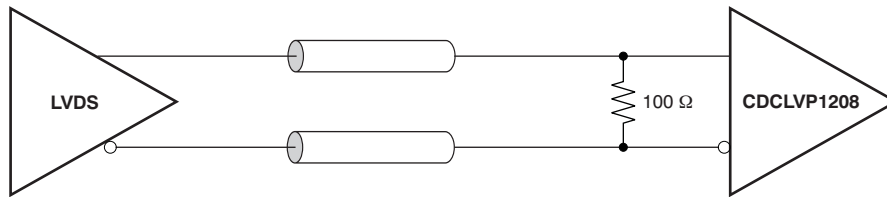

Figure 14. DC-Coupled LVCMOS Input to CDCLVP1208

**Device Functional Modes (continued)**

Figure 15 shows how to DC couple LVDS inputs to the CDCLVP1208. Figure 16 and Figure 17 describe the method of DC coupling LVPECL inputs to the CDCLVP1208 for  $V_{CC} = 2.5\text{ V}$  and  $V_{CC} = 3.3\text{ V}$ , respectively.



**Figure 15. DC-Coupled LVDS Inputs to CDCLVP1208**

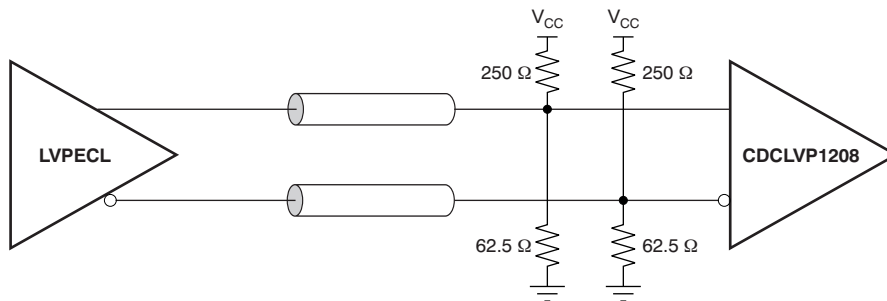

**Figure 16. DC-Coupled LVPECL Inputs to CDCLVP1208 ( $V_{CC} = 2.5\text{ V}$ )**

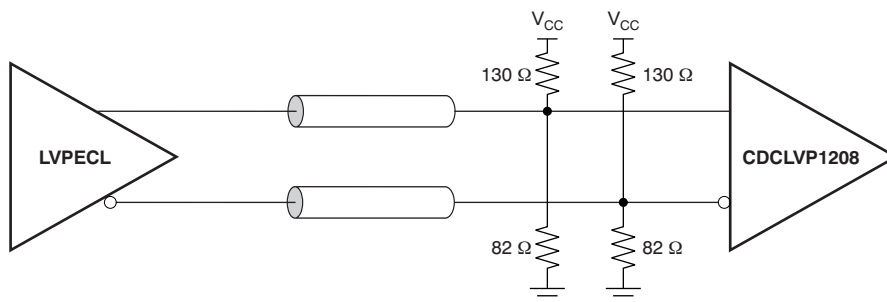

**Figure 17. DC-Coupled LVPECL Inputs to CDCLVP1208 ( $V_{CC} = 3.3\text{ V}$ )**

**Device Functional Modes (continued)**

Figure 18 and Figure 19 show the technique of AC coupling differential inputs to the CDCLVP1208 for  $V_{CC} = 2.5$  V and  $V_{CC} = 3.3$  V, respectively. It is recommended to place all resistive components close to either the driver end or the receiver end. If the supply voltages of the driver and receiver are different, AC coupling is required.

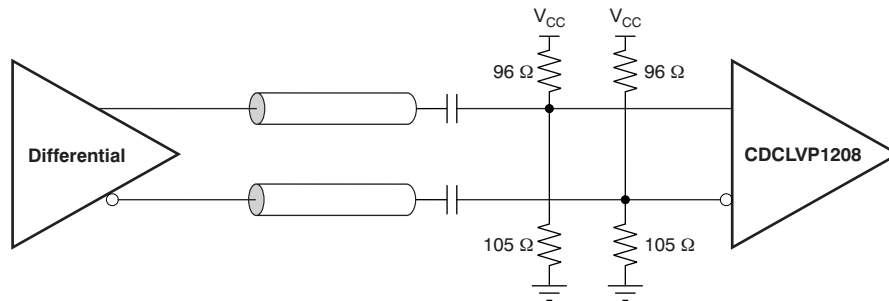

**Figure 18. AC-Coupled Differential Inputs to CDCLVP1208 ( $V_{CC} = 2.5$  V)**

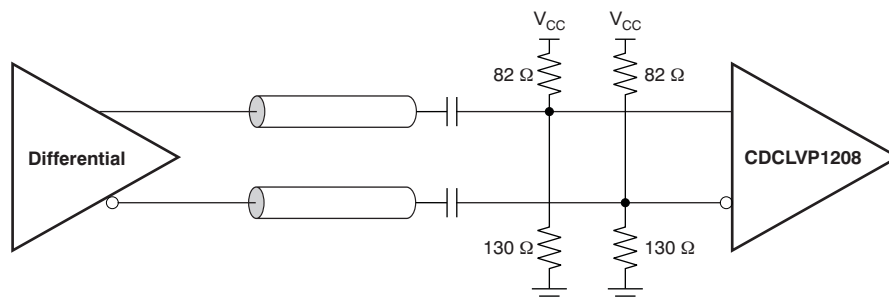

**Figure 19. AC-Coupled Differential Inputs to CDCLVP1208 ( $V_{CC} = 3.3$  V)**

## 9 Applications and Implementation

### NOTE

Information in the following applications sections is not part of the TI component specification, and TI does not warrant its accuracy or completeness. TI's customers are responsible for determining suitability of components for their purposes. Customers should validate and test their design implementation to confirm system functionality.

### 9.1 Application Information

The CDCLVP1208 is a low additive jitter LVPECL fanout buffer that can generate four copies of two selectable LVPECL, LVDS, or LVC MOS inputs. The CDCLVP1208 can accept reference clock frequencies up to 2 GHz while providing low output skew.

### 9.2 Typical Application

#### 9.2.1 Fanout Buffer for Line Card Application

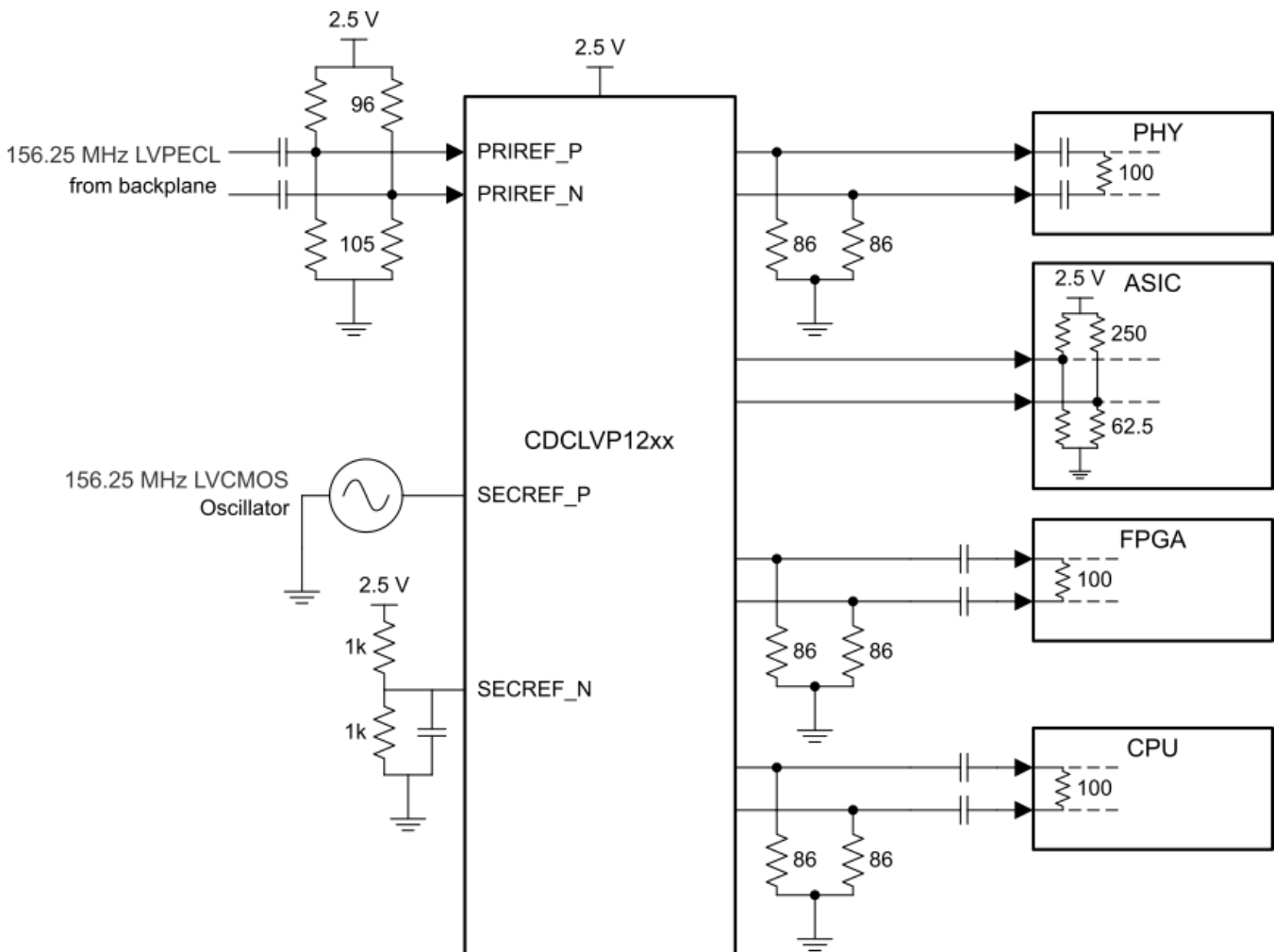

**Figure 20. CDCLVP1208 Block Diagram**

## Typical Application (continued)

### 9.2.2 Design Requirements

The CDCLVP1208 shown in Figure 20 is configured to be able to select two inputs, a 156.25-MHz LVPECL clock from the backplane, or a secondary 156.25 MHz LVCMOS 2.5V oscillator. Either signal can be then fanned out to desired devices, as shown.

The configuration example is driving 4 LVPECL receivers in a line-card application with the following properties:

- The PHY device has internal AC coupling and appropriate termination and biasing. The CDCLVP1208 will need to be provided with 86-Ω emitter resistors near the driver for proper operation.
- The ASIC is capable of DC coupling with a 2.5-V LVPECL driver such as the CDCLVP1208. This ASIC features internal termination so no additional components are needed.
- The FPGA requires external AC coupling but has internal termination. Again, 86-Ω emitter resistors are placed near the CDCLVP1208, and 0.1-μF capacitors are placed to provide AC coupling. Similarly, the CPU is internally terminated and requires external AC-coupling capacitors.

### 9.2.3 Detailed Design Procedure

Refer to [Input Termination](#) for proper input terminations, dependent on single ended or differential inputs.

Refer to [LVPECL Output Termination](#) for output termination schemes depending on the receiver application.

Unused outputs can be left floating.

In this example, the PHY, ASIC, and FPGA/CPU require different schemes. Power supply filtering and bypassing is critical for low noise applications.

See [Power Supply Recommendations](#) for recommended filtering techniques. A reference layout is provided on the CDCLVP1208 Evaluation Module at [SCAU038](#).

#### 9.2.3.1 Application Curves

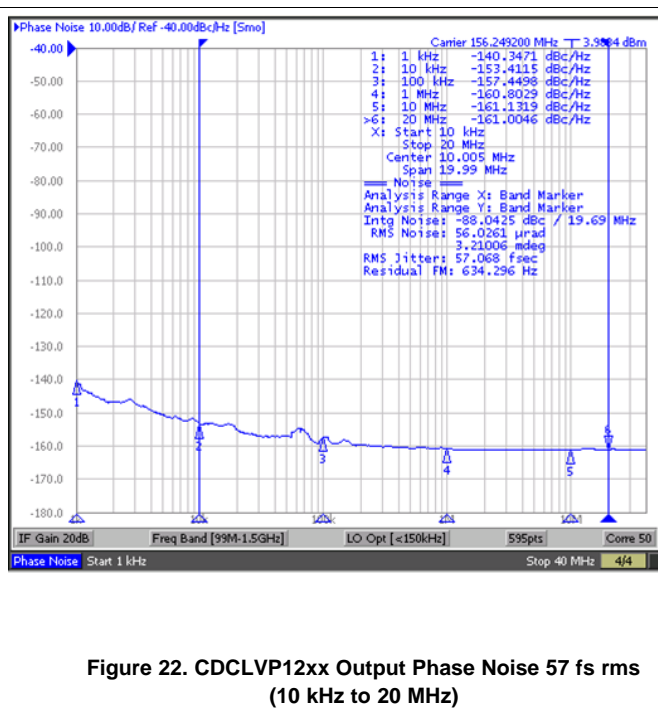
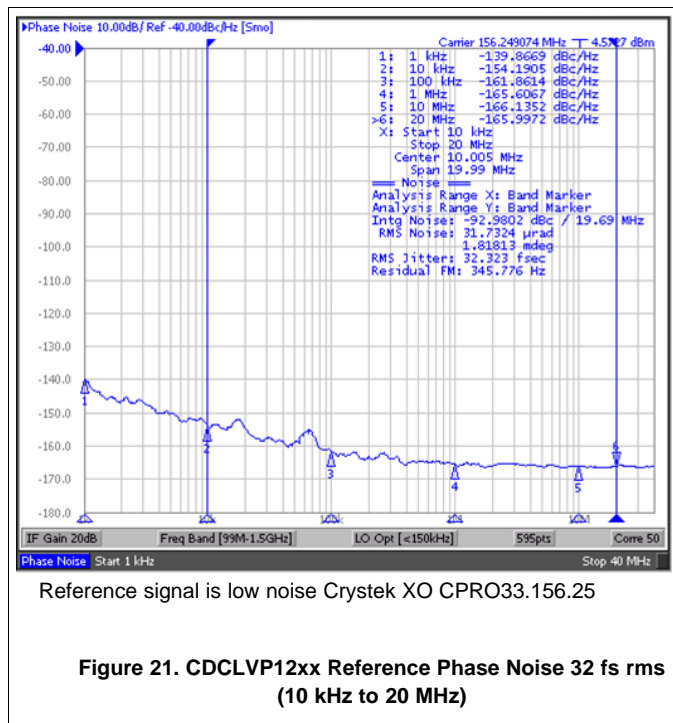

The low additive noise of the CDCLVP12xx can be shown in this line-card application. The low noise 156.25-MHz XO with 32-fs RMS jitter drives the CDCLVP12xx, resulting in 57-fs RMS when integrated from 10 kHz to 20 MHz. The resultant additive jitter is a low 47-fs RMS for this configuration.

## 10 Power Supply Recommendations

### 10.1 Thermal Management

Power consumption of the CDCLVP1208 can be high enough to require attention to thermal management. For reliability and performance reasons, the die temperature should be limited to a maximum of 125°C. That is, as an estimate, ambient temperature ( $T_A$ ) plus device power consumption times  $R_{\theta JA}$  should not exceed 125°C.

The device package has an exposed pad that provides the primary heat removal path to the printed circuit board (PCB). To maximize the heat dissipation from the package, a thermal landing pattern including multiple vias to a ground plane must be incorporated into the PCB within the footprint of the package. The exposed pad must be soldered down to ensure adequate heat conduction out of the package. [Figure 24](#) shows a recommended land and via pattern.

### 10.2 Power-Supply Filtering

High-performance clock buffers are sensitive to noise on the power supply, which can dramatically increase the additive jitter of the buffer. Thus, it is essential to reduce noise from the system power supply, especially when jitter/phase noise is very critical to applications.

Filter capacitors are used to eliminate the low-frequency noise from the power supply, where the bypass capacitors provide the very low impedance path for high-frequency noise and guard the power-supply system against the induced fluctuations. These bypass capacitors also provide instantaneous current surges as required by the device and should have low equivalent series resistance (ESR). To properly use the bypass capacitors, they must be placed very close to the power-supply terminals and laid out with short loops to minimize inductance. It is recommended to add as many high-frequency (for example, 0.1- $\mu\text{F}$ ) bypass capacitors as there are supply terminals in the package. It is recommended, but not required, to insert a ferrite bead between the board power supply and the chip power supply that isolates the high-frequency switching noises generated by the clock driver; these beads prevent the switching noise from leaking into the board supply. It is imperative to choose an appropriate ferrite bead with very low DC resistance in order to provide adequate isolation between the board supply and the chip supply, as well as to maintain a voltage at the supply terminals that is greater than the minimum voltage required for proper operation.

[Figure 23](#) illustrates this recommended power-supply decoupling method.

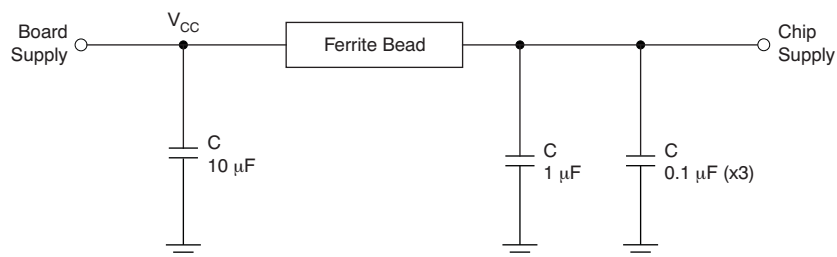

**Figure 23. Power-Supply Decoupling**

## 11 Layout

### 11.1 Layout Guidelines

Power consumption of the CDCLVP1208 can be high enough to require attention to thermal management. For reliability and performance reasons, the die temperature should be limited to a maximum of 125°C. That is, as an estimate, ambient temperature (TA) plus device power consumption times  $R_{\theta JA}$  should not exceed 125°C.

The device package has an exposed pad that provides the primary heat removal path to the printed circuit board (PCB). To maximize the heat dissipation from the package, a thermal landing pattern including multiple vias to a ground plane must be incorporated into the PCB within the footprint of the package. The exposed pad must be soldered down to ensure adequate heat conduction out of the package. [Figure 24](#) shows a recommended land and via pattern.

### 11.2 Layout Example

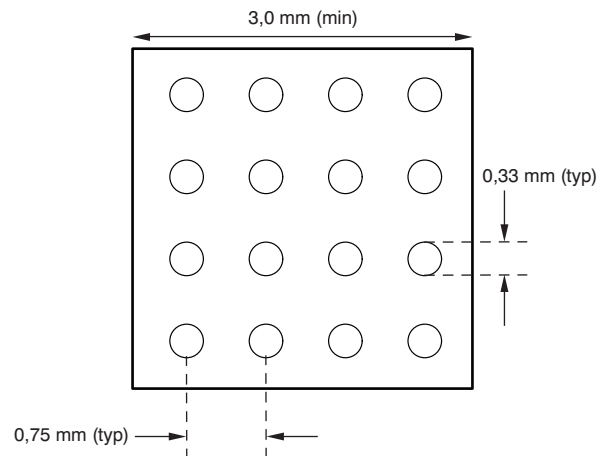

Figure 24. Recommended PCB Layout

### 11.3 Thermal Considerations

The CDCLVP1208 supports high temperatures on the printed circuit board (PCB) measured at the thermal pad. The system designer needs to ensure that the maximum junction temperature is not exceeded.  $\Psi_{jb}$  can allow the system designer to measure the board temperature with a fine gauge thermocouple and back calculate the junction temperature using [Equation 1](#). Note that  $\Psi_{jb}$  is close to  $R_{\theta JB}$  as 75% to 95% of the heat of a device is dissipated by the PCB. For further information, refer to [SPRA953](#) and [SLUA566](#).

$$T_{\text{junction}} = T_{\text{PCB}} + (\Psi_{jb} \times \text{Power}) \quad (1)$$

#### Example:

Calculation of the junction-lead temperature with a 4-layer JEDEC test board using four thermal vias:

$$T_{\text{PCB}} = 105^{\circ}\text{C}$$

$$\Psi_{jb} = 11.4^{\circ}\text{C/W}$$

$$\text{Power}_{\text{inclTerm}} = I_{\text{max}} \times V_{\text{max}} = 355 \text{ mA} \times 3.6 \text{ V} = 1278 \text{ mW (max power consumption including termination resistors)}$$

$$\text{Power}_{\text{exclTerm}} = 976 \text{ mW (max power consumption excluding termination resistors, see SLYT127 for further details)}$$

$$\Delta T_{\text{Junction}} = \Psi_{jb} \times \text{Power}_{\text{exclTerm}} = 11.4^{\circ}\text{C/W} \times 976 \text{ mW} = 11.13^{\circ}\text{C}$$

$$T_{\text{Junction}} = \Delta T_{\text{Junction}} + T_{\text{Chassis}} = 11.13^{\circ}\text{C} + 105^{\circ}\text{C} = 116.13^{\circ}\text{C (the maximum junction temperature of } 125^{\circ}\text{C is not violated)}$$

## 12 Device and Documentation Support

### 12.1 Community Resources

The following links connect to TI community resources. Linked contents are provided "AS IS" by the respective contributors. They do not constitute TI specifications and do not necessarily reflect TI's views; see TI's [Terms of Use](#).

**TI E2E™ Online Community** *TI's Engineer-to-Engineer (E2E) Community*. Created to foster collaboration among engineers. At [e2e.ti.com](http://e2e.ti.com), you can ask questions, share knowledge, explore ideas and help solve problems with fellow engineers.

**Design Support** *TI's Design Support* Quickly find helpful E2E forums along with design support tools and contact information for technical support.

### 12.2 Trademarks

E2E is a trademark of Texas Instruments.  
All other trademarks are the property of their respective owners.

### 12.3 Electrostatic Discharge Caution



These devices have limited built-in ESD protection. The leads should be shorted together or the device placed in conductive foam during storage or handling to prevent electrostatic damage to the MOS gates.

### 12.4 Glossary

[SLYZ022](#) — *TI Glossary*.

This glossary lists and explains terms, acronyms, and definitions.

## 13 Mechanical, Packaging, and Orderable Information

The following pages include mechanical, packaging, and orderable information. This information is the most current data available for the designated devices. This data is subject to change without notice and revision of this document. For browser-based versions of this data sheet, refer to the left-hand navigation.

**PACKAGING INFORMATION**

Orderable part number	Status (1)	Material type (2)	Package   Pins	Package qty   Carrier	RoHS (3)	Lead finish/ Ball material (4)	MSL rating/ Peak reflow (5)	Op temp (°C)	Part marking (6)
<a href="#">CDCLVP1208RHDR</a>	Active	Production	VQFN (RHD)   28	3000   LARGE T&R	Yes	NIPDAUAG	Level-3-260C-168 HR	-40 to 85	CDCLVP 1208
CDCLVP1208RHDR.Z	Active	Production	VQFN (RHD)   28	3000   LARGE T&R	Yes	NIPDAUAG	Level-3-260C-168 HR	-40 to 85	CDCLVP 1208
<a href="#">CDCLVP1208RHDT</a>	Active	Production	VQFN (RHD)   28	250   SMALL T&R	Yes	NIPDAUAG	Level-3-260C-168 HR	-40 to 85	CDCLVP 1208
CDCLVP1208RHDT.Z	Active	Production	VQFN (RHD)   28	250   SMALL T&R	Yes	NIPDAUAG	Level-3-260C-168 HR	-40 to 85	CDCLVP 1208

(1) **Status:** For more details on status, see our [product life cycle](#).

(2) **Material type:** When designated, preproduction parts are prototypes/experimental devices, and are not yet approved or released for full production. Testing and final process, including without limitation quality assurance, reliability performance testing, and/or process qualification, may not yet be complete, and this item is subject to further changes or possible discontinuation. If available for ordering, purchases will be subject to an additional waiver at checkout, and are intended for early internal evaluation purposes only. These items are sold without warranties of any kind.

(3) **RoHS values:** Yes, No, RoHS Exempt. See the [TI RoHS Statement](#) for additional information and value definition.

(4) **Lead finish/Ball material:** Parts may have multiple material finish options. Finish options are separated by a vertical ruled line. Lead finish/Ball material values may wrap to two lines if the finish value exceeds the maximum column width.

(5) **MSL rating/Peak reflow:** The moisture sensitivity level ratings and peak solder (reflow) temperatures. In the event that a part has multiple moisture sensitivity ratings, only the lowest level per JEDEC standards is shown. Refer to the shipping label for the actual reflow temperature that will be used to mount the part to the printed circuit board.

(6) **Part marking:** There may be an additional marking, which relates to the logo, the lot trace code information, or the environmental category of the part.

Multiple part markings will be inside parentheses. Only one part marking contained in parentheses and separated by a "~" will appear on a part. If a line is indented then it is a continuation of the previous line and the two combined represent the entire part marking for that device.

**Important Information and Disclaimer:**The information provided on this page represents TI's knowledge and belief as of the date that it is provided. TI bases its knowledge and belief on information provided by third parties, and makes no representation or warranty as to the accuracy of such information. Efforts are underway to better integrate information from third parties. TI has taken and continues to take reasonable steps to provide representative and accurate information but may not have conducted destructive testing or chemical analysis on incoming materials and chemicals. TI and TI suppliers consider certain information to be proprietary, and thus CAS numbers and other limited information may not be available for release.

In no event shall TI's liability arising out of such information exceed the total purchase price of the TI part(s) at issue in this document sold by TI to Customer on an annual basis.

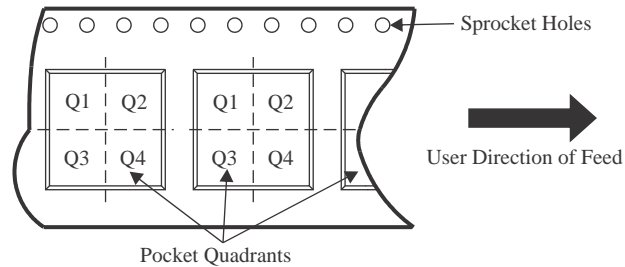

**TAPE AND REEL INFORMATION**

**QUADRANT ASSIGNMENTS FOR PIN 1 ORIENTATION IN TAPE**

\*All dimensions are nominal

Device	Package Type	Package Drawing	Pins	SPQ	Reel Diameter (mm)	Reel Width W1 (mm)	A0 (mm)	B0 (mm)	K0 (mm)	P1 (mm)	W (mm)	Pin1 Quadrant
CDCLVP1208RHDR	VQFN	RHD	28	3000	330.0	12.4	5.3	5.3	1.5	8.0	12.0	Q2

**TAPE AND REEL BOX DIMENSIONS**

\*All dimensions are nominal

Device	Package Type	Package Drawing	Pins	SPQ	Length (mm)	Width (mm)	Height (mm)
CDCLVP1208RHDR	VQFN	RHD	28	3000	350.0	350.0	43.0

**GENERIC PACKAGE VIEW**

**RHD 28**

**VQFN - 1 mm max height**

**5 x 5 mm, 0.5 mm pitch**

PLASTIC QUAD FLATPACK - NO LEAD

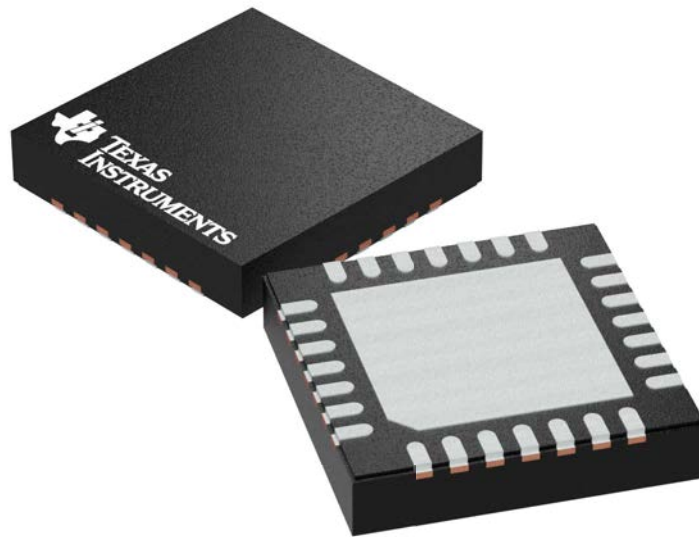

Images above are just a representation of the package family, actual package may vary.  
Refer to the product data sheet for package details.

4204400/G



# EXAMPLE BOARD LAYOUT

RHD0028B

VQFN - 1 mm max height

PLASTIC QUAD FLATPACK - NO LEAD

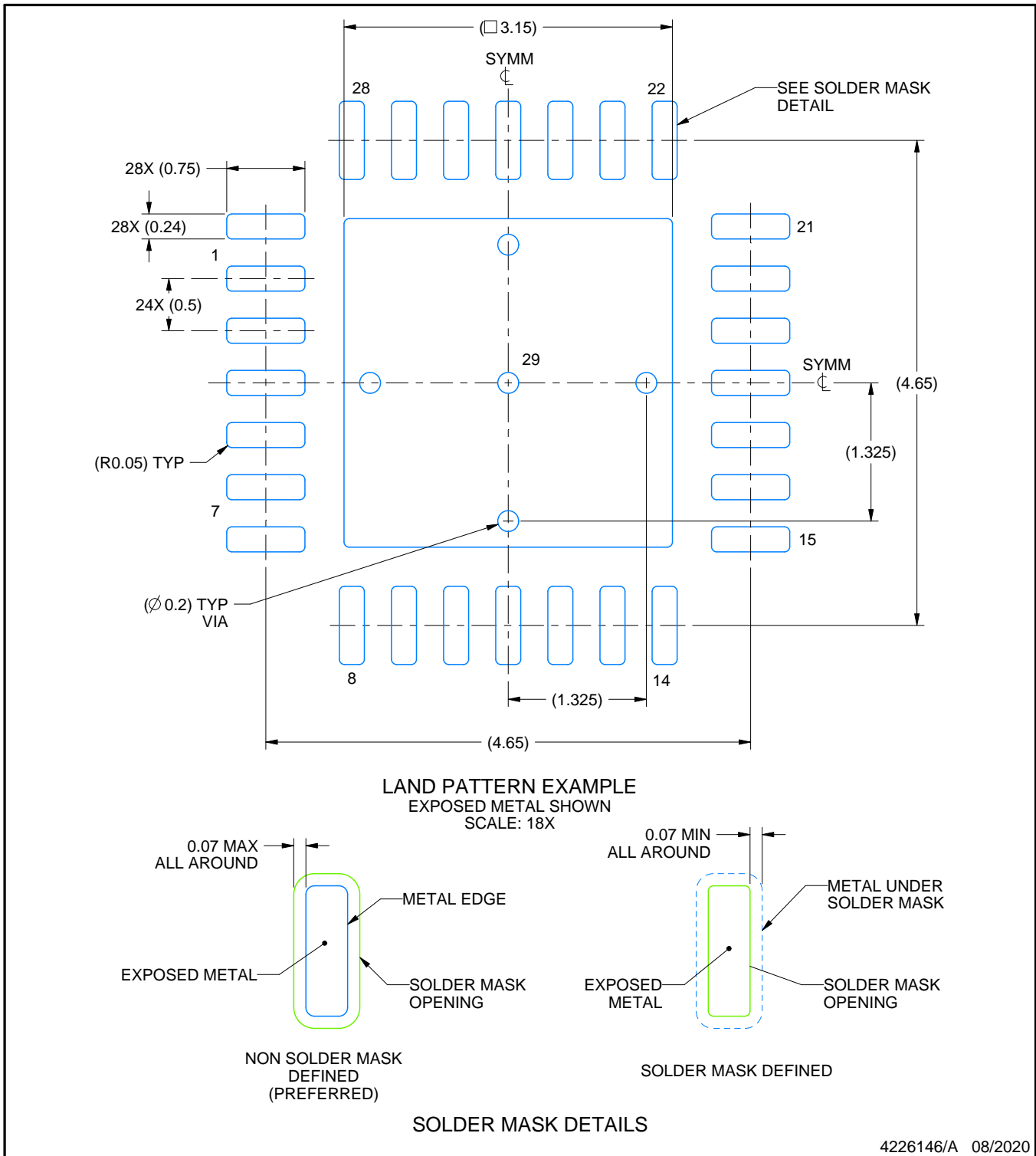

4226146/A 08/2020

NOTES: (continued)

4. This package is designed to be soldered to a thermal pad on the board. For more information, see Texas Instruments literature number SLUA271 ([www.ti.com/lit/sluea271](http://www.ti.com/lit/sluea271)).
5. Vias are optional depending on application, refer to device data sheet. If any vias are implemented, refer to their locations shown on this view. It is recommended that vias under paste be filled, plugged or tented.

# EXAMPLE STENCIL DESIGN

RHD0028B

VQFN - 1 mm max height

PLASTIC QUAD FLATPACK - NO LEAD

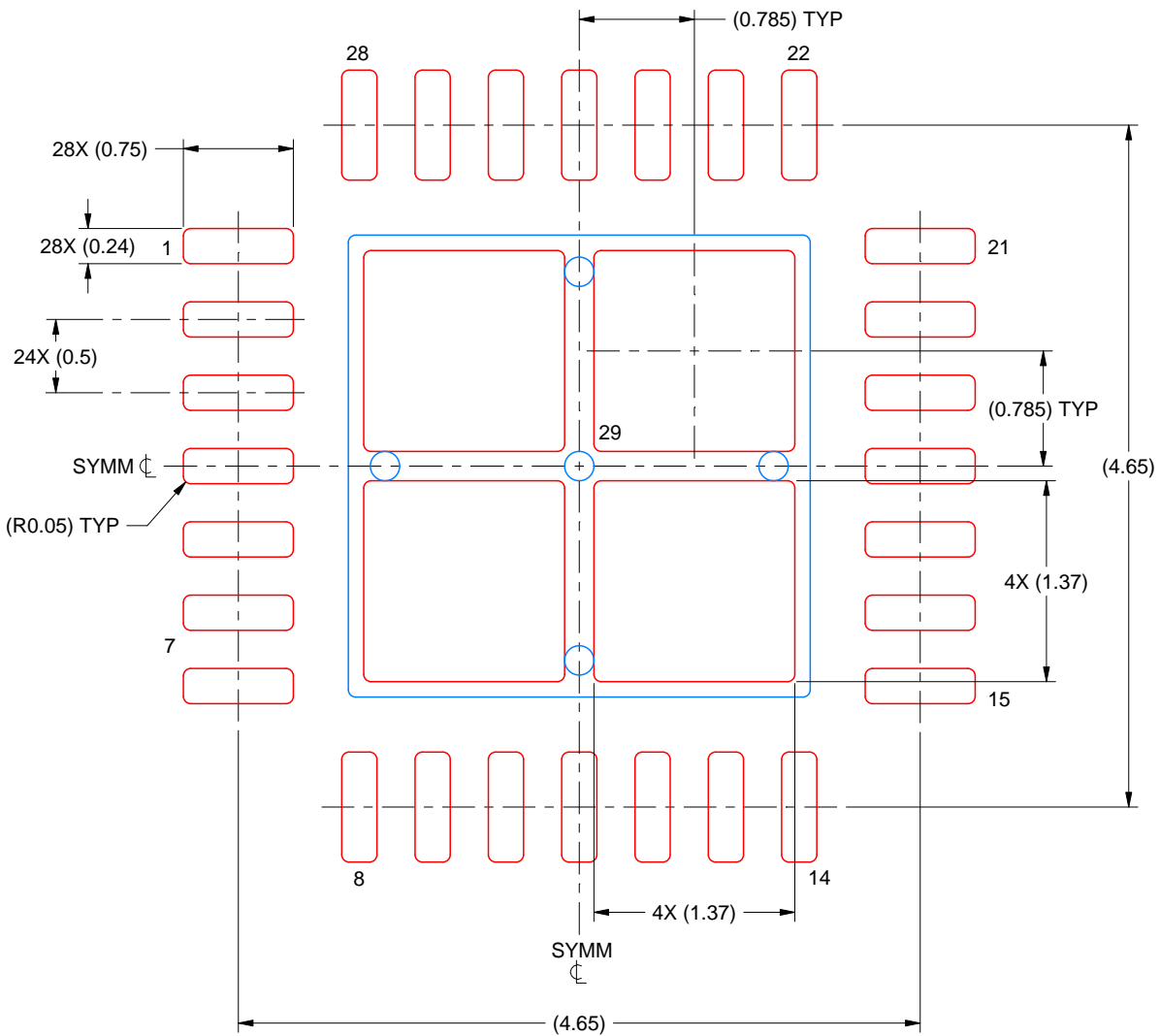

SOLDER PASTE EXAMPLE  
 BASED ON 0.125 MM THICK STENCIL  
 SCALE: 20X

EXPOSED PAD 29  
 76% PRINTED SOLDER COVERAGE BY AREA UNDER PACKAGE

4226146/A 08/2020

NOTES: (continued)

6. Laser cutting apertures with trapezoidal walls and rounded corners may offer better paste release. IPC-7525 may have alternate design recommendations.

## IMPORTANT NOTICE AND DISCLAIMER

TI PROVIDES TECHNICAL AND RELIABILITY DATA (INCLUDING DATA SHEETS), DESIGN RESOURCES (INCLUDING REFERENCE DESIGNS), APPLICATION OR OTHER DESIGN ADVICE, WEB TOOLS, SAFETY INFORMATION, AND OTHER RESOURCES "AS IS" AND WITH ALL FAULTS, AND DISCLAIMS ALL WARRANTIES, EXPRESS AND IMPLIED, INCLUDING WITHOUT LIMITATION ANY IMPLIED WARRANTIES OF MERCHANTABILITY, FITNESS FOR A PARTICULAR PURPOSE OR NON-INFRINGEMENT OF THIRD PARTY INTELLECTUAL PROPERTY RIGHTS.

These resources are intended for skilled developers designing with TI products. You are solely responsible for (1) selecting the appropriate TI products for your application, (2) designing, validating and testing your application, and (3) ensuring your application meets applicable standards, and any other safety, security, regulatory or other requirements.

These resources are subject to change without notice. TI grants you permission to use these resources only for development of an application that uses the TI products described in the resource. Other reproduction and display of these resources is prohibited. No license is granted to any other TI intellectual property right or to any third party intellectual property right. TI disclaims responsibility for, and you will fully indemnify TI and its representatives against, any claims, damages, costs, losses, and liabilities arising out of your use of these resources.

TI's products are provided subject to [TI's Terms of Sale](#) or other applicable terms available either on [ti.com](https://www.ti.com) or provided in conjunction with such TI products. TI's provision of these resources does not expand or otherwise alter TI's applicable warranties or warranty disclaimers for TI products.

TI objects to and rejects any additional or different terms you may have proposed.

Mailing Address: Texas Instruments, Post Office Box 655303, Dallas, Texas 75265  
Copyright © 2025, Texas Instruments Incorporated