

SMDJ Series

Transient Voltage Suppressor

Features

- Excellent clamping capability
- Low leakage current
- Low capacitance
- High surge capability
- Glass passivated chip
- Epoxy resin package
- Built-in strain relief
- Will not fatigue
- RoHS Compliant
- Fast response time:
typically less than 1.0ps from 0 Volts to V_{BR} min

Package

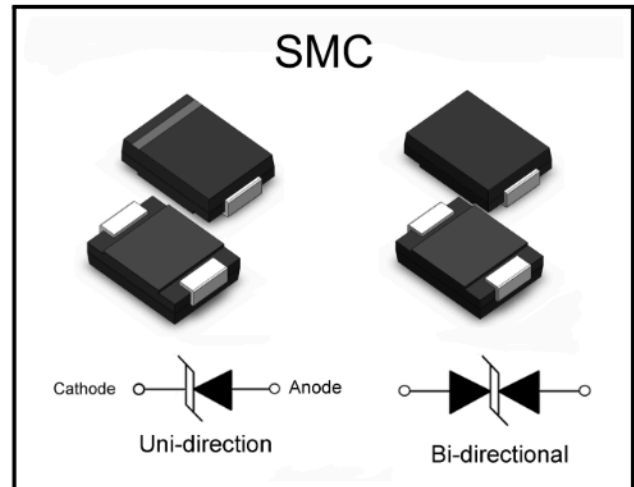

Mechanical Characteristics

- Package: SMC plastic package
- Lead Finish: Matte Tin
- Case Material: Epoxy Molding Compound
- UL Flammability Classification Rating 94V-0
- Moisture Sensitivity: Level 1 per J-STD-020

Applications

- Telecom
- Computer
- Industrial electronic
- Consumer electronic

Making Code

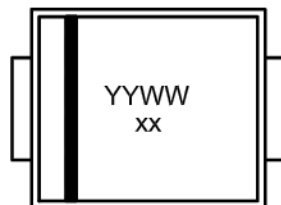

YYWW = Date Code
xx = Type Code

Summary of Packing Options

Package	Packing Description	Packing Quantity	Industry Standard
SMC	Tape/Reel, 13" reel	3000	EIA-481-1
	Tape/Reel, 7" reel	500	EIA-481-1

**BORN SEMICONDUCTOR, INC. ALL
RIGHT RESERVED**

Specifications are subject to change without notice.

Please refer to <http://www.born-tw.com> for current information. Revision: 2022-Jan-1-A



SMDJ Series

Transient Voltage Suppressor

Electrical Parameters

Parameter	Definition
C_J	Junction Capacitance - typical capacitance measured with 0V or V_R bias
I_{PP}	Peak Pulse Current - maximum rated peak impulse current
V_C	Clamping Voltage - Peak voltage measured across the suppressor at a specified I_{ppm}
V_{BR}	Breakdown Voltage - Maximum voltage that flows through the TVS at a specified test current (I_T)
I_R	Leakage Current - maximum peak off-state current measured at V_R
V_R	Peak Off-state Voltage - maximum voltage that can be applied while maintaining off state

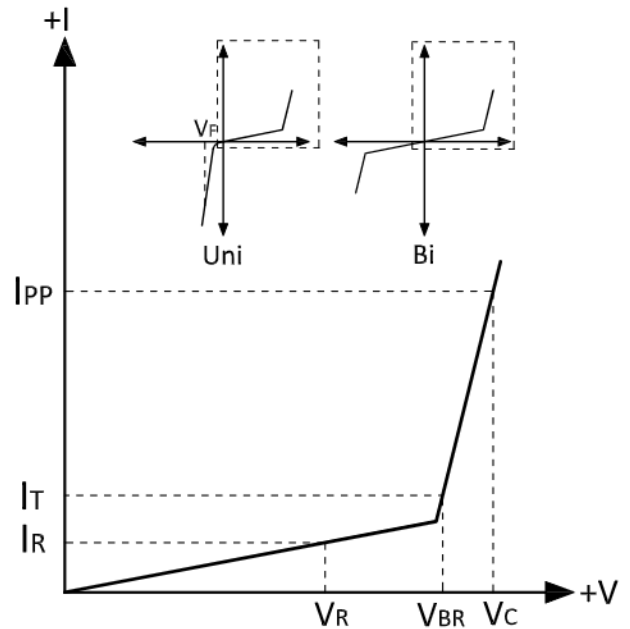

Absolute Maximum Ratings ($T_A=+25^{\circ}\text{C}$, unless otherwise noted)

Parameter	Symbol	Value	Units
Peak Pulse Power Dissipation(Note1,2)	P_{PPM}	3000	W
Steady State Power Dissipation (Note3)	P_D	6.5	W
Peak Forward Surge Current (Note4)	I_{FSM}	300	A
Maximum Instantaneous Forward Voltage at 100A (Note5)	V_{FM}	3.5/5	V
Typical Thermal Resistance Junction to Lead	$R_{\theta JL}$	15	$^{\circ}\text{C}/\text{W}$
Typical Thermal Resistance Junction to Ambient	$R_{\theta JA}$	75	$^{\circ}\text{C}/\text{W}$
Operating Junction Temperature Range	T_J	-55 to 150	$^{\circ}\text{C}$
Storage Temperature Range	T_{STG}	-55 to 150	$^{\circ}\text{C}$

Notes:

- (1) Non-repetitive current pulse , 10/1000us Waveform.
- (2) Mounted on copper pad area of 8×8mm to each terminal.
- (3) Infinite Heat Sink at $T_A = 50^{\circ}\text{C}$
- (4) Measured on 8.3ms single half sine wave or equivalent square wave, duty cycle=4 perminute maximum.
- (5) For UnidirectionalOnly, $V_{FW} < 3.5\text{V}$ for $V_{BR} \leq 200\text{V}$ and $V_{FM} < 5.0\text{V}$ for $V_{BR} \geq 201\text{V}$.



SMDJ Series

Transient Voltage Suppressor

Absolute Maximum Ratings ($T_A=+25^{\circ}\text{C}$, unless otherwise noted)

Part Number	Part Number	Marking Code		Reverse Stand-Off Voltage	Breakdown Voltage $V_{BR}@I_T$		Test Current I_T	Maximum Clamping Voltage $V_C @ I_{PP}$	Maximum Peak Pulse Current I_{PP}	Maximum Reverse Leakage $I_R @ V_R$
		(Uni)	(Bi)		(V)	Min.(V)				
SMDJ5.0A	SMDJ5.0CA	HDE	IDE	5	6.4	7	10	9.2	326.1	800
SMDJ6.0A	SMDJ6.0CA	HDG	IDG	6	6.67	7.37	10	10.3	291.3	800
SMDJ6.5A	SMDJ6.5CA	HDK	IDK	6.5	7.22	7.98	10	11.2	267.9	500
SMDJ7.0A	SMDJ7.0CA	HDM	IDM	7	7.78	8.6	10	12	250	200
SMDJ7.5A	SMDJ7.5CA	HDP	IDP	7.5	8.33	9.21	1	12.9	232.6	100
SMDJ8.0A	SMDJ8.0CA	HDR	IDR	8.0	8.89	9.83	1	13.6	220.6	50
SMDJ8.5A	SMDJ8.5CA	HDT	IDT	8.5	9.44	10.4	1	14.4	208.3	20
SMDJ9.0A	SMDJ9.0CA	HDV	IDV	9	10	11.1	1	15.4	194.8	10
SMDJ10A	SMDJ10CA	HDX	IDX	10	11.1	12.3	1	17	176.5	5
SMDJ11A	SMDJ11CA	HDZ	IDZ	11	12.2	13.5	1	18.2	164.8	2
SMDJ12A	SMDJ12CA	HEE	IEE	12	13.3	14.7	1	19.9	150.8	2
SMDJ13A	SMDJ13CA	HEG	IEG	13	14.4	15.9	1	21.5	139.5	2
SMDJ14A	SMDJ14CA	HEK	IEK	14	15.6	17.2	1	23.2	129.3	2
SMDJ15A	SMDJ15CA	HEM	IEM	15	16.7	18.5	1	24.4	123	2
SMDJ16A	SMDJ16CA	HEP	IEP	16	17.8	19.7	1	26	115.4	2
SMDJ17A	SMDJ17CA	HER	IER	17	18.9	20.9	1	27.6	108.7	2
SMDJ18A	SMDJ18CA	HET	IET	18	20	22.1	1	29.2	102.7	2
SMDJ20A	SMDJ20CA	PEV	IEV	20	22.2	24.5	1	32.4	92.6	2
SMDJ22A	SMDJ22CA	HEX	IEX	22	24.4	26.9	1	35.5	84.5	2
SMDJ24A	SMDJ24CA	HEZ	IEZ	24	26.7	29.5	1	38.9	77.1	2
SMDJ26A	SMDJ26CA	HFE	IFE	26	28.9	31.9	1	42.1	71.3	2
SMDJ28A	SMDJ28CA	HFG	IFG	28	31.1	34.4	1	45.4	66.1	2
SMDJ30A	SMDJ30CA	HFK	IFK	30	33.3	36.8	1	48.4	62	2
SMDJ33A	SMDJ33CA	HFM	IFM	33	36.7	40.6	1	53.3	56.3	2
SMDJ36A	SMDJ36CA	HFP	IFP	36	40	44.2	1	58.1	51.6	2
SMDJ40A	SMDJ40CA	HFR	IFR	40	44.4	49.1	1	64.5	46.5	2
SMDJ43A	SMDJ43CA	HFT	IFT	43	47.8	52.8	1	69.4	43.2	2
SMDJ45A	SMDJ45CA	HFV	IFV	45	50	55.3	1	72.7	41.3	2
SMDJ48A	SMDJ48CA	HFX	IFX	48	53.33	58.9	1	77.4	38.8	2
SMDJ51A	SMDJ51CA	HFZ	IFZ	51	56.7	62.7	1	82.4	36.4	2
SMDJ54A	SMDJ54CA	HGE	IGE	54	60	66.3	1	87.1	34.4	2
SMDJ58A	SMDJ58CA	HGG	IGG	58	64.4	71.2	1	93.6	32.1	2
SMDJ60A	SMDJ60CA	HGK	IGK	60	66.7	73.7	1	96.8	31	2



SMDJ Series

Transient Voltage Suppressor

Absolute Maximum Ratings ($T_A=+25^{\circ}\text{C}$, unless otherwise noted)

Part Number	Part Number	Marking Code		Reverse Stand-Off Voltage	Breakdown Voltage $V_{BR}@I_T$		Test Current I_T	Maximum Clamping Voltage $V_C @ I_{PP}$	Maximum Peak Pulse Current I_{PP}	Maximum Reverse Leakage $I_R @ V_R$
		(Uni)	(Bi)		Min.(V)	Max.(V)				
SMDJ64A	SMDJ64CA	HGM	IGM	64	71.1	78.6	1	103	29.1	2
SMDJ70A	SMDJ70CA	HGP	IGP	70	78.8	86	1	113	26.5	2
SMDJ75A	SMDJ75CA	HGR	IGR	75	83.3	92.1	1	121	24.8	2
SMDJ78A	SMDJ78CA	HGT	IGT	78	86.7	95.8	1	126	23.8	2
SMDJ85A	SMDJ85CA	HGV	IGV	85	94.4	104	1	137	21.9	2
SMDJ90A	SMDJ90CA	HGX	IGX	90	100	111	1	146	20.5	2
SMDJ100A	SMDJ100CA	HGZ	IGZ	100	111	123	1	162	18.5	2
SMDJ110A	SMDJ110CA	HHE	IHE	110	122	135	1	177	16.9	2
SMDJ120A	SMDJ120CA	HHG	IHG	120	133	147	1	193	15.5	2
SMDJ130A	SMDJ130CA	HHK	IHK	130	144	159	1	209	14.4	2
SMDJ150A	SMDJ150CA	HHM	IHM	150	167	185	1	243	12.3	2
SMDJ160A	SMDJ160CA	HHP	IHP	160	178	197	1	259	11.6	2
SMDJ170A	SMDJ170CA	HHR	IHR	170	189	209	1	275	10.9	2
SMDJ180A	SMDJ180CA	HHT	IHT	180	198	230.4	1	292	10.3	2
SMDJ220A	SMDJ220CA	HIE	IIE	220	242	281.6	1	356	8.4	2



SMDJ Series

Transient Voltage Suppressor

Ratings and Characteristic Curves ($T_A=+25^{\circ}\text{C}$, unless otherwise noted)

Figure 1: Peak Pulse Power Rating

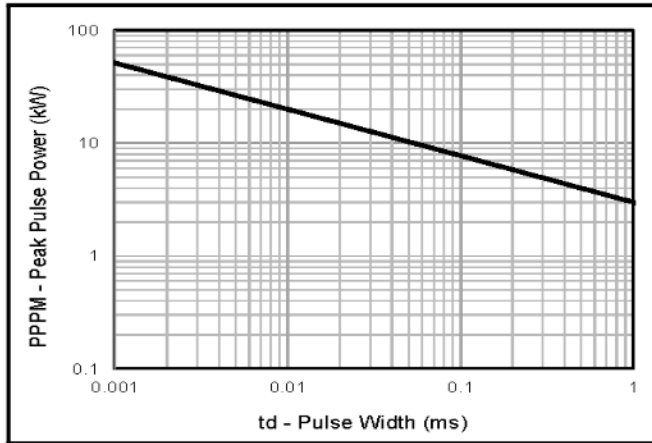

Figure 2: Pulse Derating Curve

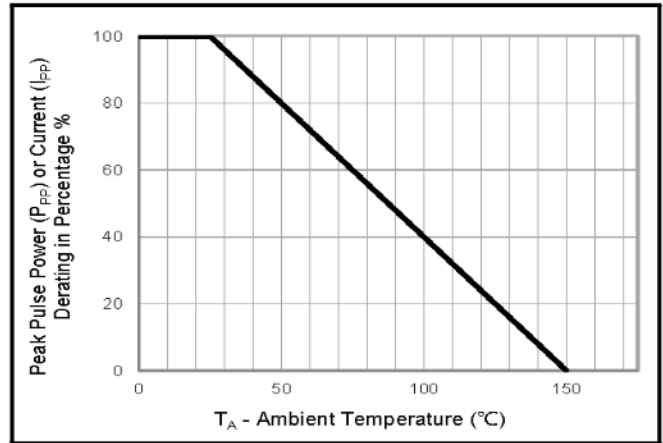

Figure 3: Pulse Waveform

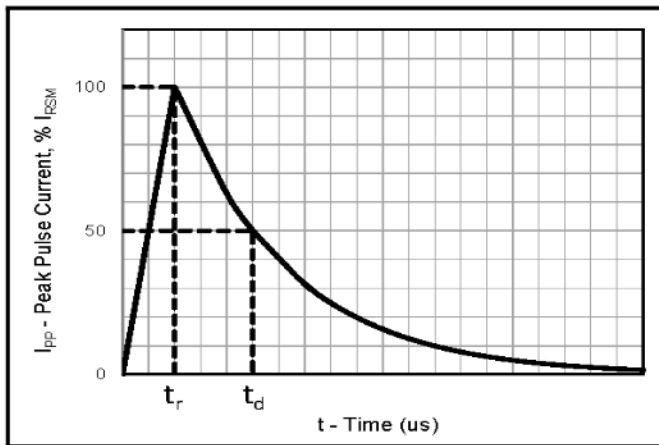

Figure 4: Typical Junction Capacitance

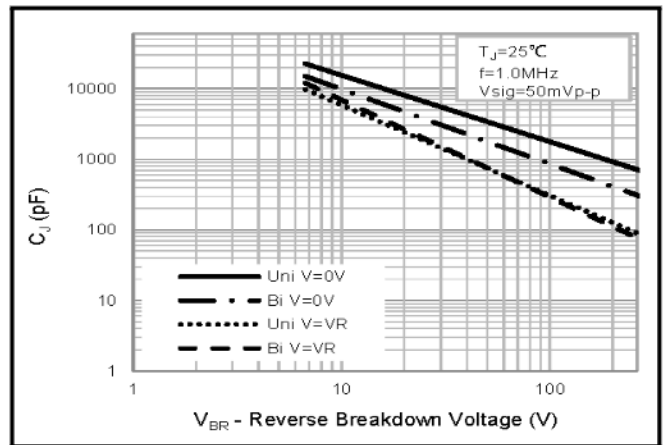

Figure 5: Steady State Power Dissipation Derating

Curve

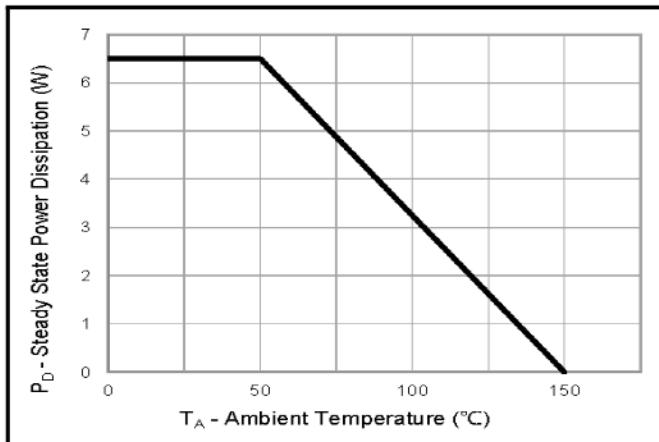
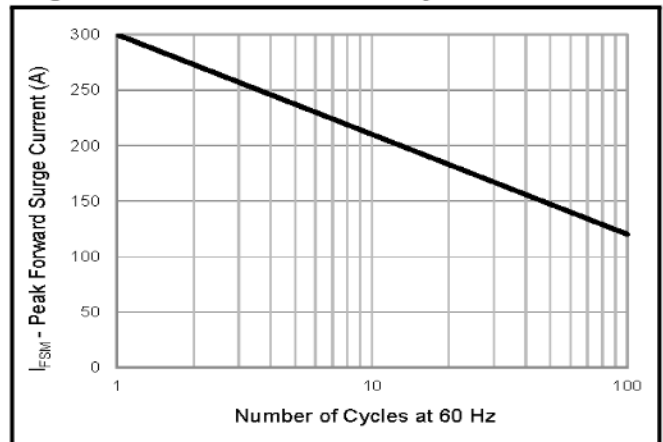

Figure 6: Maximum Non-Repetitive Peak Forward

Surge Current Uni-Directional Only



SMDJ Series

Transient Voltage Suppressor

Soldering Parameters

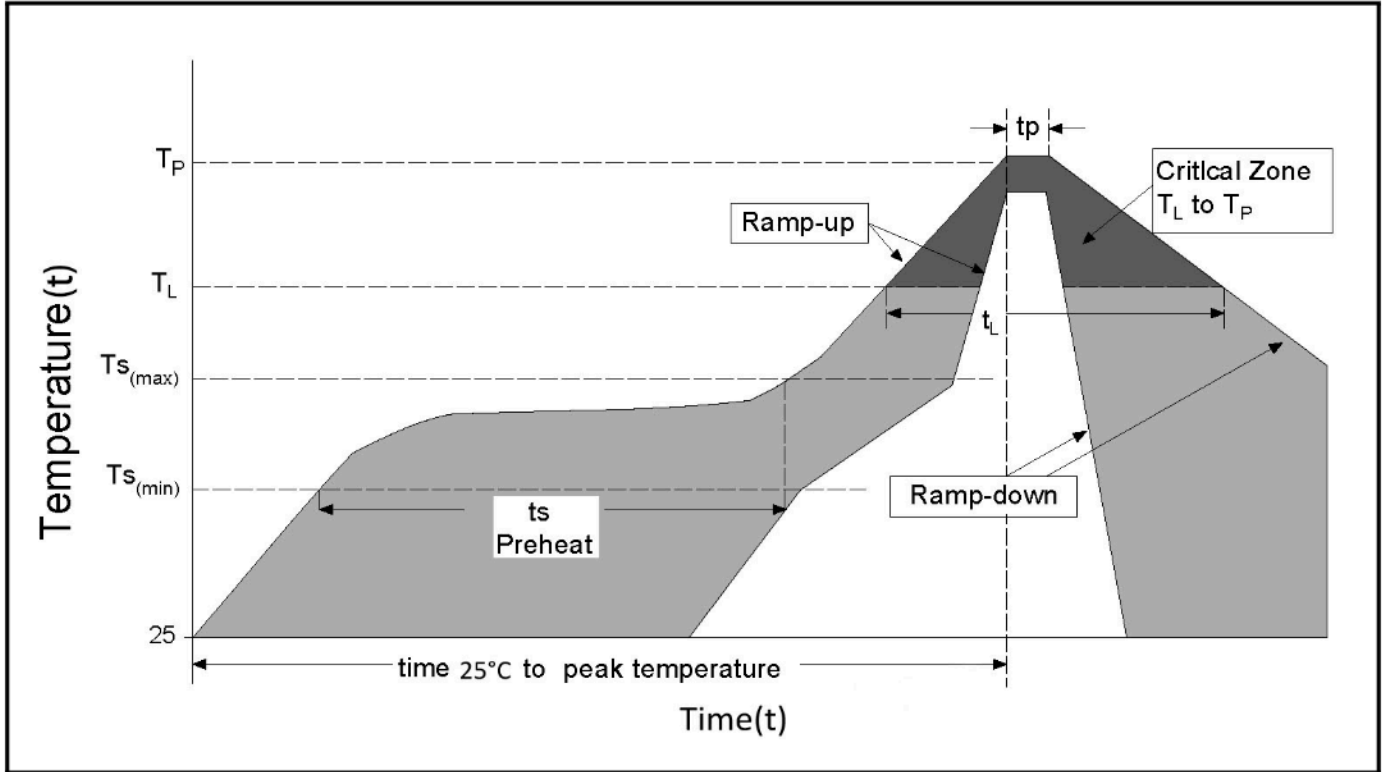

Reflow Condition		Lead-free assembly
Pre Heat	- Temperature Min ($T_{S(min)}$)	150°C
	- Temperature Max ($T_{S(max)}$)	200°C
	- Time (min to max) (t_s)	60 - 180 secs
Average ramp up rate (Liquidus Temp (T_L) to peak)		3°C/second max
$T_{S(max)}$ to T_L - Ramp-up Rate		3°C/second max
Reflow	- Temperature (T_L) (Liquidus)	217°C
	- Time (t_L)	60 - 150 secs
Peak Temperature (T_P)		260 ^{+0/-5} °C
Time within 5°C of actual peak Temperature (t_p)		20 - 40 secs
Ramp-down Rate		6°C/second max
Time 25°C to peak Temperature (t)		8 minutes Max.
Do not exceed		260°C



SMDJ Series

Transient Voltage Suppressor

Package Mechanical Data - SMC

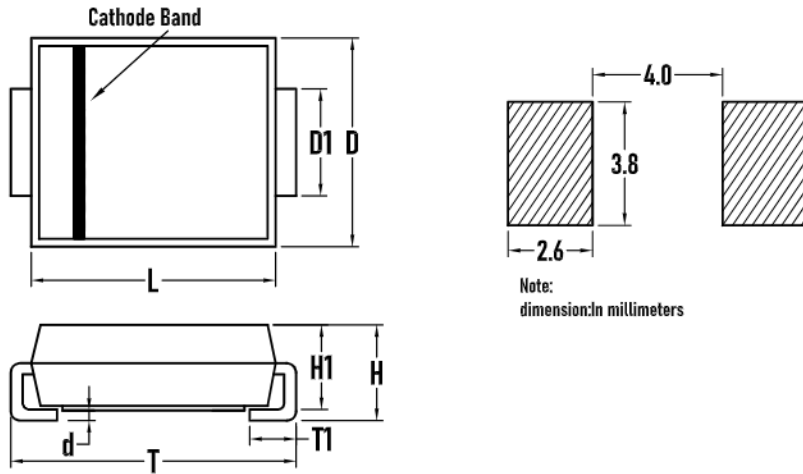

SYMBOL	MILLIMETER		Inches	
	MIN	MAX	MIN	MAX
D	5.5	6.1	0.217	0.240
D1	2.7	3.3	0.106	0.130
T	7.4	8.4	0.291	0.331
T1	0.8	1.6	0.031	0.063
d	-	0.3	-	0.012
H1	2.0	2.6	0.079	0.102
H	2.1	2.7	0.083	0.106
L	6.5	7.1	0.256	0.280

Packaging Tape - SMC

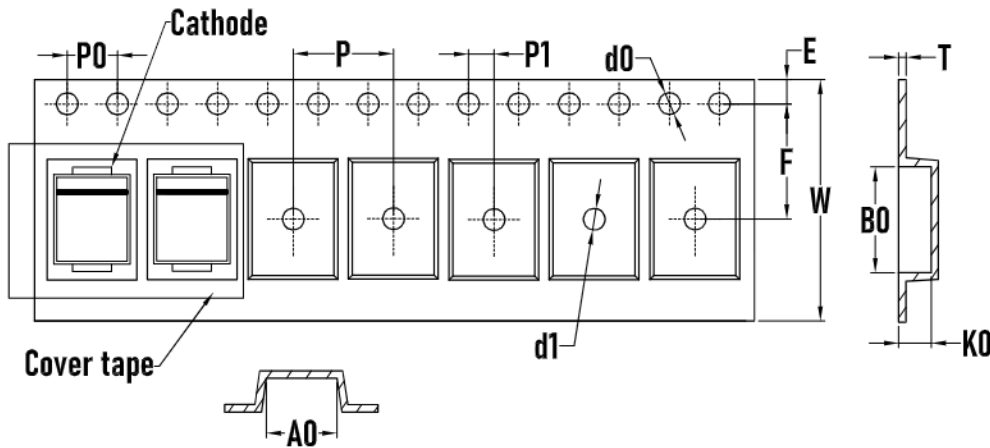

SYMBOL	MILLIMETER
A0	6.00±0.1
B0	8.25±0.02
d0	1.50±0.1
d1	1.50±0.1
E	1.75±0.1
F	7.50±0.1
K0	2.70±0.1
P	8.00±0.1
P0	4.00±0.1
P1	2.00±0.05
W	16.00±0.1
T	0.22±0.02

Packaging Reel

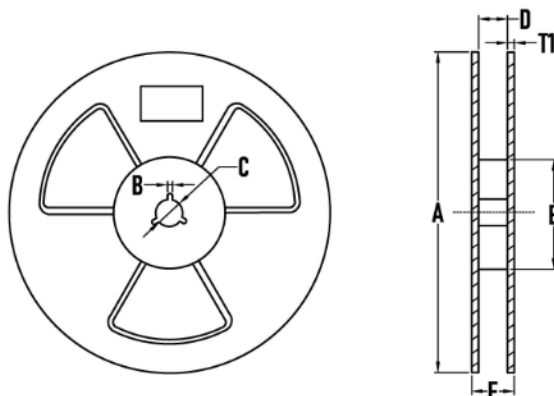

SYMBOL	MILLIMETER
A	323±2
B	3.0±0.2
C	15.0±0.5
D	16±2
E	73±2
T1	2.2±0.2
Quantity	3000PCS

**BORN SEMICONDUCTOR, INC. ALL
RIGHT RESERVED**

Specifications are subject to change without notice.

Please refer to <http://www.born-tw.com> for current information.

Revision: 2022-Jan-1-A

