

REVISION			
LTR	DESCRIPTION	DATE	APP
A0	NEW RELEASE	05/20/2020	PECK

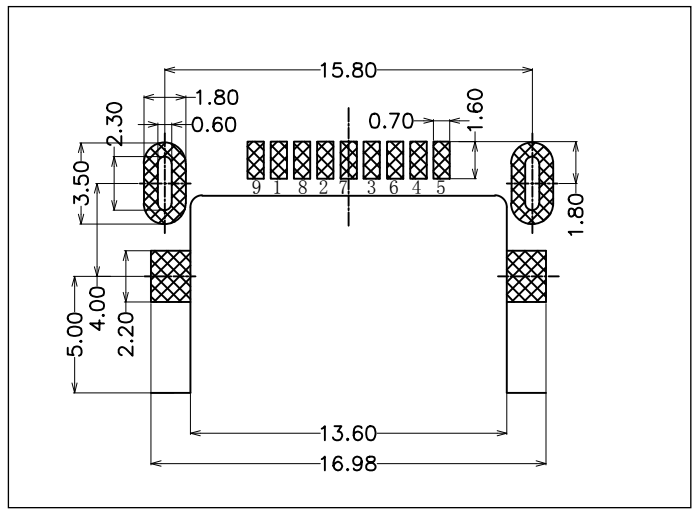
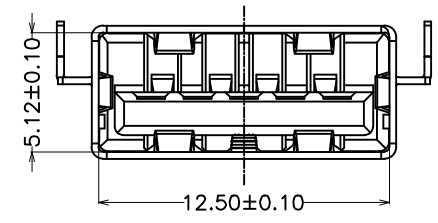
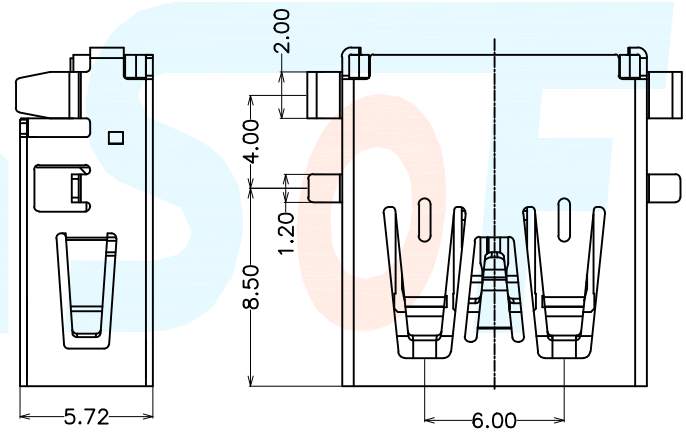
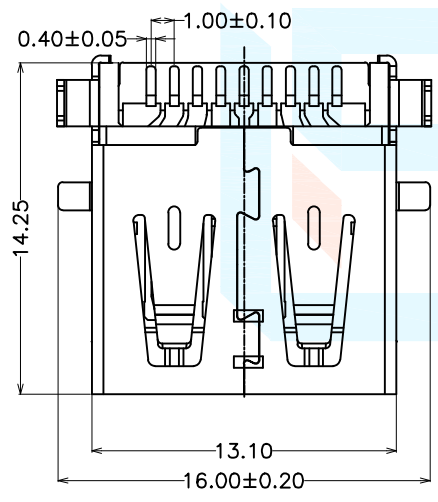
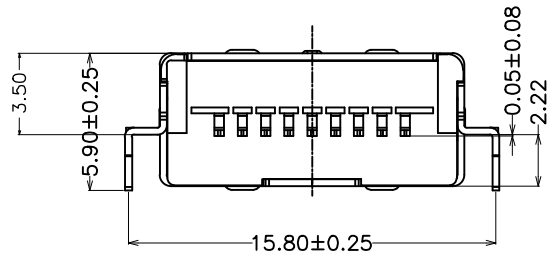

Note:

1.Material:

- 1.1 Housing: High temperature thermoplastic,UL94v-0
- 1.2 Orbit: High temperature thermoplastic,UL94v-0
- 1.3 Contact: copper alloy;
Gold plated contact area;Tin plated solder area
- 1.4 Shell:Stainless;Ni plated allover;
Gold plated solder area

2.Specification:

- 2.1 Current rating: 0.5A Max
- 2.2 Voltage rating: 5V DC
- 2.3 Dielectric withstanding voltage:
500V(AC) for 1 min.
- 2.4 Contact resistance: 100mΩ Max.
- 2.5 Insulation resistance: 1000MΩ min.
- 2.6 Temperature range: -25°C~85°C
- 2.7 Mating cycle:5000 cycles min
- 2.8 Insert force: 40N Max
Extraction force: 0.5~40N

DIMENSION CLASSIFICATION
 ■ : CRITICAL
 ☒ : MAJOR

台灣碩方精密電子科技有限公司
 TAIWAN SOFNG PRECISION ELECTRONIC CO., LTD



TOLERANCE TABLE		TITLE	3.0USB连接器[沉板式] L14.25-W13.1-H5.7mm		開關, 连接器 SOFNG	
.X	± 0.40	PART NO.	U30-06E 卧式外壳双插件	SERIES	SD106	
.XX	± 0.25	APPROVED	Peck	DWG NO.	SOF-U30-06E	
.XXX	± 0.10	CHECKED	Paul	SCALE	1:1	UNIT mm SIZE A4
ANGLE	± 2°	DRAWIN	David	REV	AO	SHEET NO. 1/1