

**Shenzhen DreamLNK Technology Co., Ltd.**  
**深圳市骏晔科技有限公司**

2.4G/5G Dual-band 5dBi Rubber Rod Antenna

**Product Specification**

Client Name		Frequency Band	2.4/5G WIFI
Wire Name		Version	A1
Customer's Part Number		DreamLNK's Part Number	DL-J004
RF Designer	Fagan Xu	RF Manager	Knight Ai
Structural Designer		Structural Design Manager	
Technical Director		Date	2019-05-20

Client confirmation:

Whether the product meets your requirements?  OK  NG

# Contents

Cover .....	1
Contents .....	2
1. Photos .....	3
2. Parameters .....	3
3. S11 Data .....	4
4. Structure Diagram .....	8
5. Environmental Reliability Testing Report .....	9
6. Contact Us .....	10

The information provided by us should be kept strictly confidential, and it is not allowed to disclose to anyone else or other companies, without prior written consent

---

## 1. Photos



## 2. Parameters

Testing Parameters			
Product Name	Rubber Rod Antenna	Model No	DL-J004
Electrical Specifications			
Frequency Range	2400~2500MHz; 5150~5850MHz	Polarization	Linear, Vertical
Input Impedance	50 $\Omega$	Radiation direction	Omni-directional
VSWR	$\leq 3.0$	Power Capacity	10W
Peak Gain	2.0dBi	Return Loss	-10dB (Max.)
Mechanical Specifications			
Dimensions	D13*197mm	Color	Black
Connector Model	SMA-J (male)	Cable Length	/
Antenna Material	ABS+PS	Storage Temp.	-20 ~ +70 $^{\circ}$ C
Working Temp.	-20 $^{\circ}$ C ~ +65 $^{\circ}$ C	Relative Humidity	40~85%

### 3. S11 Data (VSWR, Return loss, Smith)

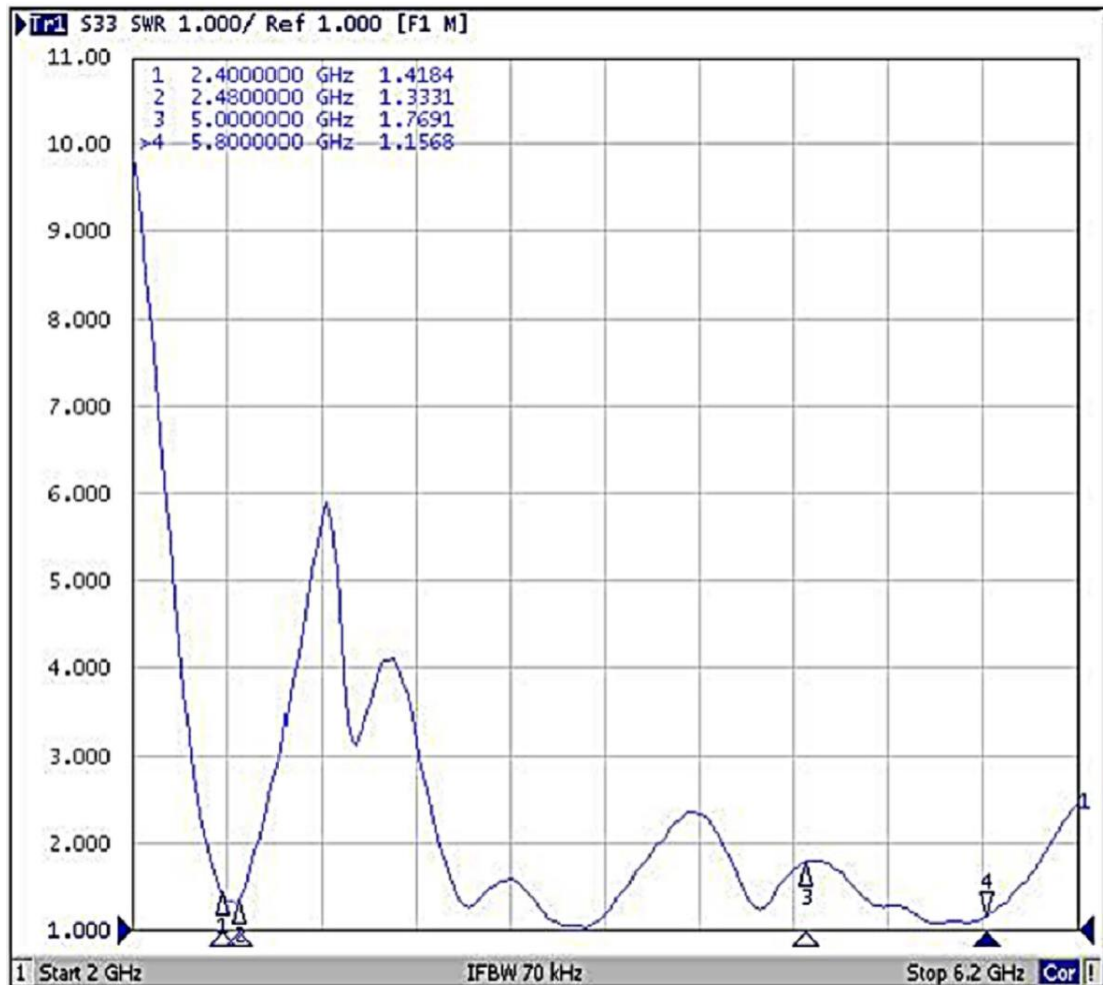

Passive efficiency

**2400.000MHz H**

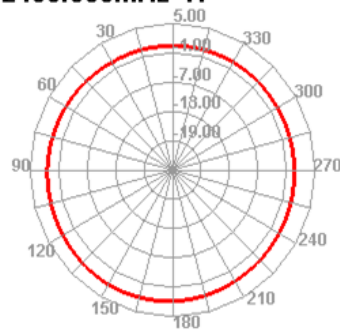

**2400.000MHz E1**

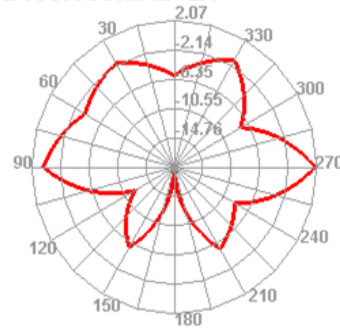

The information provided by us should be kept strictly confidential, and it is not allowed to disclose to anyone else or other companies, without prior written consent

---

**2500.000MHz H**

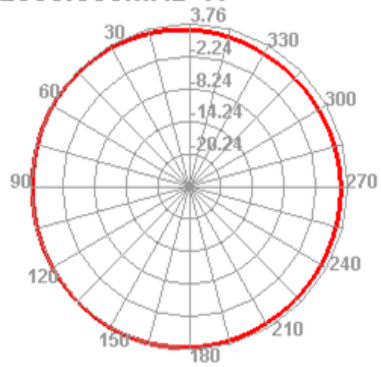

**2500.000MHz E1**

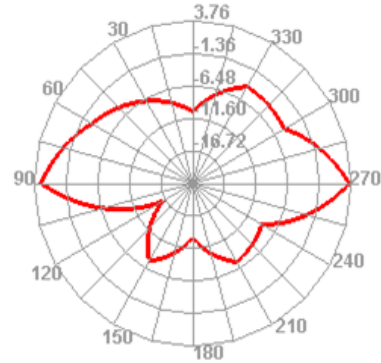

**2500.000MHz E2**

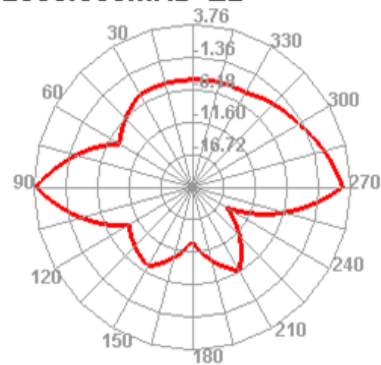

**5150.000MHz H**

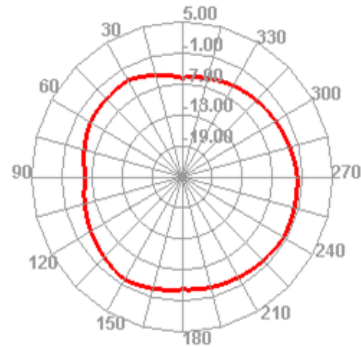

**5150.000MHz E1**

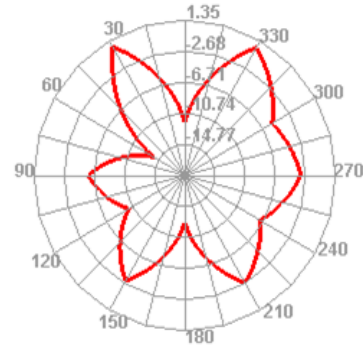

**5150.000MHz E2**

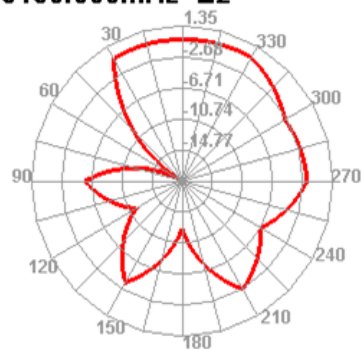

The information provided by us should be kept strictly confidential, and it is not allowed to disclose to anyone else or other companies, without prior written consent

---

**5500.000MHz H**

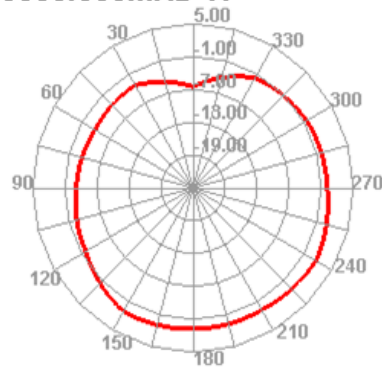

**5500.000MHz E1**

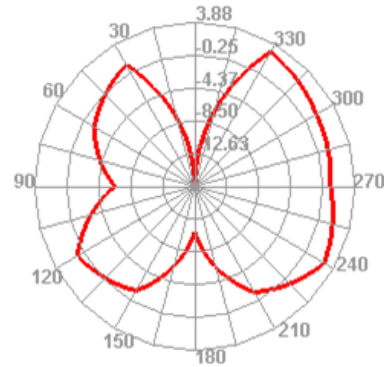

**5500.000MHz E2**

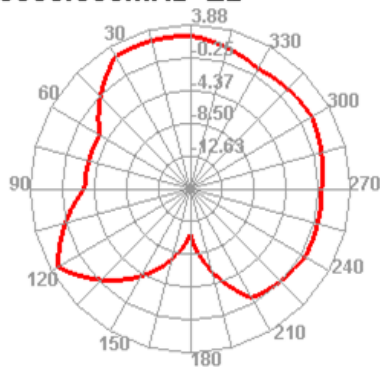

**5850.000MHz H**

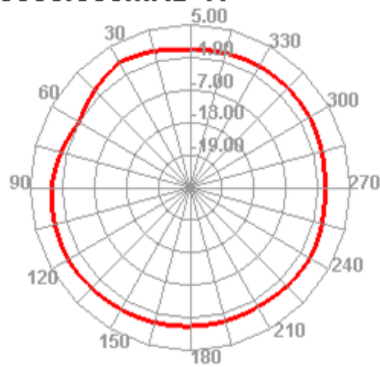

**5850.000MHz E1**

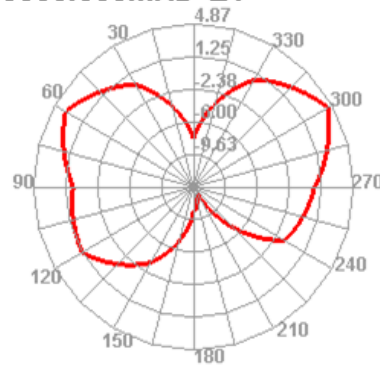

**5850.000MHz E2**

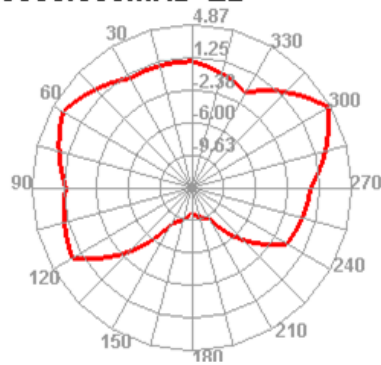

#### 4. Structure diagram

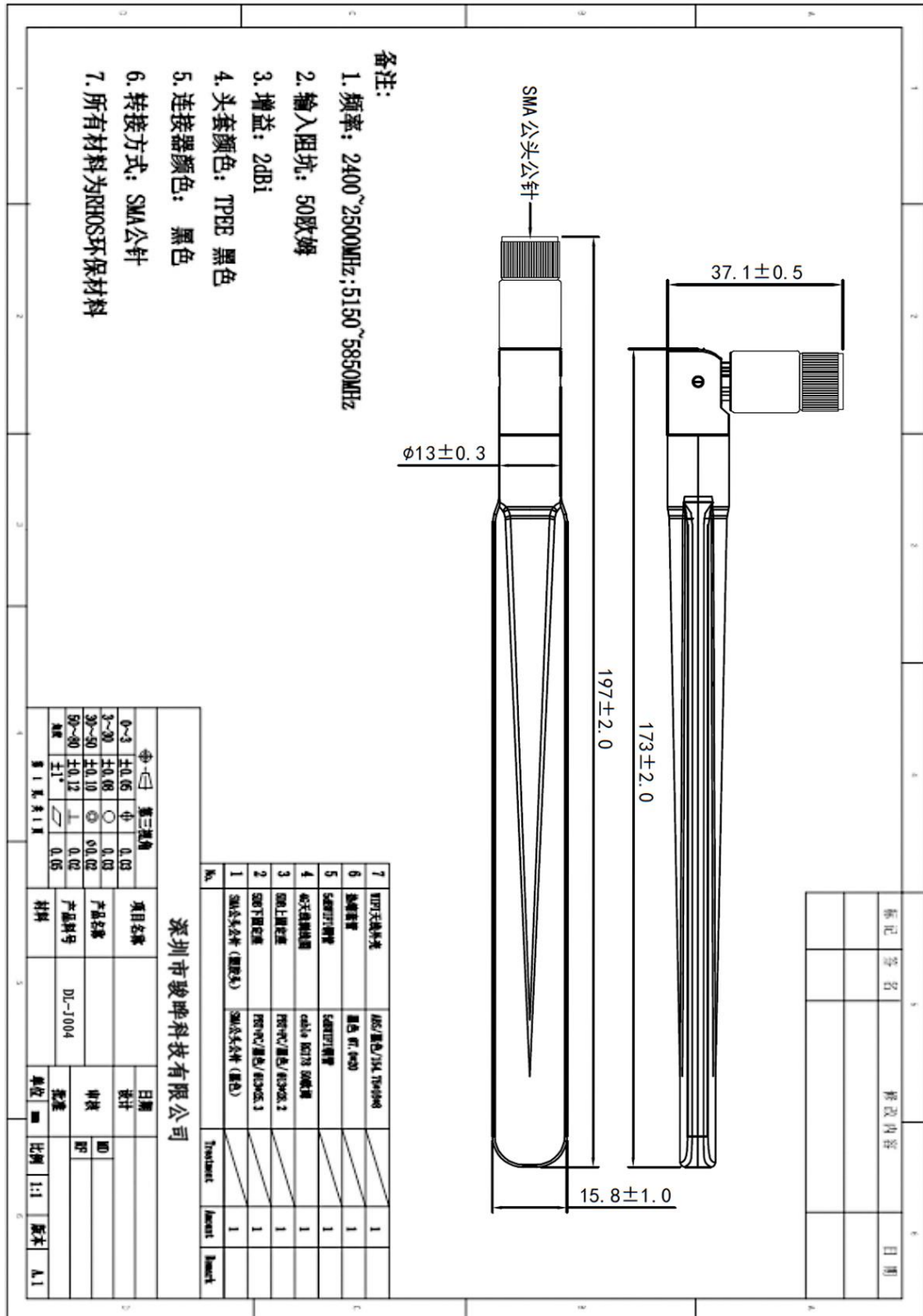

**Note:** The antenna design process needs to consider the placement position, angle, distance/ height (from the floor and from the PCB substrate), which is highly related to the product shape and

structure, the position of the RF module signal input and output interface, as well as the position of the interference source inside the product etc.

The  $\pi$ -type network is reserved to match the antenna. When debugging the antenna, be sure to provide the entire product casing and internal PCBA function board, please also take into account external interference sources and parasitic capacitance, so that the antenna achieves the best performance index and working efficiency.

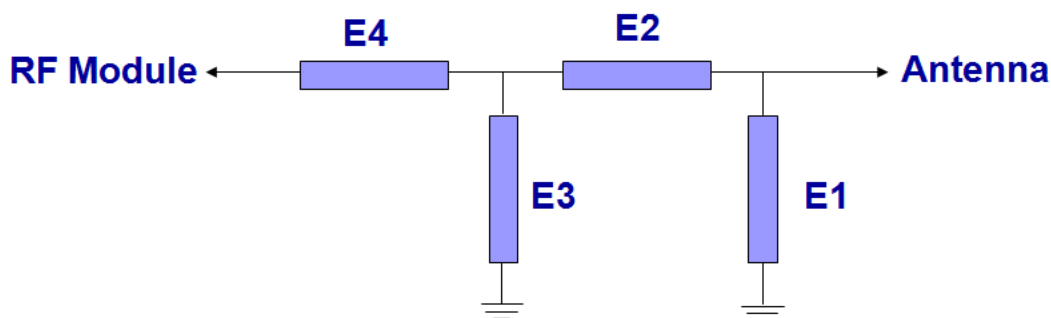

The above picture is just FYI. The PCB trace of the matching network refers to the 0.5mm line width, and the grounding on both sides of the network refers to the 0.35mm pitch to maintain good impedance characteristics.

## 5. Environmental reliability experiment report

Item	Test condition	Specification
Storage environment	Tested temperature, humidity and air pressure as following without specifying: 1. The temperature is -30 °C ~ + 80 °C 2. Relative humidity is 45% -85% 3. The air pressure is 86kpa-106kpa	The electrical mechanical performance is normal
High and low temperature test	Perform 5 cycles between 70 °C and 40 °C, then check the appearance quality, under normal conditions 1-2H	The size should meet the requirements for mechanical and electrical performance
Resistant to constant heat and humidity	Test Relative humidity: 95 ± 3%, Test temperature: 40 °C. After continuous 2H running, take out the sample, and measure its electrical properties within 5 minutes, put the sample in a normal condition for another 1-2H, check the appearance quality	The size should meet the standard, and meet for mechanical and electrical performance
Vibration test	Vibration frequency range 10-55HZ, displacement amplitude: 0.35MM, acceleration amplitude: 50.0M / S, frequency of sweeping cycle: 30 times	Normal electrical and mechanical performance
Drop test	1M high-altitude free fall 3 times, in the direction of mutually perpendicular axes	Normal electrical and mechanical performance

The information provided by us should be kept strictly confidential, and it is not allowed to disclose to anyone else or other companies, without prior written consent

---

## 6. Contact us

### Shenzhen DreamLnk Technology Co., Ltd

★ Data collection, Smart home, Internet of Things applications, Wireless remote control technology, Remote active RFID, Antennas ★

**Office Add.:** 602-603, Unit C, Zone A, Huameiju Business Center, Xinhua Rd., Bao'an District, Shenzhen, Guangdong Province, China

**Factory Add.:** Huazhi Innovation Valley, No. 7 Yuhua Street, 138 Industrial Zone, Tangxia Town, Dongguan, Guangdong Province, China