

FOC-V14-F1ZNI-EM/SJO - Panel-mount frame



1413981

<https://www.phoenixcontact.com/us/products/1413981>

Please be informed that the data shown in this PDF document is generated from our online catalog. Please find the complete data in the user documentation. Our general terms of use for downloads are valid.



RJ45 panel mounting frame for transceiver, IP67, for push-pull interlocking, metal, for square mounting cutout, with seal and mounting screws

Your advantages

- High reliability with comprehensive quality assurance measures
- Intuitive front-panel operation and clear control cabinet layout thanks to uniform design

Commercial data

Item number	1413981
Packing unit	1 pc
Minimum order quantity	1 pc
Sales key	AB17
Product key	ABNODF
Catalog page	Page 369 (C-2-2019)
GTIN	4055626082424
Weight per piece (including packing)	25.2 g
Weight per piece (excluding packing)	25 g
Customs tariff number	85389099
Country of origin	DE

Technical data

Notes

General	This product corresponds to the PROFINET Cabling and Interconnection Technology Guideline for PROFINET regulations, version 2.00, order no: 2.252, Chapter 8.2 Connectors for Outside Environment (Balanced cabling) and chapter 13 Application specific Cabling and Interconnection Technology (AIDA)
---------	--

Product properties

Product type	Panel-mount frame
Type	SC-RJ
Number of positions	2
Connection profile	SC-RJ

Data management status

Article revision	01
------------------	----

Insulation characteristics

Degree of pollution	2
---------------------	---

Electrical properties

Transmission medium	FO
---------------------	----

Dimensions

Width	22.2 mm
Height	42 mm

Mechanical characteristics

Ferrule diameter	2.50 mm
------------------	---------

Material specifications

Material	Metal
Flammability rating according to UL 94	V0
Seal material	NBR
Housing material	Metal
Housing surface material	nickel-plated

Cable/line

External cable diameter	≤ 10.00 mm (of 5 mm)
Resistance to oil	yes
Flame resistance	yes

Environmental and real-life conditions

Ambient conditions

FOC-V14-F1ZNI-EM/SJO - Panel-mount frame



1413981

<https://www.phoenixcontact.com/us/products/1413981>

Degree of protection	IP65/IP67
Ambient temperature (operation)	-40 °C ... 70 °C
Ambient temperature (storage/transport)	-40 °C ... 70 °C
Ambient temperature (assembly)	-10 °C ... 40 °C
Resistance to oil	yes

Standards and regulations

Flame resistance	yes
Resistance to oil	yes

FOC-V14-F1ZNI-EM/SJO - Panel-mount frame



1413981

<https://www.phoenixcontact.com/us/products/1413981>

Drawings

Drilling plan/solder pad geometry

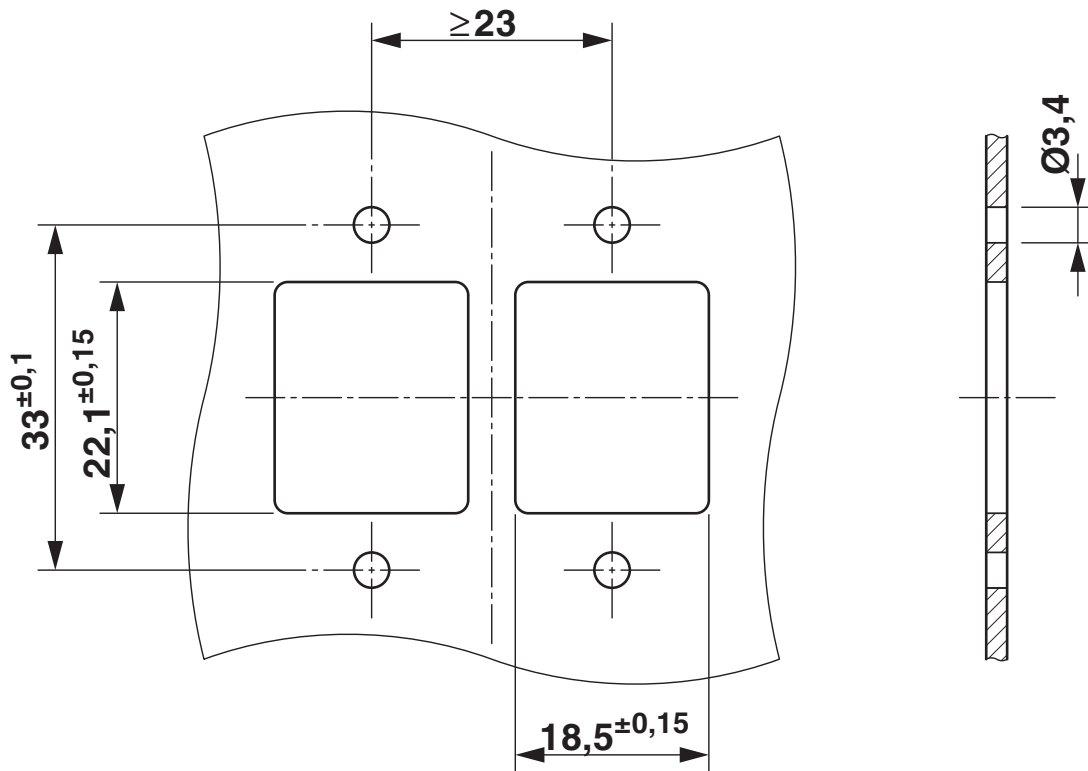

FOC-V14-F1ZNI-EM/SJO - Panel-mount frame



1413981

<https://www.phoenixcontact.com/us/products/1413981>

Classifications

ECLASS

ECLASS-11.0	27440210
ECLASS-12.0	27440210
ECLASS-13.0	27440210

ETIM

ETIM 9.0	EC002310
----------	----------

UNSPSC

UNSPSC 21.0	39121400
-------------	----------

FOC-V14-F1ZNI-EM/SJO - Panel-mount frame



1413981

<https://www.phoenixcontact.com/us/products/1413981>

Environmental product compliance

EU RoHS

Fulfills EU RoHS substance requirements	Yes, No exemptions
---	--------------------

China RoHS

Environment friendly use period (EFUP)	EFUP-E
	No hazardous substances above the limits

EU REACH SVHC

REACH candidate substance (CAS No.)	No substance above 0.1 wt%
-------------------------------------	----------------------------

Phoenix Contact 2024 © - all rights reserved
<https://www.phoenixcontact.com>

Phoenix Contact USA
586 Fulling Mill Road
Middletown, PA 17057, United States
(+717) 944-1300
info@phoenixcon.com