

标记 MARK	ECN编号/变更内容 ECN NO/DEFINITION				修改 REVISE	日期 DATE	核准 APPROVE		
CKI	DIM A	DIM B	DIM C	DIM D	CKI	DIM A	DIM B	DIM C	DIM D
4	1.50	2.56	7.60	5.20	34	16.50	17.56	22.60	5.20
5	2.00	3.06	8.10	5.20	35	17.00	18.06	23.10	5.75
6	2.50	3.56	8.60	5.20	36	17.50	18.56	23.60	5.75
7	3.00	4.06	9.10	5.20	37	18.00	19.06	24.10	5.75
8	3.50	4.56	9.60	5.20	38	18.50	19.56	24.60	5.75
9	4.00	5.06	10.10	5.20	39	19.00	20.06	25.10	5.75
10	4.50	5.56	10.60	5.20	40	19.50	20.56	25.60	5.75
11	5.00	6.06	11.10	5.20	41	20.00	21.06	26.10	5.75
12	5.50	6.56	11.60	5.20	42	20.50	21.56	26.60	5.75
13	6.00	7.06	12.10	5.20	43	21.00	22.06	27.10	5.75
14	6.50	7.56	12.60	5.20	44	21.50	22.56	27.60	5.75
15	7.00	8.06	13.10	5.20	45	22.00	23.06	28.10	5.75
16	7.50	8.56	13.60	5.20	46	22.50	23.56	28.60	5.75
17	8.00	9.06	14.10	5.20	47	23.00	24.06	29.10	5.75
18	8.50	9.56	14.60	5.20	48	23.50	24.56	29.60	5.75
19	9.00	10.06	15.10	5.20	49	24.00	25.06	30.10	5.75
20	9.50	10.56	15.60	5.20	50	24.50	25.56	30.60	5.75
21	10.00	11.06	16.10	5.20	51	25.00	26.06	31.10	5.75
22	10.50	11.56	16.60	5.20	52	25.50	26.56	31.60	5.75
23	11.00	12.06	17.10	5.20	53	26.00	27.06	32.10	5.75
24	11.50	12.56	17.60	5.20	54	26.50	27.56	32.60	5.75
25	12.00	13.06	18.10	5.20	55	27.00	28.06	33.10	5.75
26	12.50	13.56	18.60	5.20	56	27.50	28.56	33.60	5.75
27	13.00	14.06	19.10	5.20	57	28.00	29.06	34.10	5.75
28	13.50	14.56	19.60	5.20	58	28.50	29.56	34.60	5.75
29	14.00	15.06	20.10	5.20	59	29.00	30.06	35.10	5.75
30	14.50	15.56	20.60	5.20	60	29.50	30.56	35.60	5.75
31	15.00	16.06	21.10	5.20	61	30.00	31.06	36.10	5.75
32	15.50	16.56	21.60	5.20	64	31.50	32.56	37.60	5.75
33	16.00	17.06	22.10	5.20	65	32.00	33.06	38.10	5.75

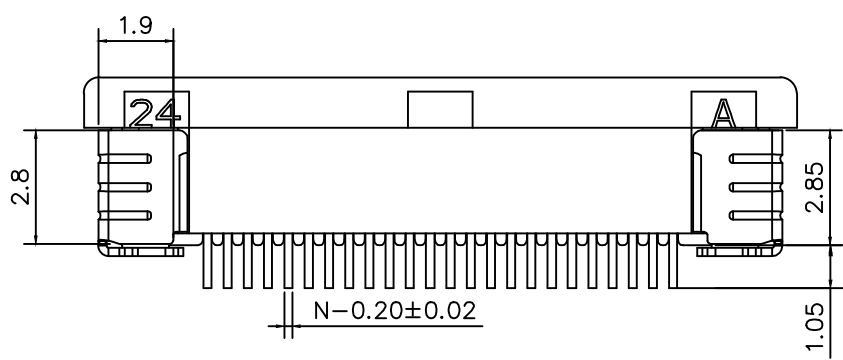

技术指标:

- 1. 温度范围: -25°C~85°C
- 2. 额定电压: 50V, AC/DC (等效)
- 3. 接触电阻: ≤0.03Ω
- 4. 绝缘电阻: ≥500MΩ

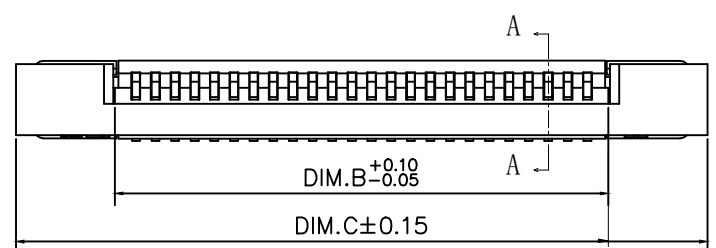
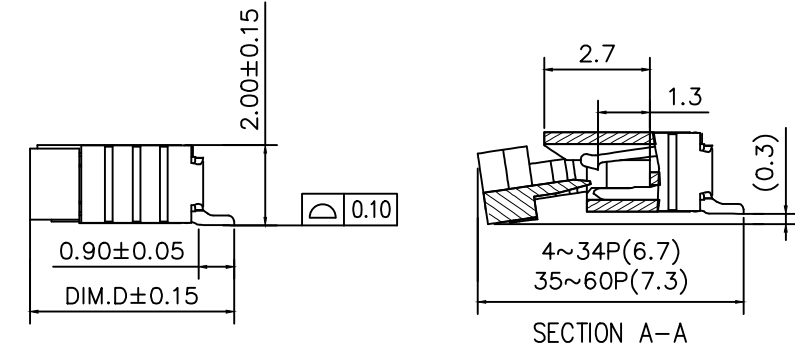
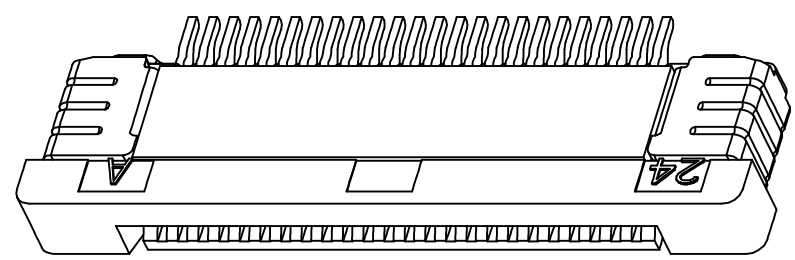
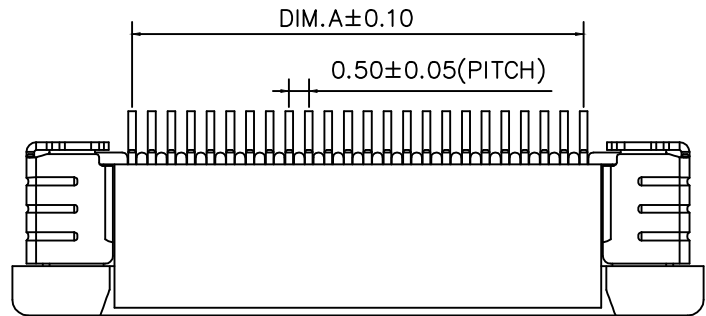
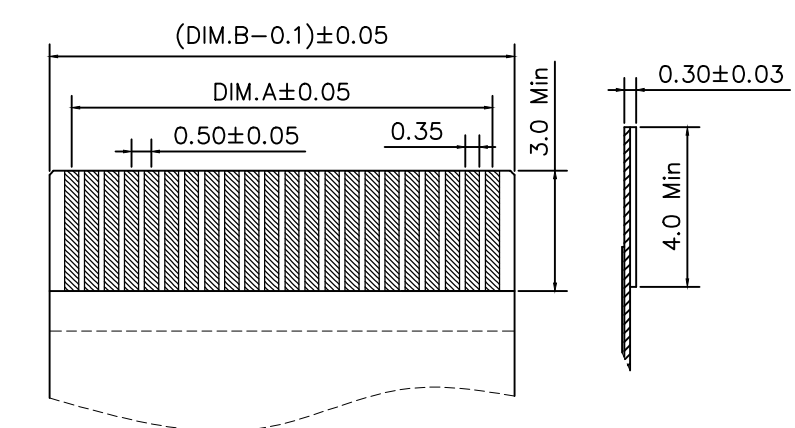

适用扁平线(Applicable Flat Cable)

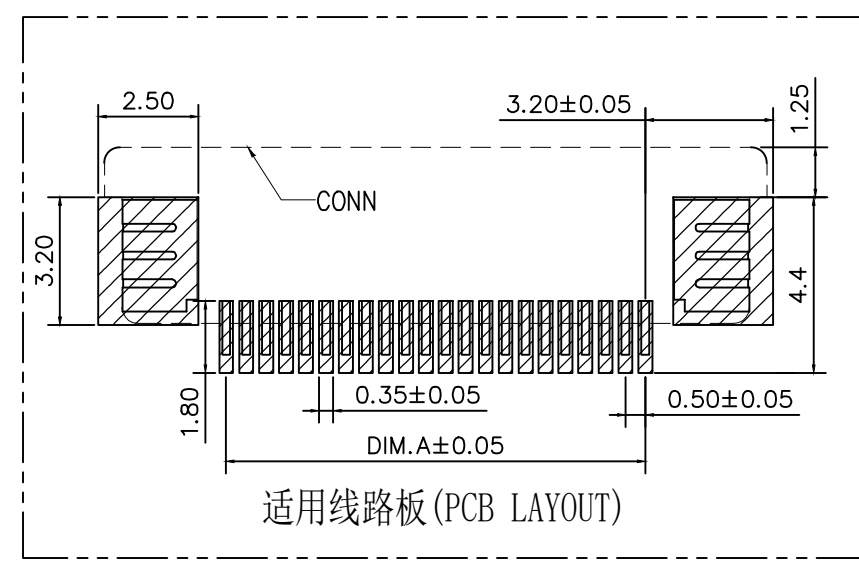

适用线路板(PCB LAYOUT)

2	端子	铜	镀锡	
1	胶芯	LCP	本色	
序号	品名	材质	电镀/颜色	备注

**深圳市虹成电子有限公司**

品名: FPC座  
 TITLE: FPC座  
 料号: HC-FPC-0.5-6P-CSH20  
 PART NO: HC-FPC-0.5-6P-CSH20

GENERAL TOLERANCES (UNLESS SPECIFIED) 比列 SCALE 1:1

X. ±0.50 .XX ±0.10 单位 UNIT MM 制图 DRAW AhYe

.X ±0.20 .XXX ±0.05 张数 PART NO 1 OF 1 审核 CHECKED 夏操云

ANGLES ±1° 版本 REV A 批准 APPROVE 赵亮亮