

Integrated PMIC with 4-Channel Synchronous Buck Converters, 8 LDOs, and MTP Non-Volatile Memory for Industrial and Automotive Applications

General Description

The RT5028F is a highly-integrated low-power high-performance analog SOC with PMIC in one single chip designed for industrial/automotive applications.

The RT5028F includes four synchronous step-down DC-DC converters and eight LDOs for system power.

The RT5028F also embeds one EEPROM (MTP) for setting sequence and timing etc.

Additionally, the RT5028F PMIC also includes one IRQ report.

Applications

- Industrial/Automotive

Features

- Input Voltage Operating Range is 3.15V to 5.5V
- Step-Down Regulator : V_{IN} Range is 3.15V to 5.5V
 - Max Current 2.4A/2A/1.6A/2A
 - Programmable Frequency from 500kHz to 2MHz
 - I²C Programmable Output Level
 - I²C Programmable Operation Mode (Force PWM or Auto PSM/PWM)
 - I²C Programmable Output Discharge Mode (Discharge or Floating)
- Linear Regulators : V_{IN} Range is 2.5V to 5.5V
 - Max Current 0.3A
 - I²C Programmable Output Level
- Embedded 32Bytes MTP for Factory Tuning
 - External MTP Pin for Write Protection
- Sequence can be Controlled by I²C or each EN pins Defined by MASK_GPIO Pin
- OT/UVP/VIN LV/POWRON Press Time Interrupt (IRQ)
 - I²C Control Interface : Support Fast Mode Up to 400kb/s
- RoHS Compliant and Halogen Free

Simplified Application Circuit

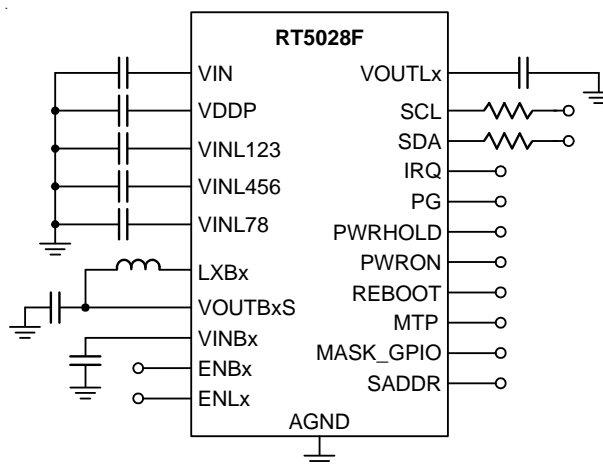

Ordering Information

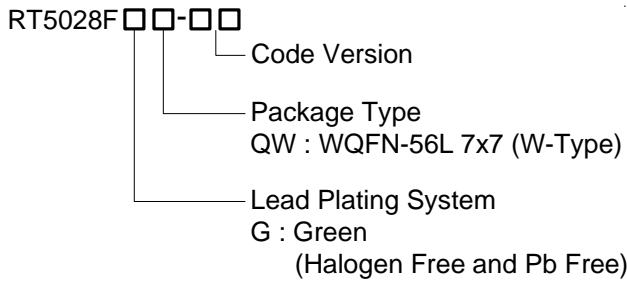

Note :

Richtek products are :

- ▶ RoHS compliant and compatible with the current requirements of IPC/JEDEC J-STD-020.
- ▶ Suitable for use in SnPb or Pb-free soldering processes.

Marking Information



RT5028FGQW : Product Number
YMDNN : Date Code

Pin Configuration

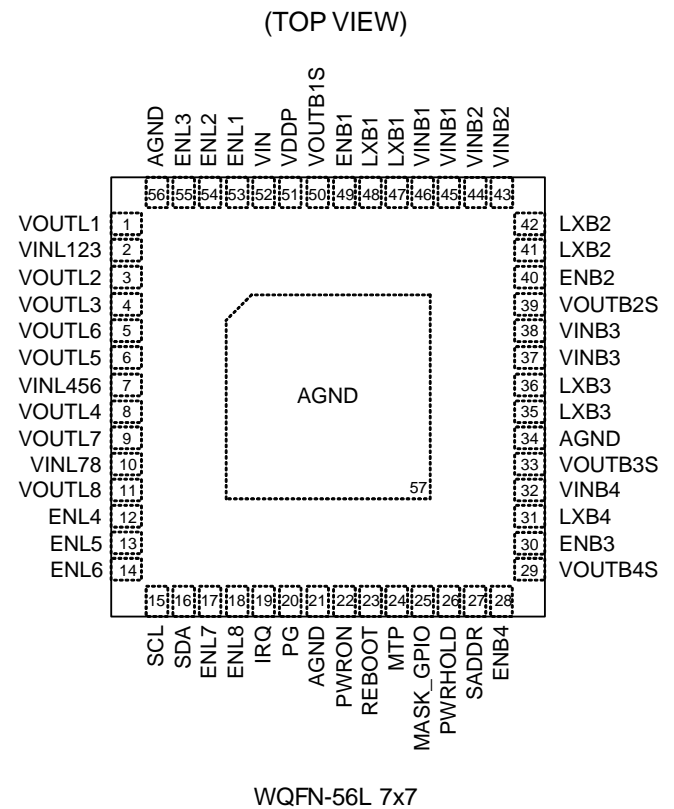

Functional Pin Description

Pin No.	Pin Name	Pin Function
1	VOUTL1	Output voltage regulation node for LDO1.
2	VINL123	Input power for LDO1, LDO2 and LDO3.
3	VOUTL2	Output voltage regulation node for LDO2.
4	VOUTL3	Output voltage regulation node for LDO3.
5	VOUTL6	Output voltage regulation node for LDO6.
6	VOUTL5	Output voltage regulation node for LDO5.
7	VINL456	Input power for LDO4, LDO5 and LDO6.
8	VOUTL4	Output voltage regulation node for LDO4.
9	VOUTL7	Output voltage regulation node for LDO7.
10	VINL78	Input power for LDO7 and LDO8.
11	VOUTL8	Output voltage regulation node for LDO8.
12	ENL4	Enable control input for LDO4.
13	ENL5	Enable control input for LDO5.
14	ENL6	Enable control input for LDO6.
15	SCL	Clock input for I ² C. Open-drain output.

Pin No.	Pin Name	Pin Function
16	SDA	Data input for I ² C. Open-drain output.
17	ENL7	Enable control input for LDO7.
18	ENL8	Enable control input for LDO8.
19	IRQ	Open-drain IRQ output node.
20	PG	Power good indicator.
21, 34, 56, 57 (Exposed Pad)	AGND	Analog ground. The exposed pad must be soldered to a large PCB and connected to AGND for maximum power dissipation.
22	PWRON	Manual power on.
23	REBOOT	System power reboot.
24	MTP	MTP write protection pin. Logic low is inhibited and logic high is permit to write.
25	MASK_GPIO	Select I ² C or EN pin for Bucks and LDOs. Connect a 100kΩ pull-low resistor. As MASK_GPIO is high, ignore all EN pins. As MASK_GPIO is low, EN pins and I ² C both can control. EN pins priority is higher than I ² C.
26	PWRHOLD	Power hold input.
27	SADDR	I ² C slave address.
28	ENB4	Enable control input for Buck4.
29	VOUTB4S	Output voltage regulation node for Buck4.
30	ENB3	Enable control input for Buck3.
31	LXB4	Internal switch node to output inductor connection for Buck4.
32	VINB4	Input power for Buck4.
33	VOUTB3S	Output voltage regulation node for Buck3.
35, 36	LXB3	Internal switch node to output inductor connection for Buck3.
37, 38	VINB3	Input power for Buck3.
39	VOUTB2S	Output voltage regulation node for Buck2.
40	ENB2	Enable control input for Buck2.
41, 42	LXB2	Internal switch node to output inductor connection for Buck2.
43, 44	VINB2	Input power for Buck2.
45, 46	VINB1	Input power for Buck1.
47, 48	LXB1	Internal switch node to output inductor connection for Buck1.
49	ENB1	Enable control input for Buck1.
50	VOUTB1S	Output voltage regulation node for Buck1
51	VDDP	Internal bias regulator voltage. External load on this pin is not allowed.
52	VIN	Input power for analog base.
53	ENL1	Enable control input for LDO1.
54	ENL2	Enable control input for LDO2.
55	ENL3	Enable control input for LDO3.

Functional Block Diagram

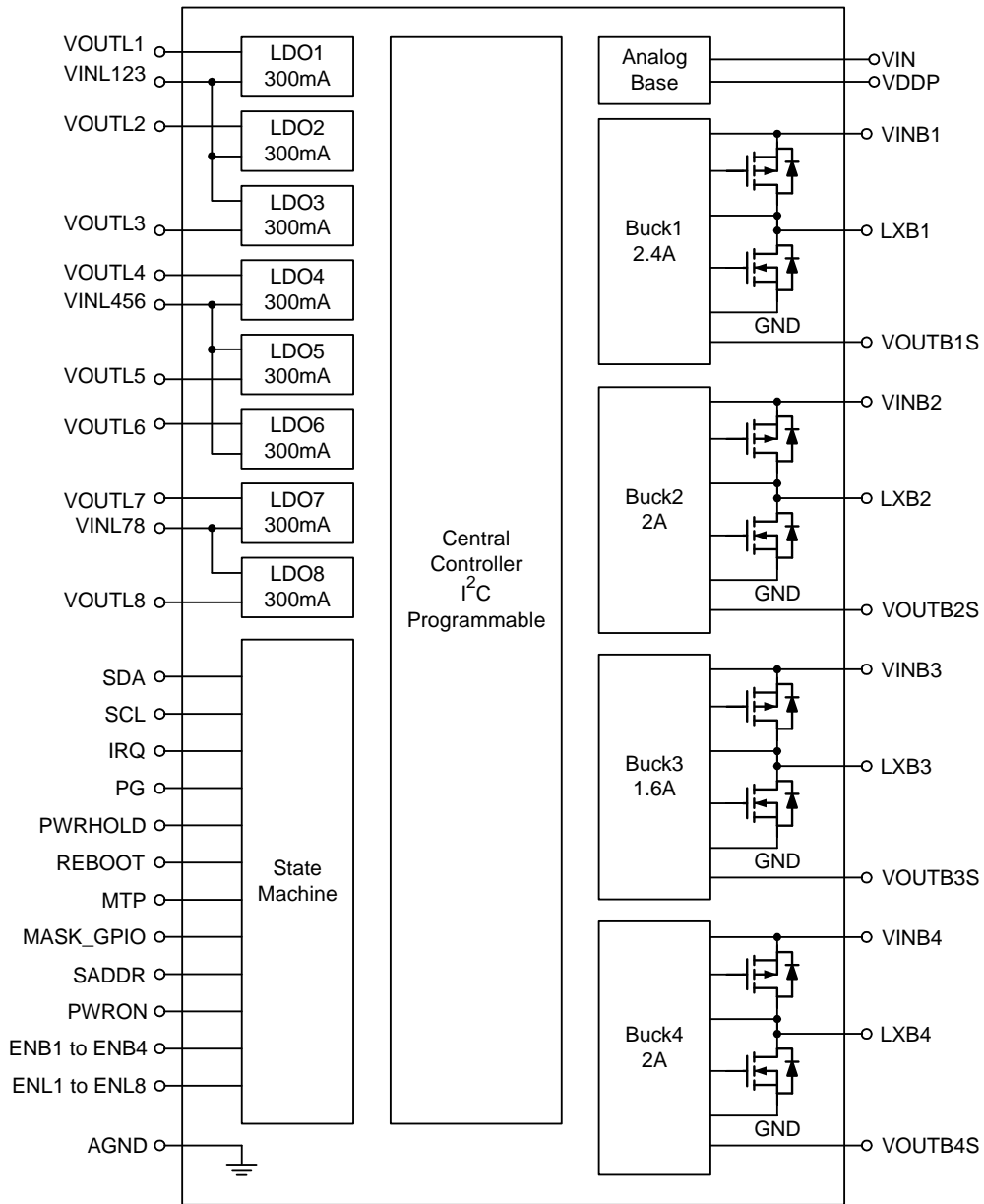

Absolute Maximum Ratings (Note 1)

- Analog Base Input Voltage, V_{IN} ----- -0.3V to 6V
- PMIC Input Voltage, $V_{INL123/456/78}$, $V_{INB1/2/3/4}$ ----- -0.3V to 6V
- PMIC Output Voltage, V_{OUTLx} , V_{OUTBxS} , $LXBx$ ----- -0.3V to 6V
- PMIC related Other Pins ----- -0.3V to 6V
- Power Dissipation, P_D @ $T_A = 25^\circ C$
 WQFN-56L 7x7 ----- 3.7W
- Package Thermal Resistance (Note 2)
 WQFN-56L 7x7, θ_{JA} ----- $27^\circ C/W$
 WQFN-56L 7x7, θ_{JC} ----- $7^\circ C/W$
- Junction Temperature ----- $150^\circ C$
- Lead Temperature (Soldering, 10 sec.) ----- $260^\circ C$
- Storage Temperature Range ----- $-65^\circ C$ to $150^\circ C$
- ESD Susceptibility (Note 3)
 HBM (Human Body Model) ----- 2kV

Recommended Operating Conditions (Note 4)

- Junction Temperature Range ----- $-40^\circ C$ to $125^\circ C$
- Ambient Temperature Range ----- $-40^\circ C$ to $85^\circ C$

Electrical Characteristics

($T_A = 25^\circ C$, $V_{IN} = 3.15V$ to $5.5V$ (Note 5, 6))

Parameter	Symbol	Test Conditions	Min	Typ	Max	Unit
AMR for V_{IN}			--	--	6	V
Operation Voltage of V_{IN}		As $f_{SW} > 1MHz$, $3.15V \leq V_{IN} \leq 5.5V$. If $f_{SW} \leq 1MHz$, $V_{IN} \geq 4V$.	3.15	--	5.5	V
PMIC						
Quiescent Current	I_{IN}	$V_{IN} = 5V$, LDOs, Bucks are ON with no load. Bucks operate in auto mode (Reg 0x06 = FFh)	350	700	950	μA
		$V_{IN} = 5V$, SCL = SDA = 0V, LDO and Bucks are OFF, Disable PMIC (Reg0x15[7] = 1)	5	30	60	
Warning for Die Temperature	OTW	Temperature 1	--	100	--	$^\circ C$
		Temperature 2	--	125	--	
Over-Temperature Protection	OTP		--	165	--	$^\circ C$
OTP and Warning Hysteresis			--	10	--	$^\circ C$
Input Pull-Low 100k Ω Resistor	R_{Low}	$V_{IN} = 5V$	70	115	160	k Ω

Parameter	Symbol	Test Conditions	Min	Typ	Max	Unit	
Buck1 to Buck4							
Input Voltage	V_{INB}		3.15	--	5.5	V	
Consumption Current	I_{VINB}	AUTO mode $I_{OUT} = 0mA$, each Buck	10	30	50	μA	
Output Voltage Accuracy	V_{OUTAcc}	$3.1V < V_{IN} < 5.5V$, $1mA < I_{OUT} < I_{MAX}$	-3	--	3	%	
Switching Frequency	f_{SW}	I ² C programmable	0.5	--	2.00	MHz	
Switching Frequency Accuracy		$1MHz < f_{SW}$	-10	--	10	%	
		$f_{SW} \leq 1MHz$	-20	--	20		
Peak Current Limit	OCP	Buck1	3.1	4.4	5.8	A	
		Buck2	2.8	4	5.2		
		Buck3	2.6	3.7	4.8		
		Buck4	2.8	4	5.2		
Under-Voltage Protection	UVP	V_{OUTB1S} to $V_{OUTB4S} < 0.66 \times (V_{OUT} \text{ target})$	56	66	76	%	
Maximum Output Current	I_{MAX}	Buck1	2.4	--	--	A	
		Buck2	2	--	--		
		Buck3	1.6	--	--		
		Buck4	2	--	--		
High-Side On-Resistance	R_{pon}	$V_{IN} = 3.7V$	50	150	250	$m\Omega$	
Low-Side On-Resistance	R_{non}	$V_{IN} = 3.7V$	40	110	160	$m\Omega$	
LDO1 to LDO8							
Input Voltage for VINL123/456/78	V_{INL}		2.5	--	5.5	V	
Output Voltage LDO123/78	V_{OUTL}	$3.1V \leq V_{IN} \leq 5.5V$, $50\mu A \leq I_{OUT} \leq I_{MAX}$	-3	--	3	%	
Output Voltage LDO456	V_{OUTL}	$3.1V \leq V_{IN} \leq 5.5V$, $50\mu A \leq I_{OUT} \leq I_{MAX}$	-3	--	3	%	
Output Current	I_{OUT}		300	--	--	mA	
Output Short Current	I_{sht}		330	450	600	mA	
Voltage Difference	$V_{IN} - V_{OUT}$	$V_{IN} > 3.1V$	$V_{IN} = V_{SET}$, $I_{OUT} = I_{OUTMAX}$	0.05	0.10	0.30	V
		$V_{IN} > 2.5V$		0.05	0.11	0.50	
Supply Current	I_{SS}	$I_{OUT} = 0mA$	10	50	75	μA	
Shutdown Current	I_{OFF}		0	1	2	μA	
Control Input Pin Electrical Characteristics							
Voltage Output Low	V_{OL}		--	--	0.4	V	
Input Voltage	High-Level	V_{IH}	1.5	--	--	V	
	Low-Level	V_{IL}	--	--	0.7		
PG Pin Electrical Characteristics							
Output Low Voltage PG		$I_{sink} = 1mA$, $V_{IN} = 3.15V$ to $5.5V$	--	--	0.2	V	
Output High Leakage PG		$V_{IN} = 3.15V$ to $5.5V$	-1	0	1	μA	

- Note 1.** Stresses beyond those listed under “Absolute Maximum Ratings” may cause permanent damage to the device. These are stress ratings only, and functional operation of the device at these or any other conditions beyond those indicated in the operational sections of the specifications is not implied. Exposure to absolute maximum rating conditions may affect device reliability.
- Note 2.** θ_{JA} is measured under natural convection (still air) at $T_A = 25^\circ\text{C}$ with the component mounted on a high effective-thermal-conductivity four-layer test board on a JEDEC 51-7 thermal measurement standard. θ_{JC} is measured at the exposed pad of the package.
- Note 3.** Devices are ESD sensitive. Handling precaution is recommended.
- Note 4.** The device is not guaranteed to function outside its operating conditions.
- Note 5.** Limits apply to the recommended operating temperature range of -40°C to 85°C , unless otherwise noted. Minimum and maximum limits are verified through test, design, or statistical correlation. Typical values represent the most likely parametric norm at $T_A = 25^\circ\text{C}$, and are provided for reference purposes only. Unless otherwise stated the following conditions apply : $V_{IN} = 3.15\text{V}$ to 5.5V .
- Note 6.** In applications where high power dissipation or poor package thermal resistance is present, the maximum ambient temperature may have to be derated. Maximum ambient temperature (T_{A-MAX}) is dependent on the maximum operating junction temperature ($T_{J-MAX} = 125^\circ\text{C}$), the maximum power dissipation of the device in the application (P_{D-MAX}), and the junction-to-ambient thermal resistance of the part/package in the application ($R_{\theta JA}$), as given by the following equation : $T_{A-MAX} = T_{J-MAX} - (R_{\theta JA} \times P_{D-MAX})$.

Typical Application Circuit

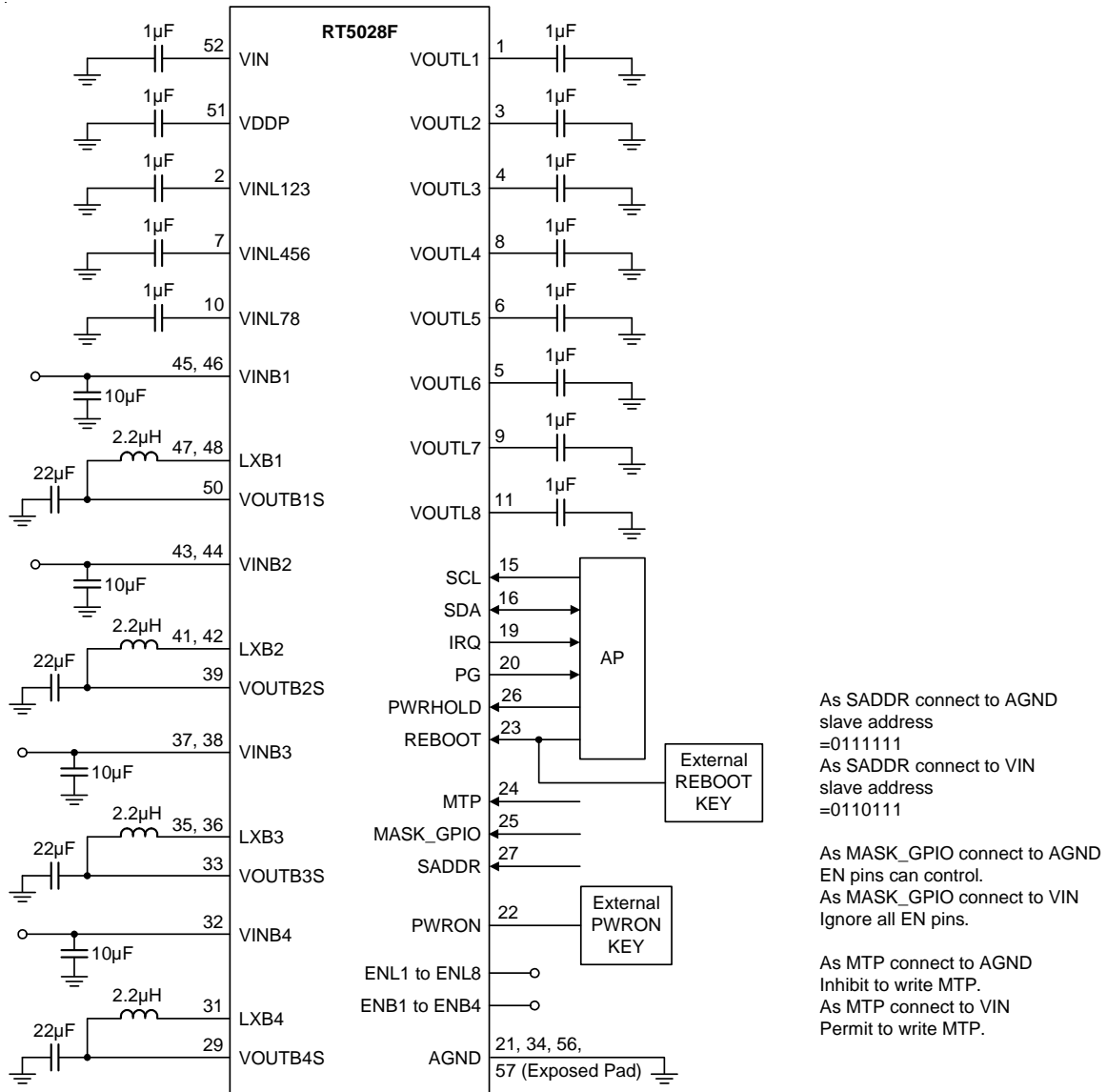

Suggested Components for Typical Application Circuit

Description	Part Number	Manufacturer
Inductor for Buck-2.2µH	MDWK4040T2R2MMV	TAIYO
	NRS5030T2R2NMGJV	TAIYO
C _{IN} for Buck-10µF	C1206X7R1E516DT	Murata
	EMK316AB7106KL-T	TAIYO
C _{OUT} for Buck-22µF	C1206X7R22E416DT	Murata
	JMK316AB7226KL-TR	TAIYO
C _{IN} /C _{OUT} for LDO/VIN/VDDP-1µF	C0603X7R1E216DT	Murata
	EMK107B7105KA-T	TAIYO

Typical Operating Characteristics

CH1 Buck Efficiency vs. Output Current

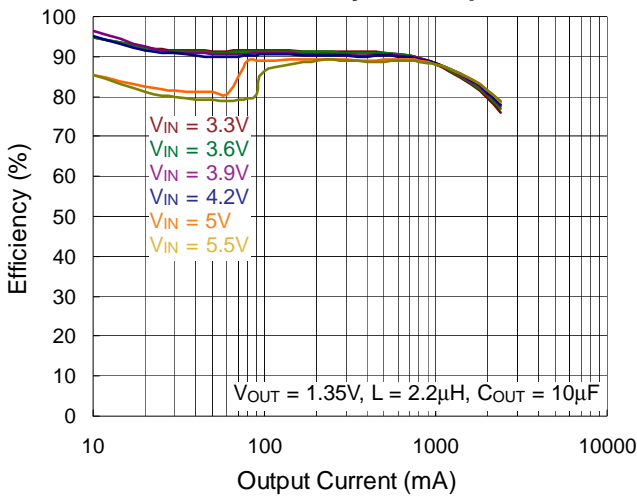

CH2 Buck Efficiency vs. Output Current

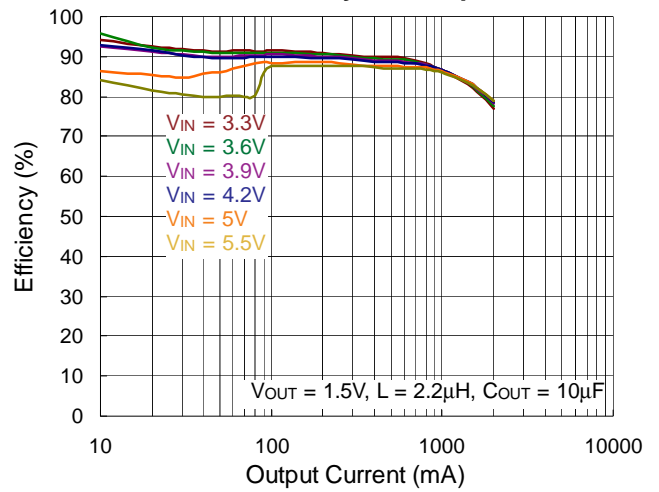

CH3 Buck Efficiency vs. Output Current

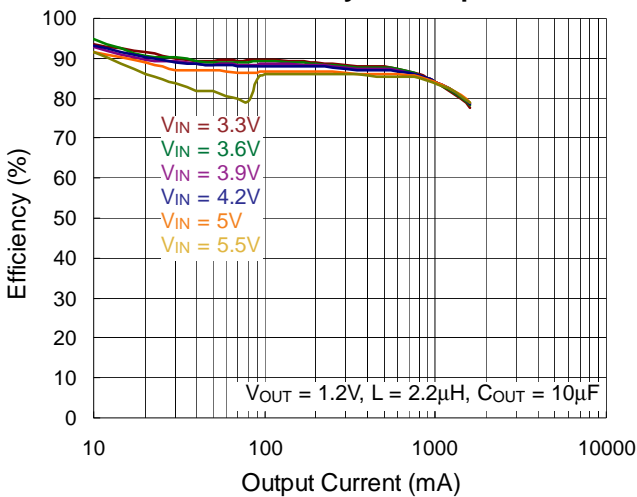

CH4 Buck Efficiency vs. Output Current

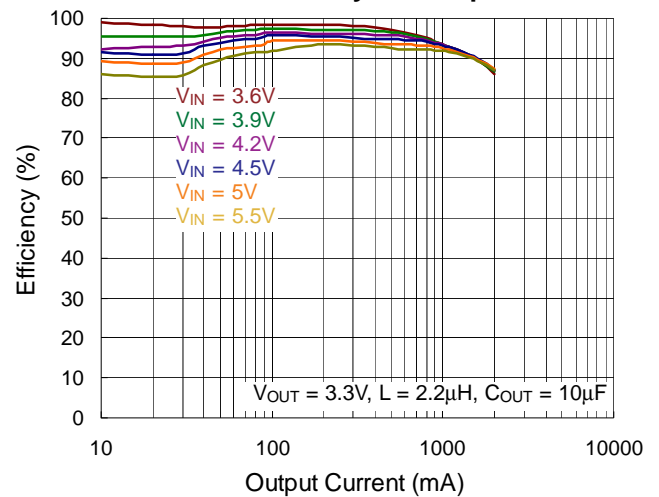

CH1 Buck Output Voltage vs. Output Current

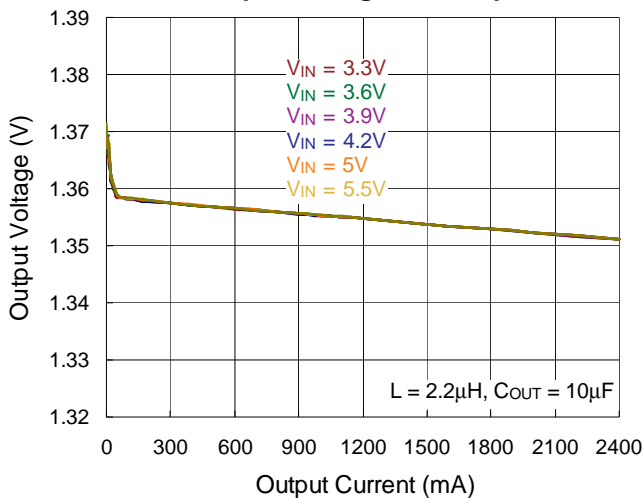

CH2 Buck Output Voltage vs. Output Current

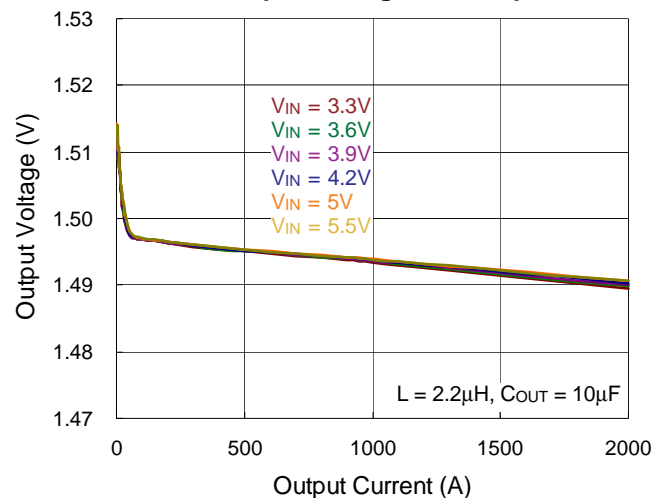

CH3 Buck Output Voltage vs. Output Current

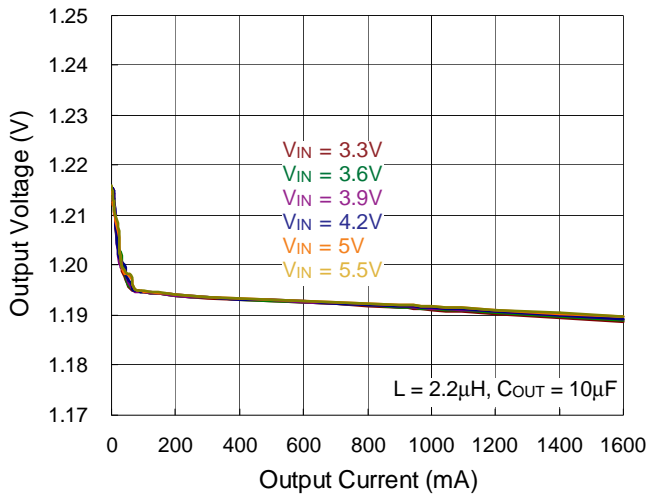

CH4 Buck Output Voltage vs. Output Current

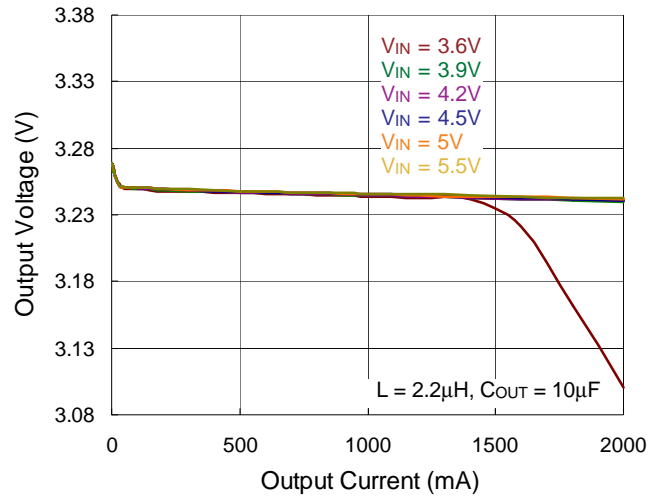

CH1 Buck Output Voltage vs. Input Voltage

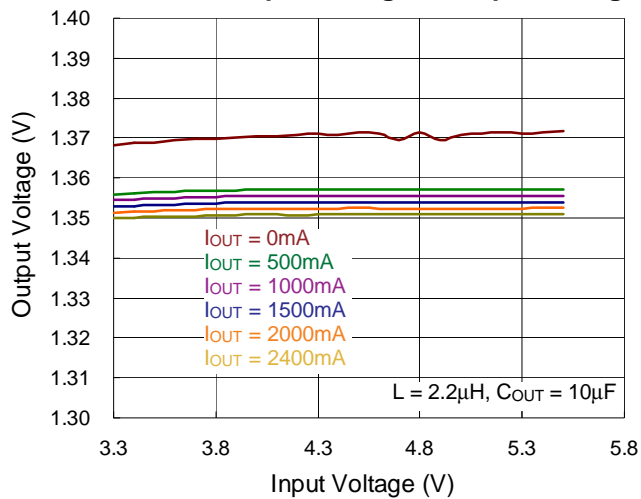

CH2 Buck Output Voltage vs. Input Voltage

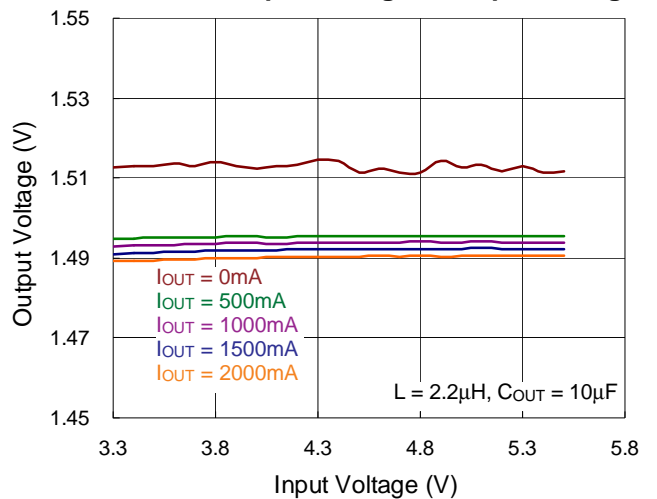

CH3 Buck Output Voltage vs. Input Voltage

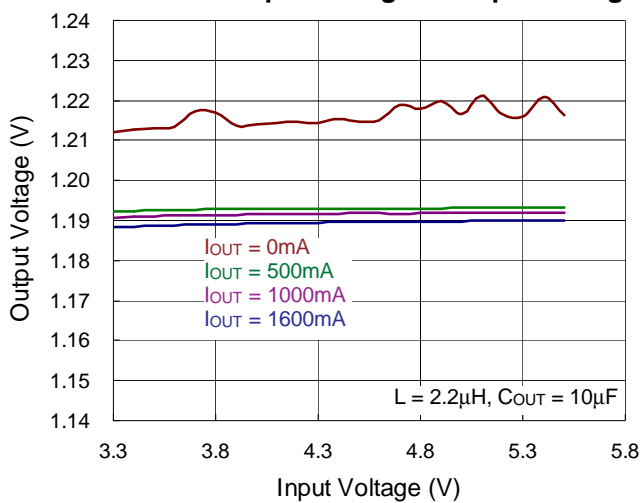

CH4 Buck Output Voltage vs. Input Voltage

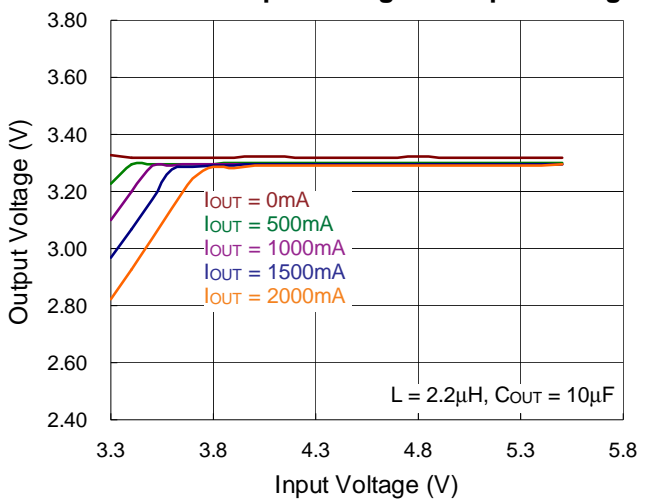

LDO2 Output Voltage vs. Output Current

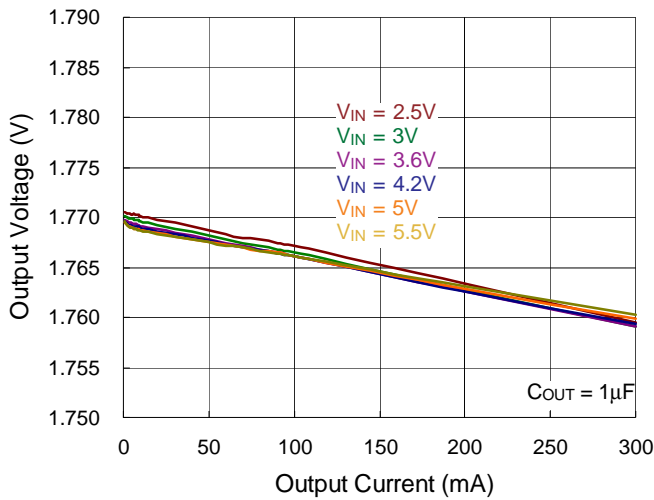

LDO5 Output Voltage vs. Output Current

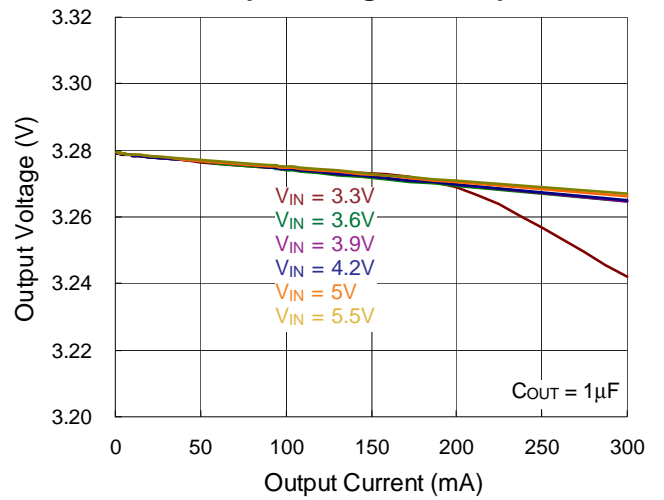

LDO7 Output Voltage vs. Output Current

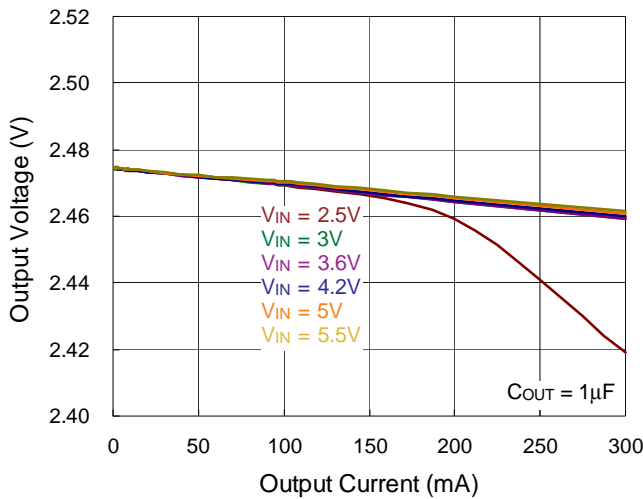

LDO2 Output Voltage vs. Input Voltage

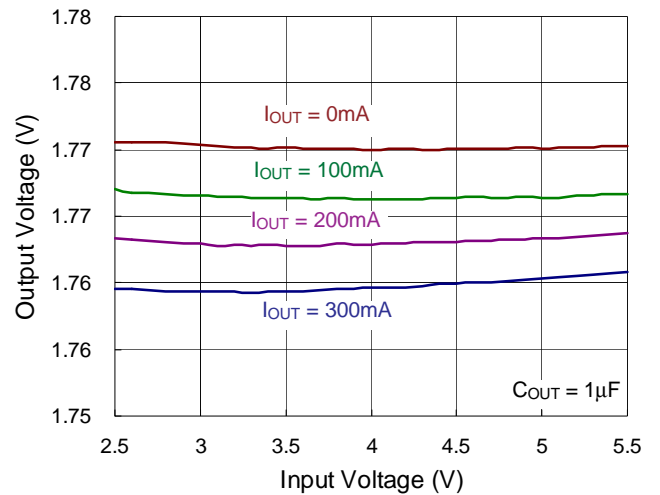

LDO5 Output Voltage vs. Input Voltage

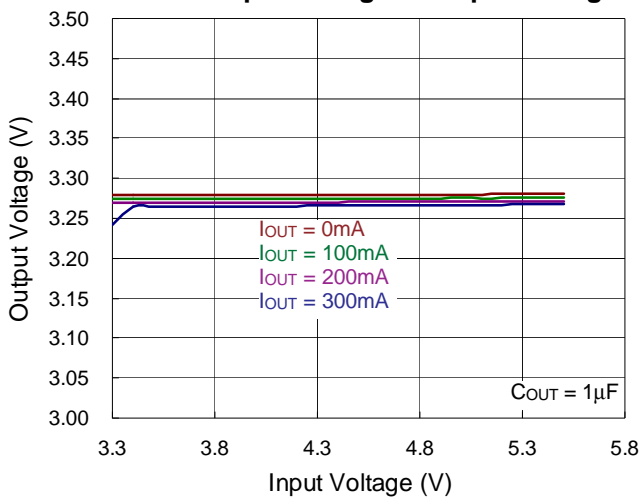

LDO7 Output Voltage vs. Input Voltage

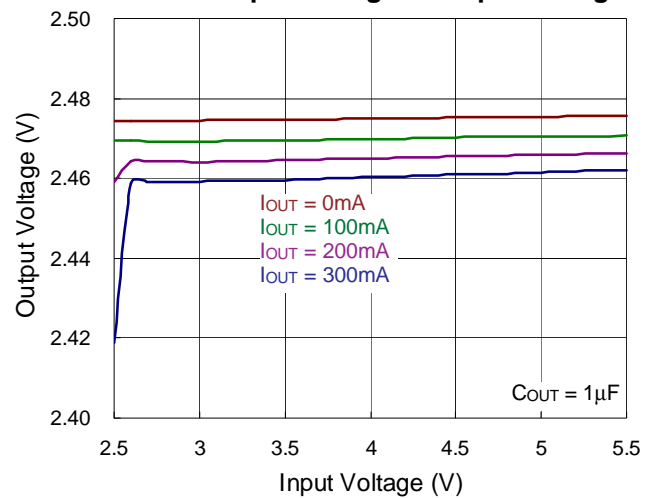

Application Information

The RT5028F is a highly-integrated solution for automotive system including PMIC and memory system. The RT5028F application mechanism and I²C compatible interface are introduced in later sections. The system's slave address is 0110111 (As SADDR = high) or 0111111 (As SADDR = low).

PMIC - Power management system provides 8 low dropout linear regulator and 4 high efficiency synchronous step-down DC-DC converters. Power-On and Power-Off sequences are control by PWRON and REBOOT input

pins. Detail time sequence control is described in Power ON/OFF diagram. The I²C interface can program individual regulator output voltage as well as on/off control and voltage setting.

I²C Interface Timing Diagram

The RT5028F acts as an I²C -bus slave. The I²C-bus master configures the settings for all function blocks by sending command bytes to the RT5028F via the 2-wire I²C-bus. The I²C timing diagrams are list in the following.

Parameter	Symbol	Test Conditions	Min	Typ	Max	Unit
I²C Interface Electrical Characteristics						
SDA, SCLK Input High Level Threshold			1.5	--	--	V
SDA, SCLK Input Low Level Threshold			--	--	0.4	V
SCLK Clock Rate	f _{SCL}		--	--	400	kHz
Hold Time (Repeated) START Condition. After this period, the first clock pulse is generated	t _{HD;STA}		0.6	--	--	μs
LOW Period of the SCL Clock	t _{LOW}		1.3	--	--	μs
HIGH Period of the SCL Clock	t _{HIGH}		0.6	--	--	μs
Set-Up Time for a Repeated START Condition	t _{SU;STA}		0.6	--	--	μs
Data Hold Time	t _{HD;DAT}		0	--	0.9	μs
Data Set-Up Time	t _{SU;DAT}		100	--	--	ns
Set-Up Time for STOP Condition	t _{SU;STO}		0.6	--	--	μs
Bus Free Time Between a STOP and START Condition	t _{BUF}		1.3	--	--	μs
Rise Time of Both SDA and SCL Signals	t _R		20	--	300	ns
Fall Time of Both SDA and SCL Signals	t _F		20	--	300	ns
SDA and SCL Output Low Sink Current	I _{OL}	SDA or SCL voltage = 0.4V	2	--	--	mA

Read and Write Function

Read single byte of data from Register

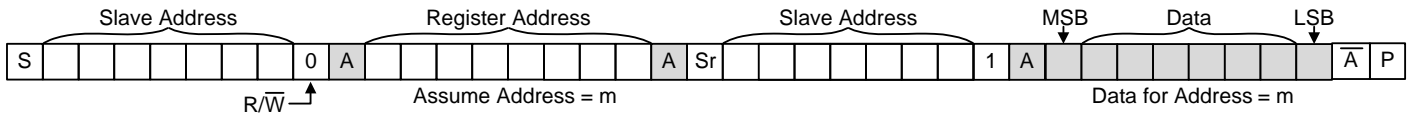

Read N bytes of data from Registers

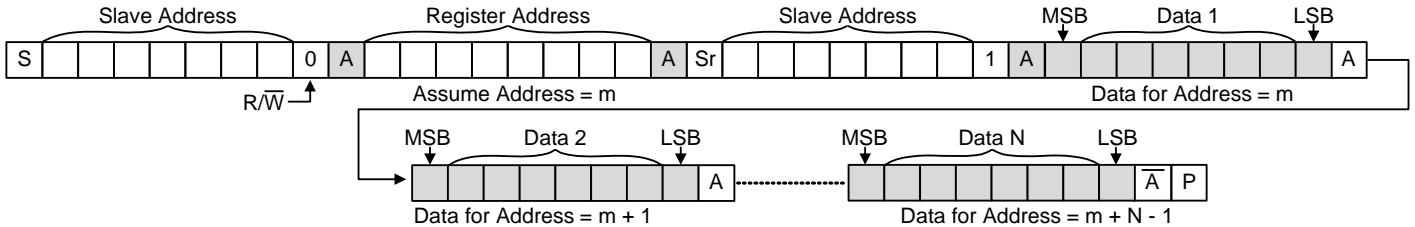

Write single byte of data to Register

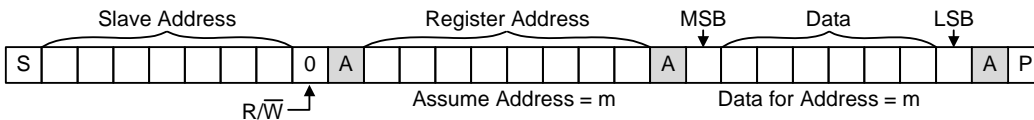

Write N bytes of data to Registers

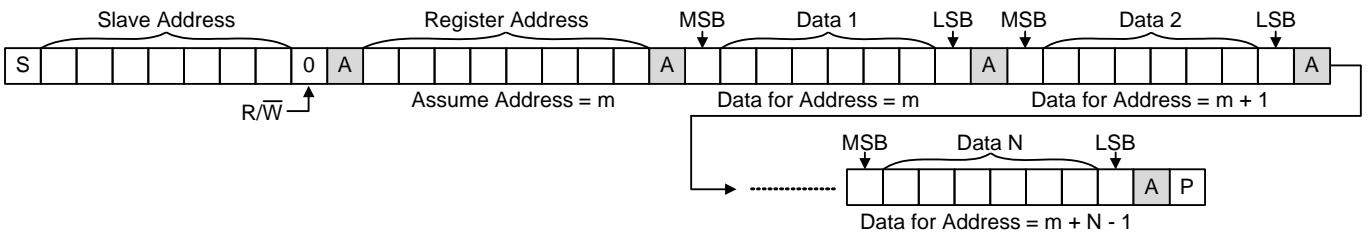

□ Driven by Master, ■ Driven by Slave, □ P Stop, □ S Start, □ Sr Repeat Start

I²C Waveform Information

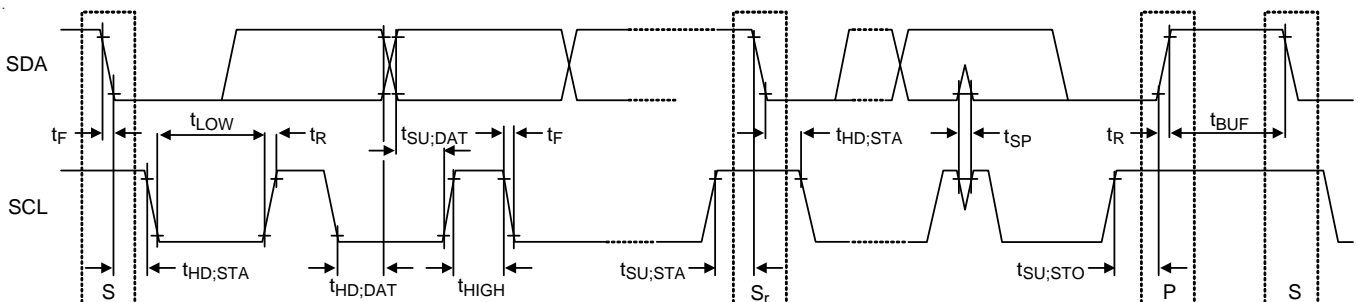

PMIC

Power Channels Control Methodology

When VIN power Good or PWRON event occurs, the PMIC will follow the power on sequence to turn on channels.

During normal operation, users can use the REBOOT pin rapid to restart PMIC. Another PWROFF event, OTP, VIN OVP, VIN UVLO, UVP or PWROFF occurs, PMIC will execute the power off. The power on/off mode control is shown in Figure 1 and Table 1.

VIN Over-Voltage Protection

The device has a built-in OVP circuit which monitors the input voltage. If the voltage exceeds the OVP threshold

(typ value = 5.95V), the device stops operating. As soon as the voltage drops below the low threshold (typ value = 5.65V), the device starts to operate again. Therefore, over-voltage protection is implemented to prevent the input voltage from exceeding critical values to damage the device.

Base on ISO 7637 and 16750 test case, if VIN vary violently, the device will trigger UVP or OVP (VIN rising up slew rate should be less than 5V/1ms) and then stops operating. The device needs to do reset by REBOOT pin or VIN (VIN < 1.7V) to resume operation.

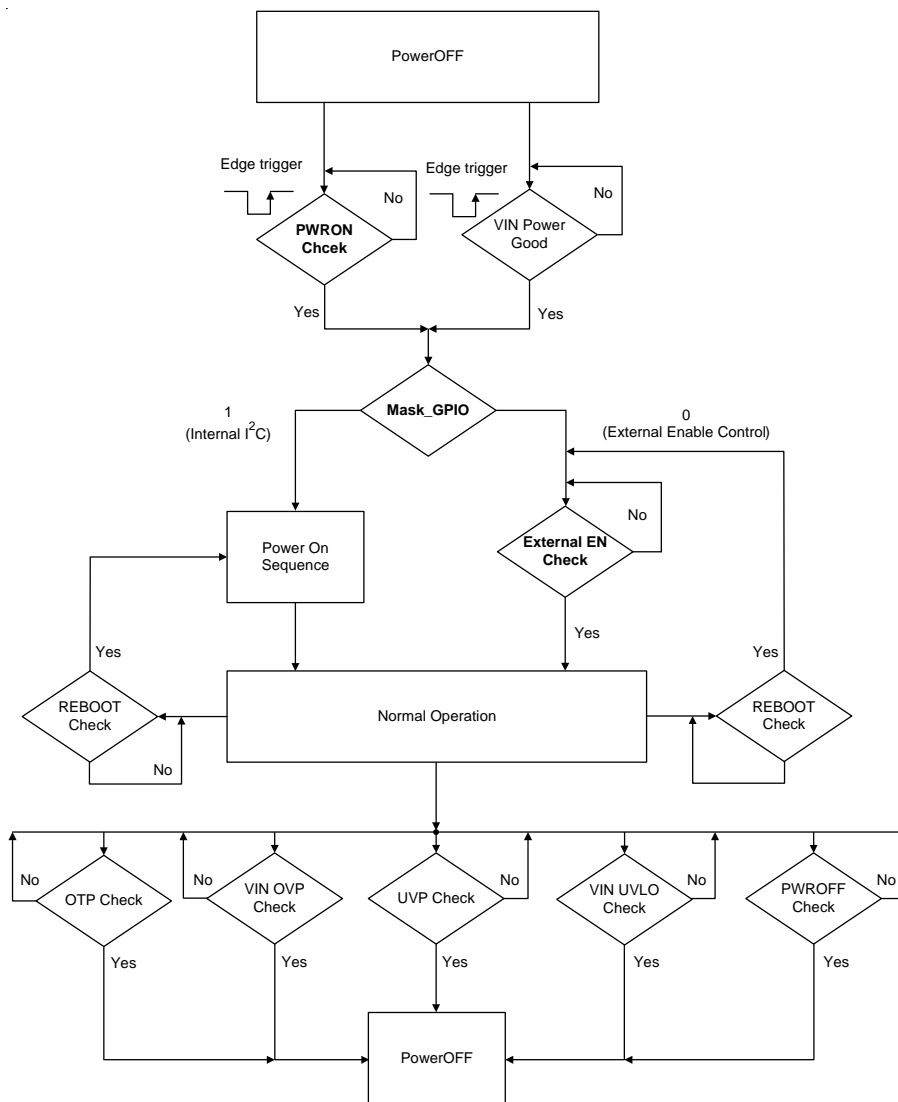

Figure 1. Power ON/OFF Flow Chart

Table 1. Protection List

Function	Protection Type	Threshold (Typical Value)	Deglintch/Delay Time	Protection Method	Reset Method (Typical Value)
VIN	POR	VIN < 1.7V	2μs	Disable all channels	VIN > 2V
	UVLO	VIN < VOFF setting	32μs	Disable all channels (Option)	VIN > VOFF setting + 0.4V 1. Reset by Reboot pin 2. VIN reset (VIN < 1.7V)
	OVP	VIN > 5.95V	No delay	Disable all channels	VIN < 5.65V 1. Reset by Reboot pin 2. VIN reset (VIN < 1.7V)
Buck1 to Buck4	OCP, 0x16 [7:4] = 0	PMOS current > OCP value	No delay	Disable channel	1. Re-enable by I ² C EN bit. 2. Reset by Reboot pin
	OCP, 0x16 [7:4] = 1	PMOS current > OCP value	Control by 0x15 [5:4] SHDN_DLYTIME	Disable all channels	1. Reset by PWRON pin 2. VIN reset (VIN < 1.7V)
	VOUT UVP	VOUT < 0.66 x (VOUT Target)	No delay	Disable channel (Option)	1. Re-enable by I ² C EN bit. 2. Reset by Reboot pin. 3. VIN reset (VIN < 1.7V)
LDO1 to LDO8	Current Limit	PMOS current > OCP value	No delay	Current Limit	Hiccup Until fail event to be dissolved
Thermal	Thermal shutdown	Temperature > 165°C	No delay	Disable all channels (Option)	Temperature < 155°C 1. Reset by PWRON pin. 2. VIN reset (VIN < 1.7V)

PMIC - POWER ON/OFF Setting

The circuit setting for communication between the RT5028F and AP is showed as below.

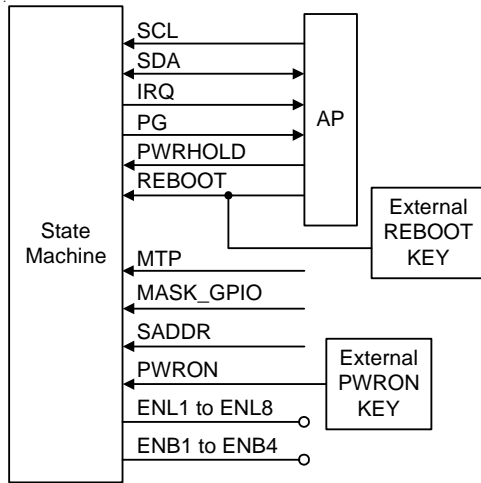

As SADDR connect to AGND
slave address
=0111111
As SADDR connect to VIN
slave address
=0110111

As MASK_GPIO connect to AGND
EN pins can control.
As MASK_GPIO connect to VIN
Ignore all EN pins.

As MTP connect to AGND
Inhibit to write MTP.
As MTP connect to VIN
Permit to write MTP.

PG Pin

The PG comparator features an open drain output. The PG pin pull high to input voltage with 10kΩ which slew rate define as follow.

PG Rising Slew Rate

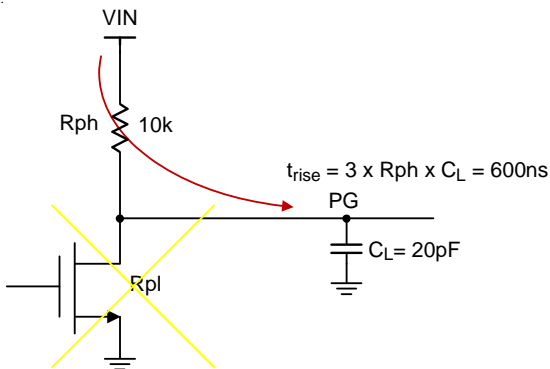

PG Falling Slew Rate

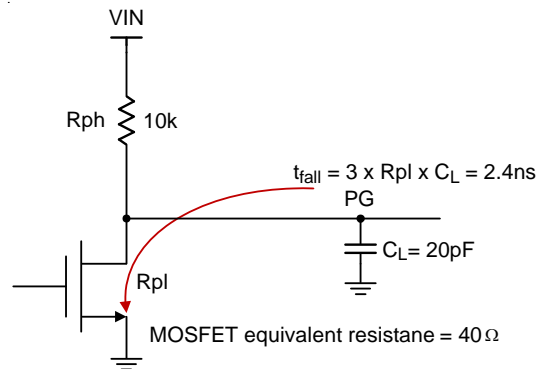

GPIO Pin Pull-Up/Down Defined

Pin No.	Pin Name	GPIO Pin Pull-Up/Down Defined	Resistor
12	ENL4	Internal 100kΩ pull low resistor	Internal
13	ENL5	Internal 100kΩ pull low resistor	Internal
14	ENL6	Internal 100kΩ pull low resistor	Internal
15	SCL	Open drain, need to connect pull up resistor with range from 2.2kΩ to 10kΩ	External
16	SDA	Open drain, need to connect pull up resistor with range from 2.2kΩ to 10kΩ	External
17	ENL7	Internal 100kΩ pull low resistor	Internal
18	ENL8	Internal 100kΩ pull low resistor	Internal
22	PWRON	Internal 100kΩ pull up resistor	Internal
23	REBOOT	Internal 100kΩ pull low resistor	Internal
24	MTP	Internal 100kΩ pull low resistor	Internal
26	PWRHOLD	Internal 100kΩ pull low resistor	Internal
27	SADDR	Internal 100kΩ pull low resistor	Internal
28	ENB4	Internal 100kΩ pull low resistor	Internal
30	ENB3	Internal 100kΩ pull low resistor	Internal
40	ENB2	Internal 100kΩ pull low resistor	Internal
49	ENB1	Internal 100kΩ pull low resistor	Internal
53	ENL1	Internal 100kΩ pull low resistor	Internal
54	ENL2	Internal 100kΩ pull low resistor	Internal
55	ENL3	Internal 100kΩ pull low resistor	Internal

Power Hold Function

When the "PWRHOLD" signal does not come during THOLD time, the RT5028F will do shutdown sequence.

If users want to disable power hold function, set "DisTHOLD" bit in I²C register 0x10 bit[0] to disable this function. In the timing diagram below, the "THOLD" and "PG_DLY" can be set by MTP program.

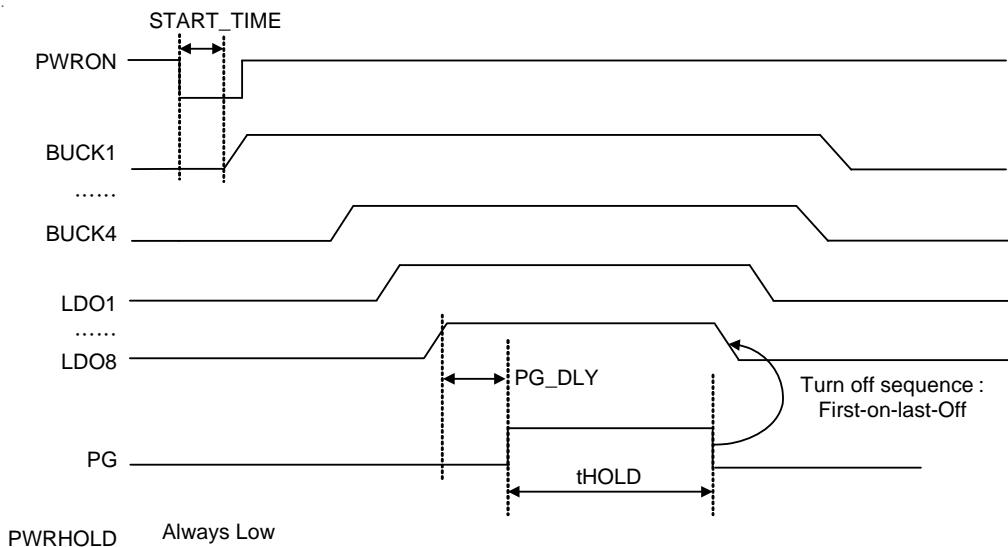

When AP sends the "PWRHOLD" signal during THOLD time, the RT5028F will keep power-on.

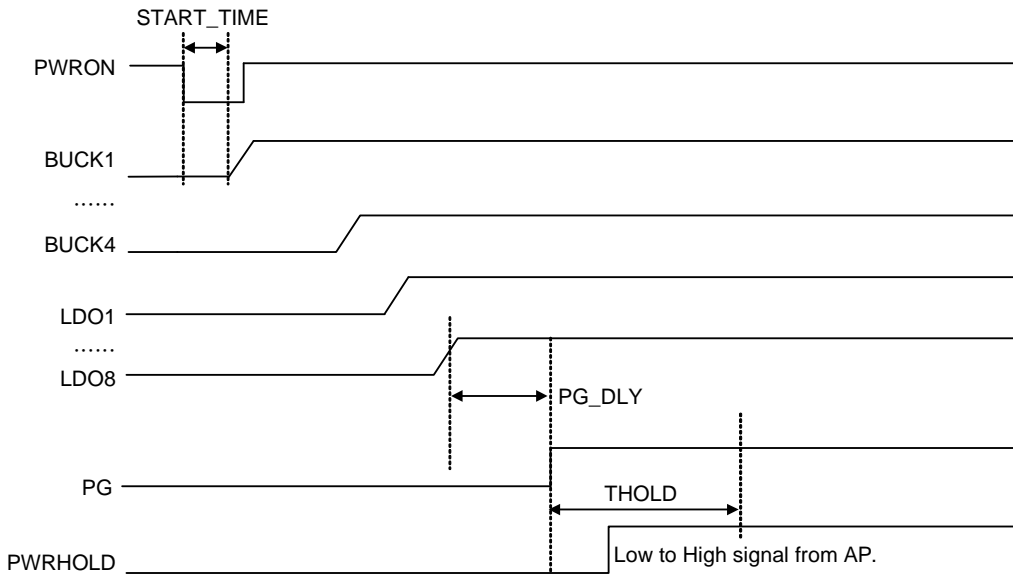

Timing Based ON/OFF Sequence (PWRON_NORMOFF_EN, Reg0x15[0] = 1)

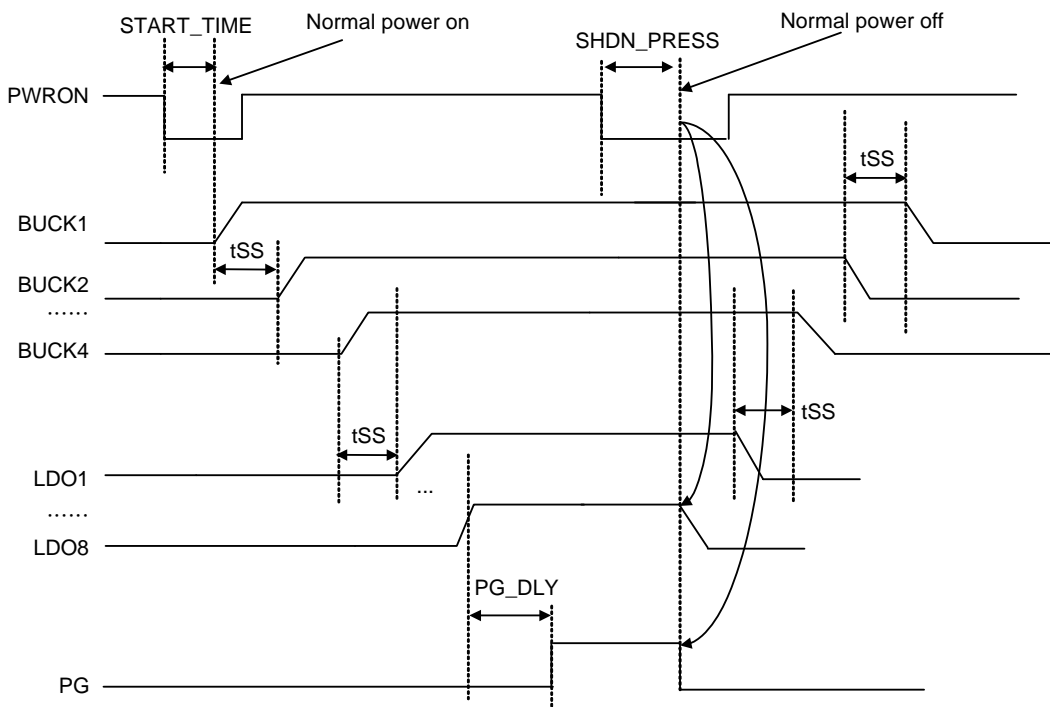

Level Based ON/OFF Sequence (PWRON_NORMOFF_EN, Reg0x15[0] = 1)

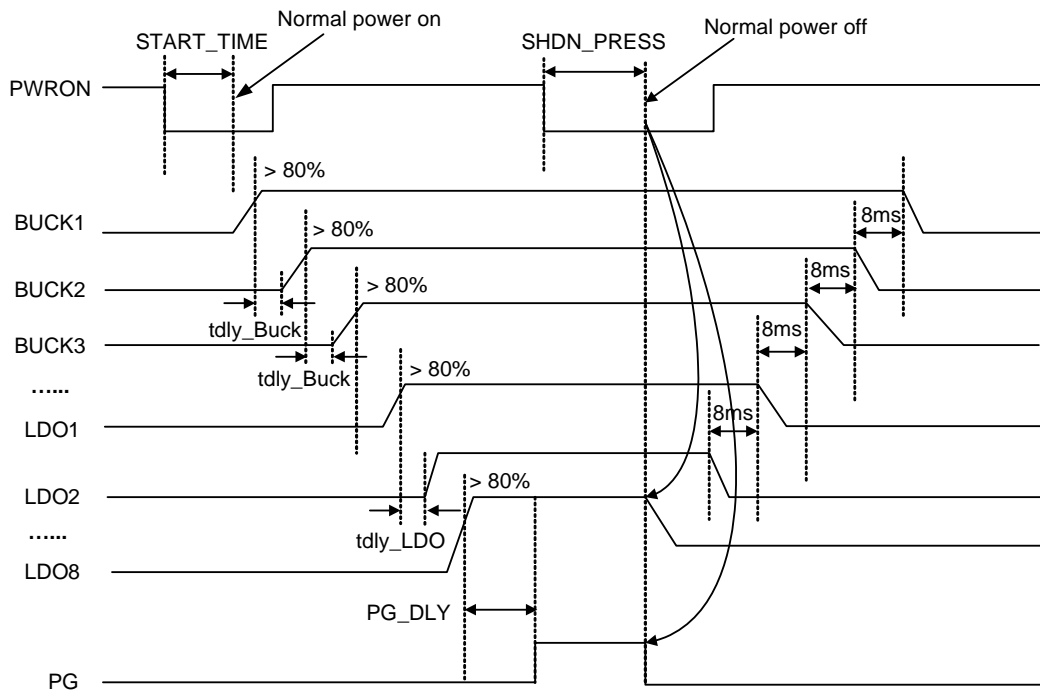

Note.

Sequence : BUCK1→BUCK2→BUCK3→BUCK4→LDO1→LDO2→LDO3→LDO4→LDO5→LDO6→LDO7→LDO8

tdly_Buck : $192 \times (1/fsw) + 40\mu s \pm 35\%$

tdly_LDO : $110\mu s \pm 20\%$ (If previous one channel is Buck, additional delay time $32 \times (1/fsw)$ need to be added to tdy_LDO.)

Abnormal OFF (OTP, Buck 1/2/3/4 UVP)

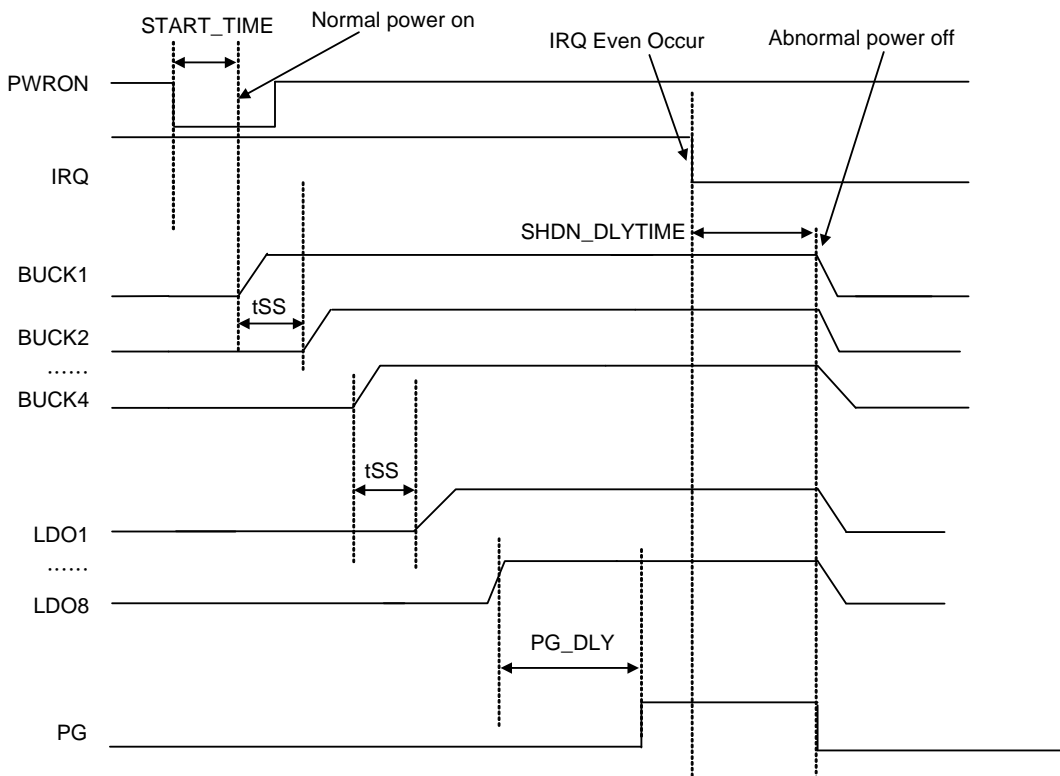

Based ON/OFF Sequence by VIN (VINLV_ENSHDN, Reg0x16[1] = 0)

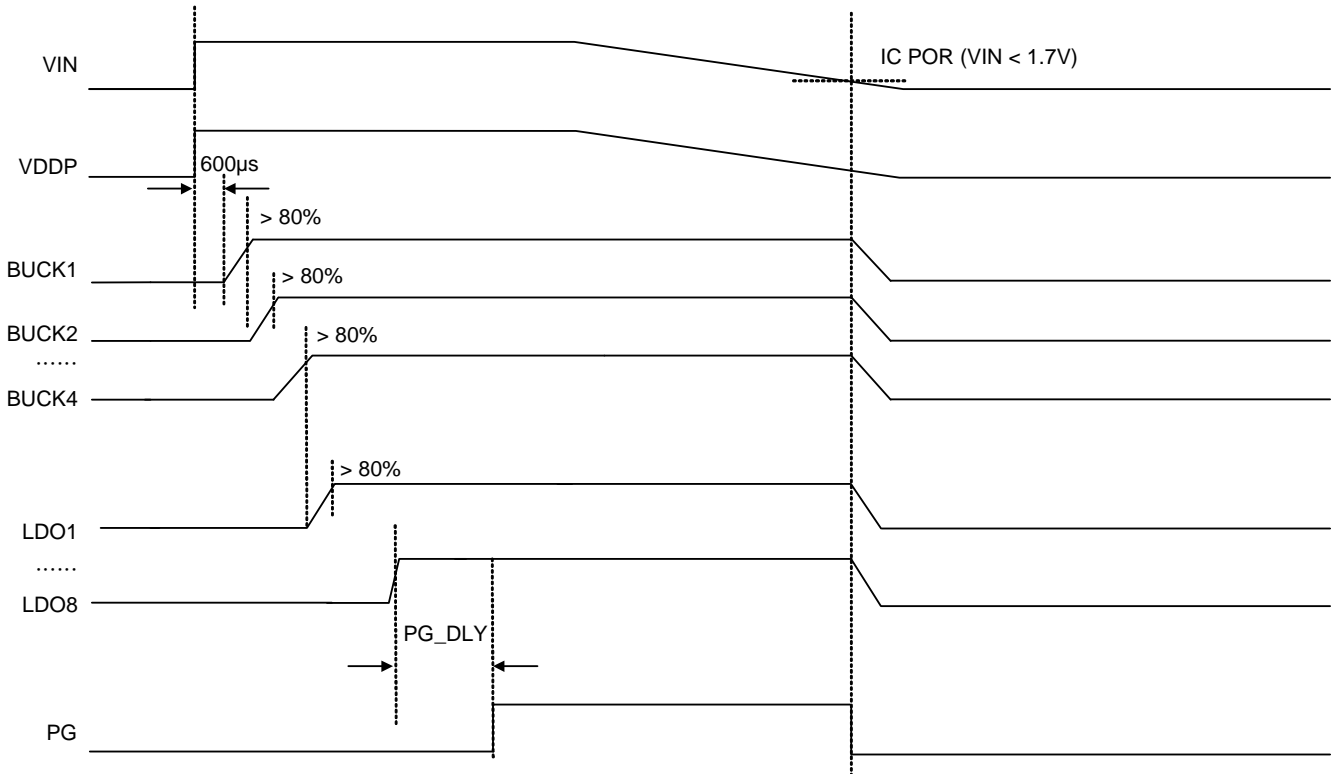

(VINLV_ENSHDN, Reg0x16[1] = 1; VINLV_SEQ_EN, Reg0x16[0] = 1)

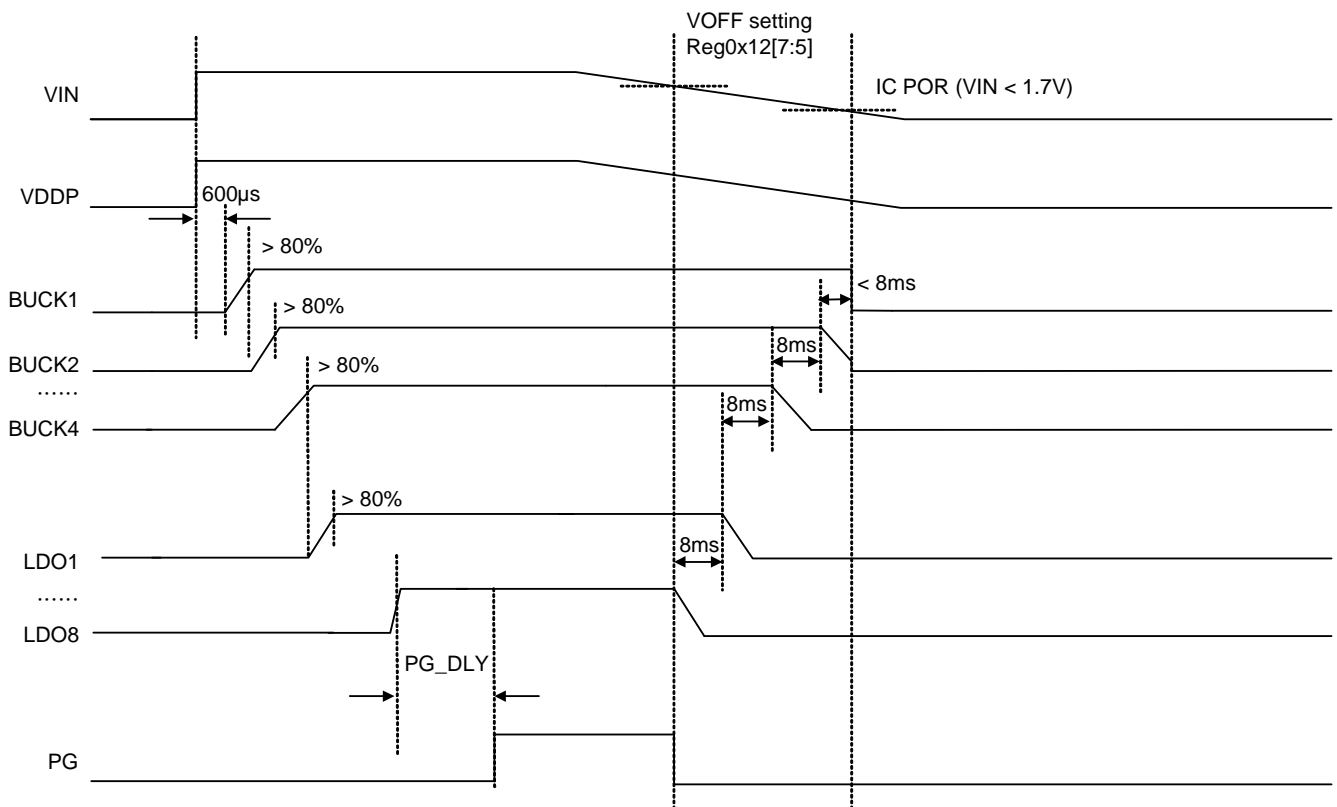

PMU On/Off Sequence Setting

In the RT5028F, users can set the power on/off sequence and output voltage by I²C register 0x01 to 0x04 for Buck output voltage, 0x07 to 0x0E for LDO output voltage and 0x2C to 0x32 for startup sequence setting.

Synchronous Step-Down DC-DC Converter

Four current mode synchronous step-down DC-DC converters operate with internal power MOSFETs and compensation network. These channels supply the power core chip of portable system. They can be operated at 100% maximum duty cycle to extend battery operating voltage range. When the input voltage is close to the output voltage, the converter enters low dropout mode with low output ripple. The operating frequency range of step-down converter is 0.5MHz to 2MHz.

Four step-down converters have RAMP control function as the following diagram.

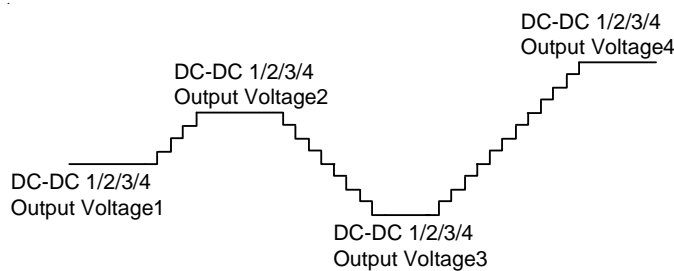

Input and Output Capacitors Selection

The RT5028F is designed to work with low ESR ceramic capacitors. The *effective* value of these capacitors is defined as the actual capacitance under voltage bias and temperature. All ceramic capacitors have a large voltage coefficient, in addition to normal tolerances and temperature coefficients. Under D.C. bias, the capacitance value drops considerably. Larger case sizes or higher voltage capacitors are better in this regard. To help mitigate these effects, multiple small capacitors can be used in parallel to bring the minimum *effective* capacitance up to the desired value.

The input capacitance, C_{IN}, is needed to filter the trapezoidal current at the source of the top MOSFET. A low ESR input capacitor with larger ripple current rating should be used for the maximum RMS current. RMS current is given by :

$$I_{RMS} = I_{OUT(MAX)} \times \frac{V_{OUT}}{V_{IN}} \times \sqrt{\frac{V_{IN}}{V_{OUT}} - 1}$$

This formula has a maximum at V_{IN} = 2V_{OUT}, where I_{RMS} = I_{OUT} / 2. This simple worst case condition is commonly used for design because even significant deviations do not offer much relief. Note that ripple current ratings from capacitor manufacturers are often based on only 2000 hours of life, which makes it advisable to either further derate the capacitor or choose a capacitor rated at a higher temperature than required. Several capacitors may also be placed in parallel to meet size or height requirements in the design. The selection of C_{OUT} is determined by the effective series resistance (ESR) that is required to minimize voltage ripple, load step transients, and the amount of bulk capacitance that is necessary to ensure that the control loop is stable. Loop stability can be examined by viewing the load transient response as described in a later section. The output ripple, ΔV_{OUT}, is determined by :

$$\Delta V_{OUT} \leq \Delta I_L \left[ESR + \frac{1}{8 \times f_{SW} \times C_{OUT}} \right]$$

The output ripple is highest at maximum input voltage since DIL increases with input voltage. Multiple capacitors placed in parallel may be needed to meet the ESR and RMS current handling requirements. Dry tantalum, special polymer, aluminum electrolytic and ceramic capacitors are all available in surface mount packages. Special polymer capacitors offer very low ESR but have lower capacitance density than other types. Tantalum capacitors have the highest capacitance density but it is important to only use types that have been surge tested for use in switching power supplies. Aluminum electrolytic capacitors have significantly higher ESR but can be used in cost-sensitive applications provided that consideration is given to ripple current ratings and long-term reliability. Ceramic capacitors have excellent low ESR characteristics but can have a high voltage coefficient and audible piezoelectric effects. The high Q of ceramic capacitors with trace inductance can also lead to significant ringing.

Using Ceramic Input and Output Capacitors

Higher values, lower cost ceramic capacitors are now becoming available in smaller case sizes. Their high ripple current, high voltage rating and low ESR make them ideal for switching regulator applications. However, care must be taken when these capacitors are used at the input and output. When a ceramic capacitor is used at the input and the power is supplied by a wall adapter through long wires, a load step at the output can induce ringing at the input, V_{IN} . At best, this ringing can couple to the output and be mistaken as loop instability. At worst, a sudden inrush of current through the long wires can potentially cause a voltage spike at V_{IN} large enough to damage the part. Page 8 shows the nominal values of input/output capacitance recommended for the RT5028F.

Inductor Selection

For a given input and output voltage, the inductor value and operating frequency determine the ripple current. The ripple current ΔI_L increases with higher V_{IN} and decreases with higher inductance :

$$\Delta I_L = \left[\frac{V_{OUT}}{f_{OSC} \times L} \right] \times \left[1 - \frac{V_{OUT}}{V_{IN}} \right]$$

Having a lower ripple current reduces the ESR losses in the output capacitors and the output voltage ripple. Highest efficiency operation is achieved at low frequency with small ripple current. This, however, requires a large inductor. A reasonable starting point for selecting the ripple current is $\Delta I_L = 0.4 (I_{MAX})$. The largest ripple current occurs at the highest V_{IN} . To guarantee that the ripple current stays below a specified maximum, the inductor value should be chosen according to the following equation :

$$L = \left[\frac{V_{OUT}}{f_{OSC} \times \Delta I_L(MAX)} \right] \times \left[1 - \frac{V_{OUT}}{V_{IN(MAX)}} \right]$$

Inductor Core Selection

Once the value for L is known, the type of inductor must be selected. High efficiency converters generally cannot afford the core loss found in low cost powdered iron cores, forcing the use of more expensive ferrite or permalloy cores. Actual core loss is independent of core size for a fixed inductor value but it is very dependent on the inductance

selected. As the inductance increases, core losses decrease. However, increased inductance requires more turns of wire and therefore copper losses will increase.

Ferrite designs have very low core losses and are preferred at high switching frequencies, so design goals can concentrate on copper loss and preventing saturation.

Ferrite core material saturates "hard" which means that inductance collapses abruptly when the peak design current is exceeded.

This results in an abrupt increase in inductor ripple current and consequent output voltage ripple.

Do not allow the core to saturate!

Different core materials and shapes will change the size/current and price/current relationship of an inductor. Toroid or shielded pot cores in ferrite or permalloy materials are small and don't radiate energy but generally cost more than powdered iron core inductors with similar characteristics. The choice of which style inductor to use mainly depend on the price vs. size requirements and any radiated field/EMI requirements.

REBOOT Function

As the REBOOT pin is set from low to high, the REBOOT function will be active. The REBOOT's FSM is shown as below. It concludes 100ms de-bouncing time and delay1/delay2 power off delay time.

Table 2. REBOOT Input Control Setting

	Description	Default
delayed2	00 : 100ms 10 : 1s	Option
delayed1	01 : 500ms 11 : 2s	Option
Action	delayed1 power-off then delayed2 power-on PMIC	

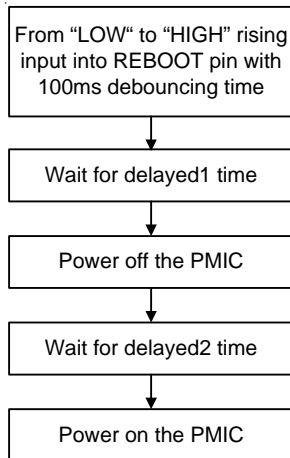

IRQ Table

We summarize all IRQ items in the register table. All IRQ_status registers are implemented as reset after read. If IRQ_enable bit is Low, the IRQ_status bit will not update status. IRQ_enable will mask IRQ_status to trigger IRQ_PMIC Low, so the system can decide which interrupt is necessary.

Waveform - (when the other IRQ_status are low)

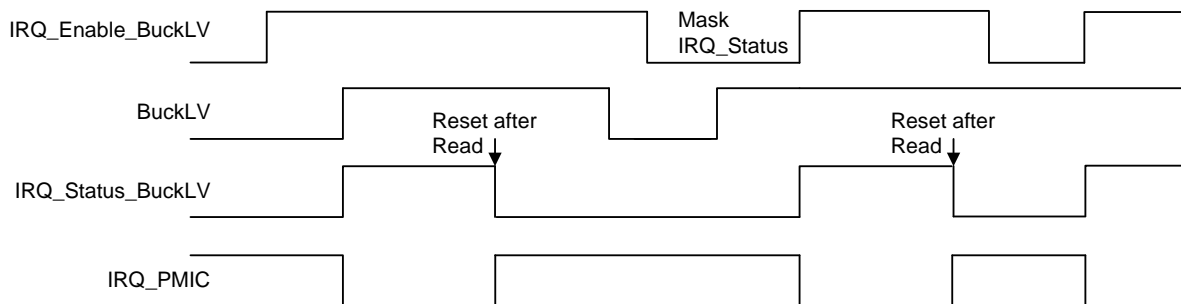

Waveform - (when the other IRQ_status are low)

* OTW125/OTW100 means the 125°C/100°C pre-warming over-temperature.

EEPROM (MTP) Control Flow

The RT5028F embeds 32 bytes MTP memory, and it allows users to save some I²C register bank data to MTP. When the I²C register 0x3A Bit[0]/Bit[1] is wrote to "1", the MTP Page1/Page2 will execute erase process firstly.

Because the erase process will be done in every writing time, the MTP data will be missed. So it would be best for users to read data from MTP to I²C first before executing writing process.

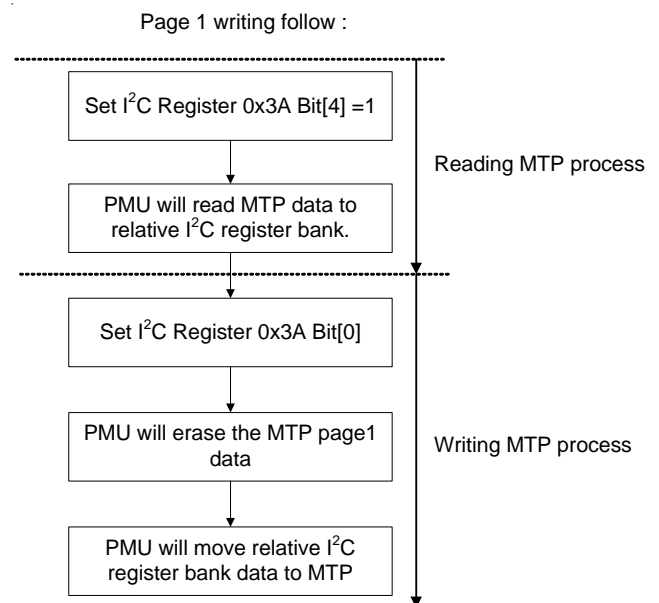

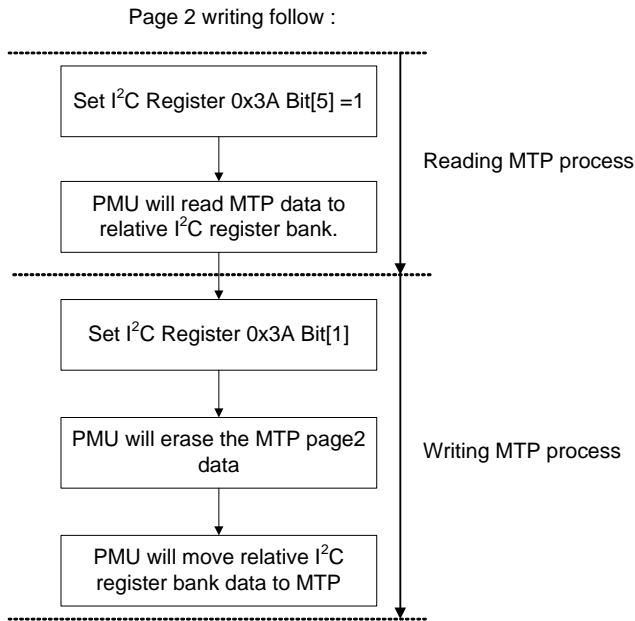

Thermal Considerations

The junction temperature should never exceed the absolute maximum junction temperature $T_{J(MAX)}$, listed under Absolute Maximum Ratings, to avoid permanent damage to the device. The maximum allowable power dissipation depends on the thermal resistance of the IC package, the PCB layout, the rate of surrounding airflow, and the difference between the junction and ambient temperatures. The maximum power dissipation can be calculated using the following formula :

$$P_{D(MAX)} = (T_{J(MAX)} - T_A) / \theta_{JA}$$

where $T_{J(MAX)}$ is the maximum junction temperature, T_A is the ambient temperature, and θ_{JA} is the junction-to-ambient thermal resistance.

For continuous operation, the maximum operating junction temperature indicated under Recommended Operating Conditions is 125°C. The junction-to-ambient thermal resistance, θ_{JA} , is highly package dependent. For a WQFN-56L 7x7 package, the thermal resistance, θ_{JA} , is 27°C/W on a standard JEDEC 51-7 high effective-thermal-conductivity four-layer test board. The maximum power dissipation at $T_A = 25^\circ\text{C}$ can be calculated as below :

$$P_{D(MAX)} = (125^\circ\text{C} - 25^\circ\text{C}) / (27^\circ\text{C/W}) = 3.7\text{W for a WQFN-56L 7x7 package.}$$

The maximum power dissipation depends on the operating ambient temperature for the fixed $T_{J(MAX)}$ and the thermal resistance, θ_{JA} . The derating curves in Figure 2 allows the designer to see the effect of rising ambient temperature on the maximum power dissipation.

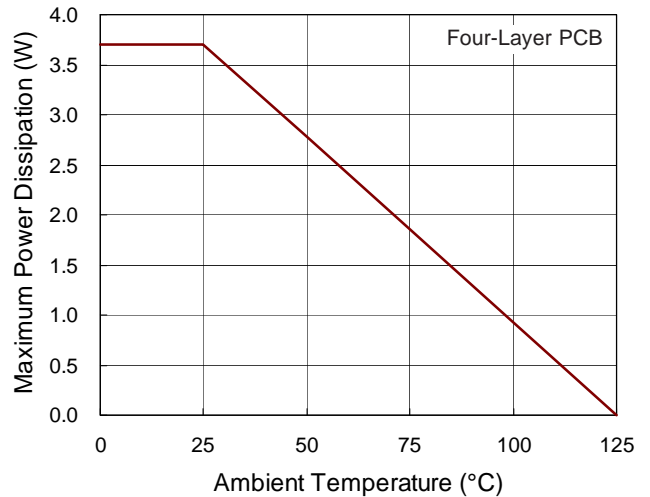

Figure 2. Derating Curve of Maximum Power Dissipation

Layout Consideration

For the best performance of the RT5028F, the following PCB layout guidelines must be strictly followed.

- ▶ Place the input and output capacitors as close as possible to the input and output pins respectively for good filtering.
- ▶ Keep the main power traces as wide and short as possible.
- ▶ The switching node area connected to LX and inductor should be minimized for lower EMI.
- ▶ Connect the GND and Exposed Pad to a strong ground plane for maximum thermal dissipation and noise protection.
- ▶ Directly connect the output capacitors to the feedback network of each channel to avoid bouncing caused by parasitic resistance and inductance from the PCB trace.

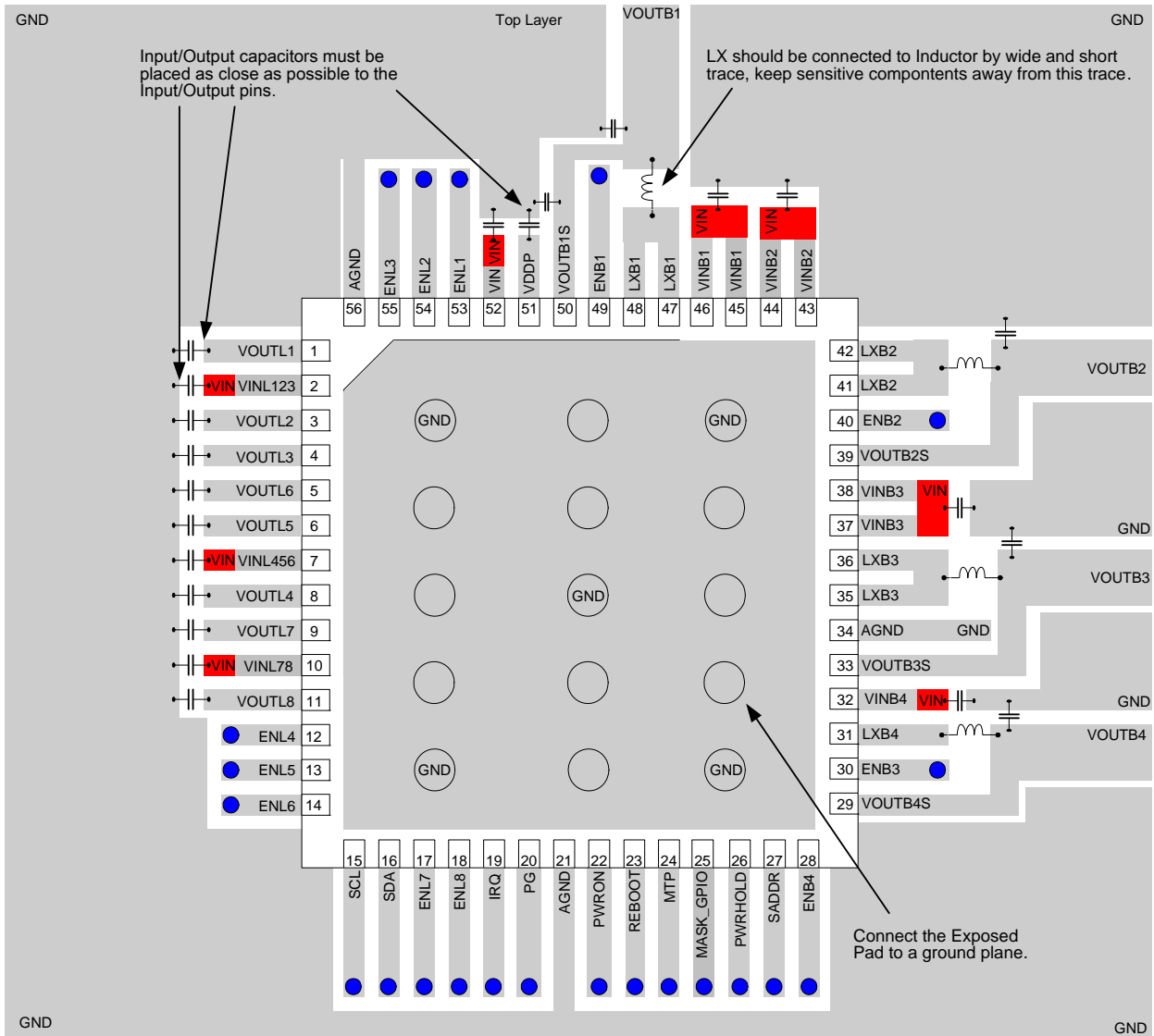

Figure 3. PCB Layout Guide

Table 3. I²C Register Table

Detail Description				
Address	00	Device ID		
Bit	Name	Description	Read/Write	Reset Value
[7:4]	VENDOR_ID	Vendor Identification : Telechips : 1000b	R	1000
[3:0]	CHIP_REV	Chip Revision	R	0111
Address	01	BUCKcontrol1		
Bit	Name	Description	R/W	Reset Value
[7:2]	Buck1Output[5:0]	Buck1 output voltage regulation 000000 : 0.7V, 25mV per step 000001 : 0.725V ... 101100 : 1.8V ... 111111 : 1.8V	R/W	Option
[1:0]	Buck1VRC	VRC setting 00 : 25mV/10μs, 01 : 50mV/10μs, 10 : 100mV/10μs, 11 : 200mV/10μs	R/W	Option
Address	02	BUCKcontrol2		
Bit	Name	Description	R/W	Reset Value
[7:2]	Buck2Output[5:0]	Buck2 output voltage regulation 000000 : 0.7V, 25mV per step 000001 : 0.725V ... 101100 : 1.8V ... 111111 : 1.8V	R/W	Option
[1:0]	Buck2VRC	VRC setting 00 : 25mV/10μs, 01 : 50mV/10μs, 10 : 100mV/10μs, 11 : 200mV/10μs	R/W	Option
Address	03	BUCKcontrol3		
Bit	Name	Description	R/W	Reset Value
[7:2]	Buck3Output[5:0]	Buck3 output voltage regulation 000000 : 0.7V, 50mV per step 000001 : 0.75V ... 111010 : 3.6V ... 111111 : 3.6V	R/W	Option
[1:0]	Buck3VRC	VRC setting 00 : 50mV/10μs, 01 : 100mV/10μs, 10 : 200mV/10μs, 11 : 400mV/10μs	R/W	Option

Address	04	BUCKcontrol4		
Bit	Name	Description	R/W	Reset Value
[7:2]	Buck4Output[5:0]	Buck4 output voltage regulation 000000 : 0.7V, 50mV per step 000001 : 0.75V ... 111010 : 3.6V ... 111111 : 3.6V	R/W	Option
[1:0]	Buck4VRC	VRC setting 00 : 50mV/10μs, 01 : 100mV/10μs, 10 : 200mV/10μs, 11 : 400mV/10μs	R/W	Option
Address	05	VRC Control		
Bit	Name	Description	R/W	Reset Value
7	Buck1VRC_EN	Buck1 VRC 0 : Disable - voltage ramps up to target voltage with one time 1 : Enable - voltage ramps up to target voltage with slope control	R/W	Option
6	Buck2VRC_EN	Buck2 VRC 0 : Disable - voltage ramps up to target voltage with one time 1 : Enable - voltage ramps up to target voltage with slope control	R/W	Option
5	Buck3VRC_EN	Buck3 VRC 0 : Disable - voltage ramps up to target voltage with one time 1 : Enable - voltage ramps up to target voltage with slope control	R/W	Option
4	Buck4VRC_EN	Buck4 VRC 0 : Disable - voltage ramps up to target voltage with one time 1 : Enable - voltage ramps up to target voltage with slope control	R/W	Option
[3:0]	Reserved		R/W	0000
Address	06	BUCK Mode		
Bit	Name	Description	R/W	Reset Value
7	Buck1mode	Buck1 mode 0 : Force PWM 1 : Auto Mode (PSM/PWM)	R/W	Option
6	Buck2mode	Buck2 mode 0 : Force PWM 1 : Auto Mode (PSM/PWM)	R/W	Option
5	Buck3mode	Buck3 mode 0 : Force PWM 1 : Auto Mode (PSM/PWM)	R/W	Option

4	Buck4mode	Buck4 mode 0 : Force PWM 1 : Auto Mode (PSM/PWM)	R/W	Option
3	Buck1oms	Buck1 output off mode state 0 : Floating 1 : Ground-discharged	R/W	Option
2	Buck2oms	Buck2 output off mode state 0 : Floating 1 : Ground-discharged	R/W	Option
1	Buck3oms	Buck3 output off mode state 0 : Floating 1 : Ground-discharged	R/W	Option
0	Buck4oms	Buck4 output off mode state 0 : Floating 1 : Ground-discharged	R/W	Option
Address	07	LDOcontrol1		
Bit	Name	Description	R/W	Reset Value
7	Reserved		R/W	0
[6:0]	LDO1OUT[6:0]	LDO1 output voltage regulation 0000000 : 1.6V, 25mV per step 0000001 : 1.625V ... 1010000 : 3.6V (MAX) ... 1111111 : 3.6V (MAX)	R/W	Option
Address	08	LDOcontrol2		
Bit	Name	Description	R/W	Reset Value
7	Reserved		R/W	0
[6:0]	LDO2OUT[6:0]	LDO2 output voltage regulation 0000000 : 1.6V, 25mV per step 0000001 : 1.625V ... 1010000 : 3.6V (MAX) ... 1111111 : 3.6V (MAX)	R/W	Option
Address	09	LDOcontrol3		
Bit	Name	Description	R/W	Reset Value
7	Reserved		R/W	0
[6:0]	LDO3OUT[6:0]	LDO3 output voltage regulation 0000000 : 1.6V, 25mV per step 0000001 : 1.625V ... 1010000 : 3.6V (MAX) ... 1111111 : 3.6V (MAX)	R/W	Option

Address	0A	LDOcontrol4		
Bit	Name	Description	R/W	Reset Value
7	Reserved		R/W	0
[6:0]	LDO4OUT[6:0]	LDO4 output voltage regulation 0000000 : 3 V, 25mV per step 0000001 : 3.025V ... 0011000 : 3.6V (MAX) ... 1111111 : 3.6V (MAX)	R/W	Option
Address	0B	LDOcontrol5		
Bit	Name	Description	R/W	Reset Value
7	Reserved		R/W	0
[6:0]	LDO5OUT[6:0]	LDO5 output voltage regulation 0000000 : 3V, 25mV per step 0000001 : 3.025V ... 0011000 : 3.6V (MAX) ... 1111111 : 3.6V (MAX)	R/W	Option
Address	0C	LDOcontrol6		
Bit	Name	Description	R/W	Reset Value
7	Reserved		R/W	0
[6:0]	LDO6OUT[6:0]	LDO6 output voltage regulation 0000000 : 3.0V, 25mV per step 0000001 : 3.025V ... 0011000 : 3.6V (MAX) ... 1111111 : 3.6V (MAX)	R/W	Option
Address	0D	LDOcontrol7		
Bit	Name	Description	R/W	Reset Value
7	Reserved		R/W	0
[6:0]	LDO7OUT[6:0]	LDO7 output voltage regulation 0000000 : 1.6V, 25mV per step 0000001 : 1.625V ... 1010000 : 3.6V (MAX) ... 1111111 : 3.6V (MAX)	R/W	Option

Address	0E	LDOcontrol8		
Bit	Name	Description	R/W	Reset Value
7	Reserved		R/W	0
[6:0]	LDO8OUT[6:0]	LDO8 output voltage regulation 0000000 : 1.6V, 25mV per step 0000001 : 1.625V ... 1010000 : 3.6V (MAX) ... 1111111 : 3.6V (MAX)	R/W	Option
Address	0F	LDOs off mode state		
Bit	Name	Description	R/W	Reset Value
7	LDO8oms	LDO8 output off mode state 0 : Floating 1 : Ground-discharged	R/W	1
6	LDO7oms	LDO7 output off mode state 0 : Floating 1 : Ground-discharged	R/W	1
5	LDO6oms	LDO6 output off mode state 0 : Floating 1 : Ground-discharged	R/W	1
4	LDO5oms	LDO5 output off mode state 0 : Floating 1 : Ground-discharged	R/W	1
3	LDO4oms	LDO4 output off mode state 0 : Floating 1 : Ground-discharged	R/W	1
2	LDO3oms	LDO3 output off mode state 0 : Floating 1 : Ground-discharged	R/W	1
1	LDO2oms	LDO2 output off mode state 0 : Floating 1 : Ground-discharged	R/W	1
0	LDO1ms	LDO1 output off mode state 0 : Floating 1 : Ground-discharged	R/W	1
Address	10	REBOOT/PWRHOLD delay time control		
Bit	Name	Description	R/W	Reset Value
[7:6]	Delayed2[1:0]	Delayed2 setting (00 : 100ms/01 : 500ms/10 : 1s/11 : 2s)	R/W	Option
[5:4]	Delayed1[1:0]	Delayed1 setting (00 : 100ms/01 : 500ms/10 : 1s/11 : 2s)	R/W	Option
[3:2]	THOLD[1:0]	THOLD setting (00 : 100ms/01 : 500ms/10 : 1s/11 : 2s)	R/W	Option
1	Reserved		R/W	0
0	DisTHOLD	Ignore THOLD Time. 0 : Keep PWRHOLD function. 1 : Ignore PWRHOLD function.	R/W	Option

Address	11	ON Event Setting		
Bit	Name	Description	R/W	Reset Value
[7:5]	On_Event	Powered on because of 000 : PWRON key-pressed 001 : VIN plugged in 010 : From REBOOT pin event 111 : No event happen	R	111
[4:0]	Reserved		R/W	0
Address	12	VIN UVLO/Buck On/Off		
Bit	Name	Description	R/W	Reset Value
[7:5]	VOFF setting	VIN UVLO 2.8V to 3.5V per 0.1V to power off PMIC (Hysteresis = VOFF setting + 0.35V) 000 : 2.8V 001 : 2.9V 010 : 3V 011 : 3.1V 100 : 3.2V 101 : 3.3V 110 : 3.4V 111 : 3.5V	R/W	Option
4	Reserved		R/W	0
3	Buck4	Buck4 control (0 : Disable Buck4/1 : Enable Buck4)	R/W	Option
2	Buck3	Buck3 control (0 : Disable Buck3/1 : Enable Buck3)	R/W	Option
1	Buck2	Buck2 control (0 : Disable Buck2/1 : Enable Buck2)	R/W	Option
0	Buck1	Buck1 control (0 : Disable Buck1/1 : Enable Buck1)	R/W	Option

Address	13	LDOs On/Off		
Bit	Name	Description	R/W	Reset Value
7	LDO8	LDO8 control (0 : Disable LDO8 / 1 : Enable LDO8)	R/W	Option
6	LDO7	LDO7 control (0 : Disable LDO7 / 1 : Enable LDO7)	R/W	Option
5	LDO6	LDO6 control (0 : Disable LDO6 / 1 : Enable LDO6)	R/W	Option
4	LDO5	LDO5 control (0 : Disable LDO5 / 1 : Enable LDO5)	R/W	Option
3	LDO4	LDO4 control (0 : Disable LDO4 / 1 : Enable LDO4)	R/W	Option
2	LDO3	LDO3 control (0 : Disable LDO3 / 1 : Enable LDO3)	R/W	Option
1	LDO2	LDO2 control (0 : Disable LDO2 / 1 : Enable LDO2)	R/W	Option
0	LDO1	LDO1 control (0 : Disable LDO1 / 1 : Enable LDO1)	R/W	Option

Address	14	PWRON(Power On Key) time Parameters Setting / PG delay		
Bit	Name	Description	R/W	Reset Value
[7:6]	START_TIME	Startup time setting 00 : 100μs (pressing time - low level) 01 : 100ms 10 : 1s 11 : 2s	R/W	Option
[5:4]	L_PRESS_TIME	Long-press time setting (after Power-On, 00 : 1s (falling edge to rising edge) 01 : 1.5s 10 : 2s 11 : 2.5s Sending short/long-press IRQ to CPU ex : 1.5s → low time < 1.5s (short IRQ) → low time > 1.5s but < 6s (shutdown time) (long IRQ) → low time > 6s (shutdown time) (shutdown)	R/W	Option
[3:2]	SHDN_PRESS	Key-press forced shutdown time setting 00 : 4s/0ms (pressing time : low level) 01 : 6s/1ms 10 : 8s/1ms 11 : 10s/2ms (allow option 0/1/1/2ms by SHDN_PRESS_SHORT)	R/W	Option
[1:0]	PG_DLY	PG signal delay after the last power startup is done 00 : 10ms 01 : 50ms 10 : 100ms 11 : 200ms/5ms (allow option 5ms by PG_DLY_5ms_EN)	R/W	Option

Address	15	SHDN Control		
Bit	Name	Description	Read/Write	Reset Value
7	SHDN_CTRL	Power off setting by CPU, after set, 100ms delayed power off 0 : Normal operation 1 : Disable the PMIC output	R/W	0
6	SHDN_TIMING	Disable Buck/LDO only for normal power off (SHDN_CTRL = 1) 0 : Disable at the same time 1 : Contrary to the startup timing (first_on-last_off)	R/W	Option
[5:4]	SHDN_DLYTIME	Delayed shutdown time after send the (PWRON)key-press-forced-shutdown IRQ (when IRQ is disable, there is no delay) 00 : 100ms 01 : 500ms 10 : 1s 11 : 2s	R/W	Option
3	Reserved		R/W	0
2	PG_DLY_5ms_EN	0 : 0x14[1:0] = 11, delay is 200ms 1 : 0x14[1:0] = 11, delay is 5ms	R/W	Option
1	SHDN_PRESS_SHORT	0 : 0x14[3:2], SHDN_PRESS time is 4s/6s/8s/10s 1 : 0x14[3:2], SHDN_PRESS time is 0ms/1ms/1ms/2ms	R/W	Option
0	PWRON_NORMOFF_EN	PWRON off sequence 0 : Disable this event. 1 : Enable this event	R/W	Option
Address	16	Powered off conditions enable setting		
Bit	Name	Description	Read/Write	Reset Value
7	BCK1LV_ENSHDN	Buck1 output voltage low SHDN 0 : Disable this event. 1 : Enable this event	R/W	0
6	BCK2LV_ENSHDN	Buck2 output voltage low SHDN 0 : Disable this event. 1 : Enable this event	R/W	0
5	BCK3LV_ENSHDN	Buck3 output voltage low SHDN 0 : Disable this event. 1 : Enable this event	R/W	0
4	BCK4LV_ENSHDN	Buck4 output voltage low SHDN 0 : Disable this event. 1 : Enable this event	R/W	0
3	PWRON_ENSHDN	PWRON key-pressed forced SHDN 0 : Disable this event. 1 : Enable this event	R/W	1
2	OT_ENSHDN	Over temperature SHDN 0 : Disable this event. 1 : enable this event	R/W	1
1	VINLV_ENSHDN	VIN voltage low (VOFF) SHDN 0 : Disable this event. 1 : Enable this event	R/W	Option
0	VINLV_SEQ_EN	Off sequence after VIN voltage low (VOFF) 0 : Disable this event. 1 : Enable this event	R/W	Option

Address	17	OFF Event (Only reset by POR)		
Bit	Name	Description	Read/Write	Reset Value
[7:4]	OFF_Event	Powered off because of (Only shows last power-off event) 0000 : VIN voltage low (VOFF) (Set by reg) 0001 : Buck1 output voltage low 0010 : Buck2 output voltage low 0011 : Buck3 output voltage low 0100 : PWRON key-pressed forced shutdown 0101 : Power Off register setting 0110 : Over-temperature event 0111 : Reboot restart. 1000 : Buck4 output voltage low 1001 : PWR_HOLD fail. 1010 : No event happen. 1111 : No event happen	R	1111
[3:0]	Reserved		R	0000
Address	28	IRQ Enable1		
Bit	Name	Description	Read/Write	Reset Value
7	OT_IRQ	Internal over-temperature was triggered, IRQ enable	R/W	1
6	Bck1LV_IRQ	Buck1 output voltage equal 66% x V _{Target} , IRQ enable	R/W	1
5	Bck2LV_IRQ	Buck2 output voltage equal 66% x V _{Target} , IRQ enable	R/W	1
4	Bck3LV_IRQ	Buck3 output voltage equal 66% x V _{Target} , IRQ enable	R/W	1
3	Bck4LV_IRQ	Buck4 output voltage equal 66% x V _{Target} , IRQ enable	R/W	1
2	PWRONSP_IRQ	PWRON short press, IRQ enable (32μs deglitch time)	R/W	0
1	PWRONLP_IRQ	PWRON long press, IRQ enable (32μs deglitch time)	R/W	0
0	SYSLV_IRQ	VIN voltage is lower than VOFF, IRQ enable	R/W	0

Address	29	IRQ Status1		
Bit	Name	Description	Read/Write	Reset Value
7	OT	Internal over-temperature	R	0
6	Bck1LV	Buck1 output voltage equal 66% x V _{Target}	R	0
5	Bck2LV	Buck2 output voltage equal 66% x V _{Target}	R	0
4	Bck3LV	Buck3 output voltage equal 66% x V _{Target}	R	0
3	Bck4LV	Buck4 output voltage equal 66% x V _{Target}	R	0
2	PWRONSP	PWRON short press (32μs deglitch time)	R	0
1	PWRONLP	PWRON long press (32μs deglitch time)	R	0
0	VINLV	VIN voltage is lower than VOFF	R	0
Address	2A	IRQ Enable2		
Bit	Name	Description	Read/Write	Reset Value
7	KPSHDN_IRQ	Key-press forced shutdown, IRQ enable	R/W	1
6	PWRONR_IRQ	PWRON press rising edge, IRQ enable	R/W	0
5	PWRONF_IRQ	PWRON press falling edge, IRQ enable	R/W	0
[4:0]	Reserved		R	0000
Address	2B	IRQ Status2		
Bit	Name	Description	Read/Write	Reset Value
7	KPSHDN	Key-press forced shutdown	R	0
6	PWRONR	PWRON press rising edge	R	0
5	PWRONF	PWRON press falling edge	R	0
[4:2]	Reserved		R	000
1	OTW125	Internal 125°C pre-warning over-temperature.	R	0
0	OTW100	Internal 100°C pre-warning over-temperature.	R	0
Address	2C	PMU On/Off Sequence1		
Bit	Name	Description (Setting on/off sequence priority) (0000 : off, 0001 : first on, 1100 : last on) (The sequence is planed by first on last off)	Read/Write	Reset Value
[7:4]	Buck2_Seq[3:0]	Setting Buck2 on/off sequence priority	R/W	Option
[3:0]	Buck1_Seq[3:0]	Setting Buck1 on/off sequence priority	R/W	Option
Address	2D	PMU On/Off Sequence2		
Bit	Name	Description (Setting on/off sequence priority) (0000 : off, 0001 : first on, 1100 : last on) (The sequence is planed by first on last off)	Read/Write	Reset Value
[7:4]	Buck4_Seq[3:0]	Setting Buck4 on/off sequence priority	R/W	Option
[3:0]	Buck3_Seq[3:0]	Setting Buck3 on/off sequence priority	R/W	Option

Address	2E	PMU On/Off Sequence3		
Bit	Name	Description (Setting on/off sequence priority) (0000 : off, 0001 : first on, 1100 : last on) (The sequence is planed by first on last off)	Read/Write	Reset Value
[7:4]	LDO2_Seq[3:0]	Setting LDO2 on/off sequence priority	R/W	Option
[3:0]	LDO1_Seq[3:0]	Setting LDO1 on/off sequence priority	R/W	Option
Address	2F	PMU On/Off Sequence4		
Bit	Name	Description (Setting on/off sequence priority) (0000 : off, 0001 : first on, 1100 : last on) (The sequence is planed by first on last off)	Read/Write	Reset Value
[7:4]	LDO4_Seq[3:0]	Setting LDO4 on/off sequence priority	R/W	Option
[3:0]	LDO3_Seq[3:0]	Setting LDO3 on/off sequence priority	R/W	Option
Address	30	PMU On/Off Sequence5		
Bit	Name	Description (Setting on/off sequence priority) (0000 : off, 0001 : first on, 1100 : last on) (The sequence is planed by first on last off)	Read/Write	Reset Value
[7:4]	LDO6_Seq[3:0]	Setting LDO6 on/off sequence priority	R/W	Option
[3:0]	LDO5_Seq[3:0]	Setting LDO5 on/off sequence priority	R/W	Option
Address	31	PMU On/Off Sequence5		
Bit	Name	Description (Setting on/off sequence priority) (0000 : off, 0001 : first on, 1100 : last on) (The sequence is planed by first on last off)	Read/Write	Reset Value
[7:4]	LDO8_Seq[3:0]	Setting LDO8 on/off sequence priority	R/W	Option
[3:0]	LDO7_Seq[3:0]	Setting LDO7 on/off sequence priority	R/W	Option
Address	32	Soft-Start Control		
Bit	Name	Description	Read/Write	Reset Value
[7:6]	Reserved		R	Option
[5:2]	Soft-Start End Control @ MASK_GPIO = 0 (External Enable pin define)	0000 : First turn on channel decide the PG_DLY time. 0001 : Buck1 decide the PG_DLY time. 0100 : Buck1 decide the PG_DLY time. 0101 : LDO1 decide the PG_DLY time. 1100 : LDO8 decide the PG_DLY time. 1111 : LDO8 decide the PG_DLY time.	R/W	Option
[1:0]	Soft-Start Voltage level / time soft-start control.	Voltage Level 00 : When output voltage arrives to 80% VTarget, next channel will turn on. Soft-start time interval (TSS) : 01 : 1ms 10 : 4ms 11 : 8ms	R/W	Option

Address	33	Buck Syn-Clock Control		
Bit	Name	Description	Read/Write	Reset Value
[7:6]	VCO_VRC	VCO input voltage slop. 00 : 25mV/10µs, 01: 25mV/20µs 10 : 25mV/40µs, 11: 25mV/80µs Note : The VCO's voltage input range is 0.375V to 1.8V and the output frequency is 500kHz to 2.18MHz.	R/W	Option
[5:0]	VCO_DVS	VCO input voltage DVS control 000000 : 0.375V (500kHz) 111001 : 1.8V (2MHz) 111111 : 1.8V (2MHz)	R/W	Option
Address	34	Buck Syn-Clock Spread Spectrum Control		
Bit	Name	Description	Read/Write	Reset Value
[7:1]	Reserved		R/W	0000000
0	SSOSC	Buck Clock Spread Spectrum Control 0 : Disable spread spectrum function. 1 : Turn on spread spectrum function.	R/W	Option
Address	3A	EEPROM (MTP) Control		
Bit	Name	Description	Read/Write	Reset Value
[7:6]	Reserved		R/W	00
5	MTP Page 2 Read	Read MTP Page 2	R	0
4	MTP Page 1 Read	Read MTP Page 1	R	0
[3:2]	Reserved		R/W	00
1	MTP Page 2 write	Write MTP Page 2, and MTP also needs to be logic high.	W	0
0	MTP Page 1 write	Write MTP Page 1, and MTP also needs to be logic high.	W	0

Table 4. I²C to MTP Mapping Table
MTP Page-1

I ² C Register Address		Bit7	Bit6	Bit5	Bit4	Bit3	Bit2	Bit1	Bit0
0x01	Function	BUCKcontrol1							
	Meaning	Buck1Output[5:0]						Buck1VRC	
	Read/Write	R/W	R/W	R/W	R/W	R/W	R/W	R/W	R/W
	Reset Condition	A	A	A	A	A	A	A	A
0x02	Function	BUCKcontrol2							
	Meaning	Buck2Output[5:0]						Buck2VRC	
	Read/Write	R/W	R/W	R/W	R/W	R/W	R/W	R/W	R/W
	Reset Condition	A	A	A	A	A	A	A	A
0x03	Function	BUCKcontrol3							
	Meaning	Buck3Output[5:0]						Buck3VRC	
	Read/Write	R/W	R/W	R/W	R/W	R/W	R/W	R/W	R/W
	Reset Condition	A	A	A	A	A	A	A	A
0x04	Function	BUCKcontrol4							
	Meaning	Buck4Output[5:0]						Buck4VRC	
	Read/Write	R/W	R/W	R/W	R/W	R/W	R/W	R/W	R/W
	Reset Condition	A	A	A	A	A	A	A	A
0x05	Function	VRC Control							
	Meaning	Buck1VRC_EN	Buck2VRC_EN	Buck3VRC_EN	Buck4VRC_EN	Reserved	Reserved	Reserved	Reserved
	Read/Write	R/W	R/W	R/W	R/W	R/W	R/W	R/W	R/W
	Reset Condition	A	A	A	A	A	A	A	A
0x06	Function	Buck Mode							
	Meaning	Buck1 mode	Buck2 mode	Buck3 mode	Buck4 mode	Buck1oms	Buck2oms	Buck3oms	Buck4oms
	Read/Write	R/W	R/W	R/W	R/W	R/W	R/W	R/W	R/W
	Reset Condition	A	A	A	A	A	A	A	A
0x07	Function	LDOcontrol1							
	Meaning	Reserved	LDO1OUT[6:0]						
	Read/Write	R/W	R/W	R/W	R/W	R/W	R/W	R/W	R/W
	Reset Condition	A	A	A	A	A	A	A	A
0x08	Function	LDOcontrol2							
	Meaning	Reserved	LDO2OUT[6:0]						
	Read/Write	R/W	R/W	R/W	R/W	R/W	R/W	R/W	R/W
	Reset Condition	A	A	A	A	A	A	A	A

I ² C Register Address		Bit7	Bit6	Bit5	Bit4	Bit3	Bit2	Bit1	Bit0
0x09	Function	LDOcontrol3							
	Meaning	Reserved	LDO3OUT[6:0]						
	Read/Write	R/W	R/W	R/W	R/W	R/W	R/W	R/W	R/W
	Reset Condition	A	A	A	A	A	A	A	A
0x0A	Function	LDOcontrol4							
	Meaning	Reserved	LDO4OUT[6:0]						
	Read/Write	R/W	R/W	R/W	R/W	R/W	R/W	R/W	R/W
	Reset Condition	A	A	A	A	A	A	A	A
0x0B	Function	LDOcontrol5							
	Meaning	Reserved	LDO5OUT[6:0]						
	Read/Write	R/W	R/W	R/W	R/W	R/W	R/W	R/W	R/W
	Reset Condition	A	A	A	A	A	A	A	A
0x0C	Function	LDOcontrol6							
	Meaning	Reserved	LDO6OUT[6:0]						
	Read/Write	R/W	R/W	R/W	R/W	R/W	R/W	R/W	R/W
	Reset Condition	A	A	A	A	A	A	A	A
0x0D	Function	LDOcontrol7							
	Meaning	Reserved	LDO7OUT[6:0]						
	Read/Write	R/W	R/W	R/W	R/W	R/W	R/W	R/W	R/W
	Reset Condition	A	A	A	A	A	A	A	A
0x0E	Function	LDOcontrol8							
	Meaning	Reserved	LDO8OUT[6:0]						
	Read/Write	R/W	R/W	R/W	R/W	R/W	R/W	R/W	R/W
	Reset Condition	A	A	A	A	A	A	A	A
0x10	Function	REBOOT/PWRHOLD delay time control							
	Meaning	Delayed2[1:0]		Delayed1[1:0]		THOLD		Reserved	DisTHOLD
	Read/Write	R/W	R/W	R/W	R/W	R/W	R/W	R/W	R/W
	Reset Condition	A	A	A	A	A	A	A	A
0x12	Function	VIN UVLO (update default value after power on)							
	Meaning	VOFF setting			Reserved	Reserved	Reserved	Reserved	Reserved
	Read/Write	R/W	R/W	R/W	R/W	R/W	R/W	R/W	R/W
	Reset Condition	A	A	A	A	B	B	B	B

MTP Page-2

I ² C Register Address		Bit7	Bit6	Bit5	Bit4	Bit3	Bit2	Bit1	Bit0
0x14	Function	PWRON time Parameters Setting / PG delay							
	Meaning	START_TIME		L_PRESS_TIME		SHDN_PRESS		PG_DLY	
	Read/Write	R/W	R/W	R/W	R/W	R/W	R/W	R/W	R/W
	Reset Condition	A	A	A	A	A	A	A	A
0x15	Function	SHDN Control							
	Meaning	Reserved	SHDN_TIMING	SHDN_DLYTIME		Reserved	PG_DLY_5ms_EN	SHDN_PRESS_SHORT	PWRON_NORMOFF_EN
	Read/Write	R/W	R/W	R/W	R/W	R/W	R/W	R/W	R/W
	Reset Condition	B	A	A	A	A	A	A	A
0x16	Function	Powered Off conditions enable setting							
	Meaning	Reserved	Reserved	Reserved	Reserved	Reserved	Reserved	VINLV_ENSHDN	VINLV_SEQ_EN
	Read/Write	R/W	R/W	R/W	R/W	R/W	R/W	R/W	R/W
	Reset Condition	A	A	A	A	A	A	A	A
0x2C	Function	PMU On/Off Sequence1							
	Meaning	Buck2_Seq[3:0]				Buck1_Seq[3:0]			
	Read/Write	R/W	R/W	R/W	R/W	R/W	R/W	R/W	R/W
	Reset Condition	A	A	A	A	A	A	A	A
0x2D	Function	PMU On/Off Sequence2							
	Meaning	Buck4_Seq[3:0]				Buck3_Seq[3:0]			
	Read/Write	R/W	R/W	R/W	R/W	R/W	R/W	R/W	R/W
	Reset Condition	A	A	A	A	A	A	A	A
0x2E	Function	PMU On/Off Sequence3							
	Meaning	LDO2_Seq[3:0]				LDO1_Seq[3:0]			
	Read/Write	R/W	R/W	R/W	R/W	R/W	R/W	R/W	R/W
	Reset Condition	A	A	A	A	A	A	A	A
0x2F	Function	PMU On/Off Sequence4							
	Meaning	LDO4_Seq[3:0]				LDO3_Seq[3:0]			
	Read/Write	R/W	R/W	R/W	R/W	R/W	R/W	R/W	R/W
	Reset Condition	A	A	A	A	A	A	A	A

I ² C Register Address	Bit7	Bit6	Bit5	Bit4	Bit3	Bit2	Bit1	Bit0	
0x30	Function	PMU On/Off Sequence5							
	Meaning	LDO6_Seq[3:0]				LDO5_Seq[3:0]			
	Read/Write	R/W	R/W	R/W	R/W	R/W	R/W	R/W	R/W
	Reset Condition	A	A	A	A	A	A	A	A
0x31	Function	PMU On/Off Sequence6							
	Meaning	LDO8_Seq[3:0]				LDO7_Seq[3:0]			
	Read/Write	R/W	R/W	R/W	R/W	R/W	R/W	R/W	R/W
	Reset Condition	A	A	A	A	A	A	A	A
0x32	Function	Soft-Start Control							
	Meaning	Reversed	Reversed	Soft-Start End Select @ MASK_GPIO = 1				Soft-Start Control	
	Read/Write	R/W	R/W	R/W	R/W	R/W	R/W	R/W	R/W
	Reset Condition	A	A	A	A	A	A	A	A
0x33	Function	Buck Syn-Clock Control							
	Meaning	VCO_VRC			VCO_DVS				
	Read/Write	R/W	R/W	R/W	R/W	R/W	R/W	R/W	R/W
	Reset Condition	A	A	A	A	A	A	A	A
0x34	Function	Buck Syn-Clock Spread Spectrum Control							
	Meaning	Reversed	Reversed	Reversed	Reversed	Reversed	Reversed	Reversed	SSOSC
	Read/Write	R/W	R/W	R/W	R/W	R/W	R/W	R/W	R/W
	Reset Condition	A	A	A	A	A	A	A	A

Reset Condition

A	Reset by MTP (Register 0x12 VOFF Setting).
B	Reset when VIN < 1.7V.

Table 5. MTP Code Table

Product No.	RT5028FGQW	RT5028FGQW-06
Code No.	05	06
Register	MTP Value	MTP Value
0x01	B0	B0
0x02	40	50
0x03	1C	1C
0x04	D0	D0
0x05	5	5
0x06	4F	4F
0x07	16	16

Code No.	05	06
Register	MTP Value	MTP Value
0x08	8	8
0x09	8	8
0x0A	0C	0C
0x0B	0C	0C
0x0C	0C	0C
0x0D	44	24
0x0E	44	44
0x10	61	61
0x12	CF	CF
0x14	40	40
0x15	49	49
0x16	0E	0E
0x2C	64	74
0x2D	53	53
0x2E	42	42
0x2F	54	54
0x30	16	19
0x31	78	86
0x32	2E	2E
0x33	39	39
0x34	0	0

Outline Dimension

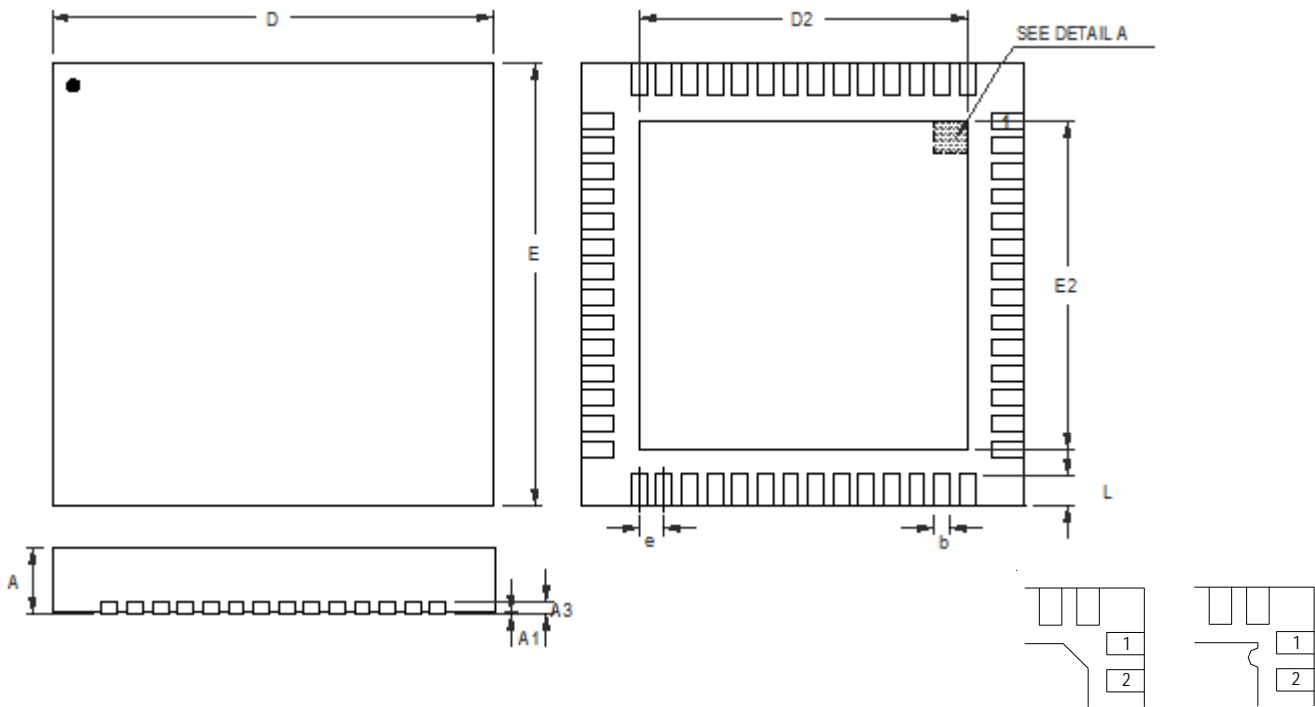

DETAIL A

Pin #1 ID and Tie Bar Mark Options

Note : The configuration of the Pin #1 identifier is optional, but must be located within the zone indicated.

Symbol	Dimensions In Millimeters		Dimensions In Inches	
	Min	Max	Min	Max
A	0.700	0.800	0.028	0.031
A1	0.000	0.050	0.000	0.002
A3	0.175	0.250	0.007	0.010
b	0.150	0.250	0.006	0.010
D	6.900	7.100	0.272	0.280
D2	5.150	5.250	0.203	0.207
E	6.900	7.100	0.272	0.280
E2	5.150	5.250	0.203	0.207
e	0.400		0.016	
L	0.350	0.450	0.014	0.018

W-Type 56L QFN 7x7 Package

Footprint Information

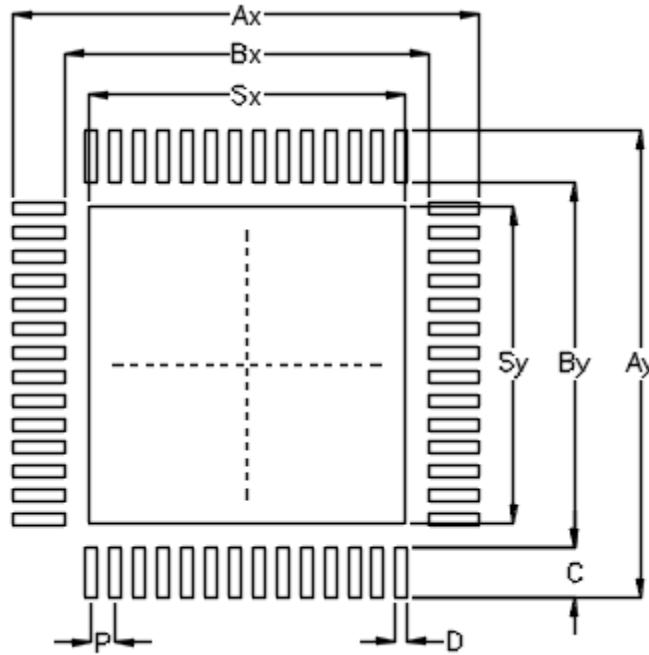

Package	Number of Pin	Footprint Dimension (mm)									Tolerance
		P	Ax	Ay	Bx	By	C	D	Sx	Sy	
V/W/U/XQFN7*7-56	56	0.40	7.80	7.80	6.10	6.10	0.85	0.20	5.30	5.30	±0.05

Richtek Technology Corporation

14F, No. 8, Tai Yuen 1st Street, Chupei City
 Hsinchu, Taiwan, R.O.C.
 Tel: (8863)5526789

Richtek products are sold by description only. Richtek reserves the right to change the circuitry and/or specifications without notice at any time. Customers should obtain the latest relevant information and data sheets before placing orders and should verify that such information is current and complete. Richtek cannot assume responsibility for use of any circuitry other than circuitry entirely embodied in a Richtek product. Information furnished by Richtek is believed to be accurate and reliable. However, no responsibility is assumed by Richtek or its subsidiaries for its use; nor for any infringements of patents or other rights of third parties which may result from its use. No license is granted by implication or otherwise under any patent or patent rights of Richtek or its subsidiaries.

Mouser Electronics

Authorized Distributor

Click to View Pricing, Inventory, Delivery & Lifecycle Information:

[Richtek:](#)

[RT5028FGQW](#)