

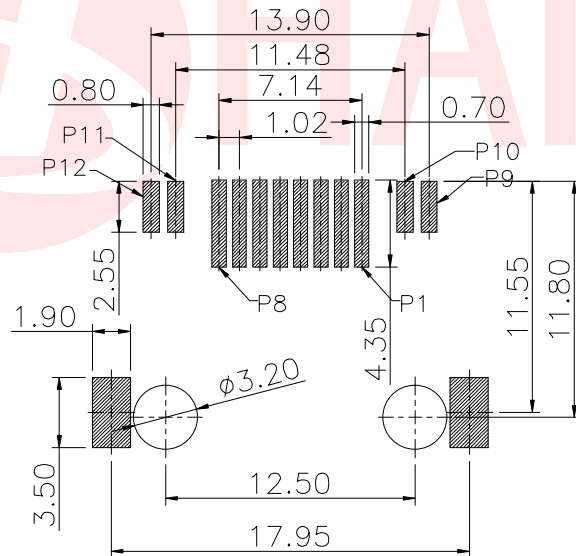

REV.	ECN NO OR DESCRIPTION	REVISED	DATE

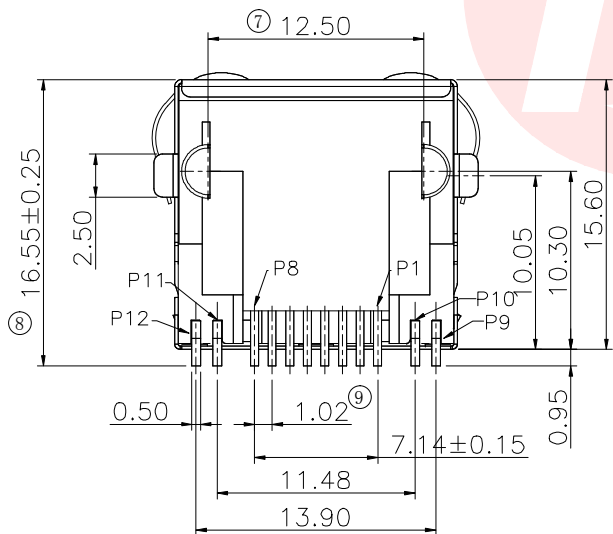
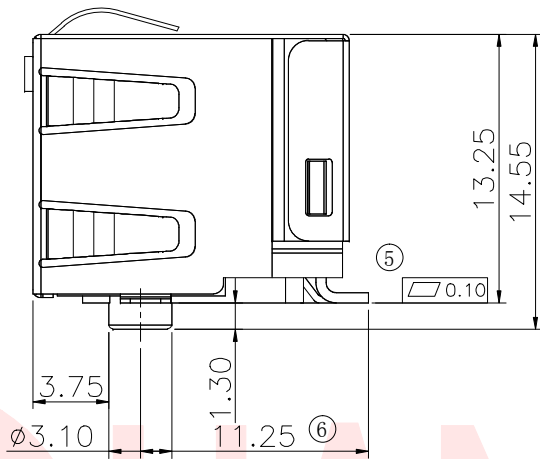
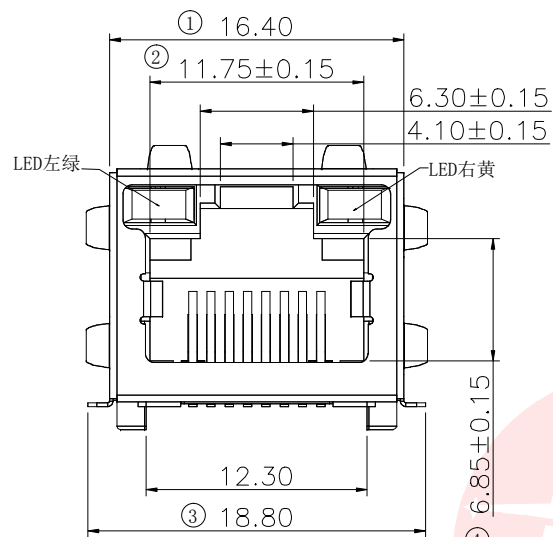

SPECIFICATION NOTES:

ELECTRICAL:

- VOLTAGE RATING: 125 VAC RMS
- CURRENT RATING: 1.5 AMP
- CONTACT RESISTANCE: 30m MAX.
- INSULATION RESISTANCE: 1000M MIN. AT500V DC.
- DIELECTRIC STRENGTH: 1000 V AC OR 1500V DC RMS AT 0.5mA 50 Hz / 60 Hz FOR 1MINUTE

MECHANICAL:

- HOUSING:LCP BLACK, UL 94V-0
- CONTACT:PHOSPHOR BRONZE T=0.30MM
- PLATING:GOLD PLATING AT CONTACT AREA, MATTE TIN AT TAIL 100U MIN., NICKEL 30U MIN. OVER ALL.
- SHELL:BRASS T=0.20
- OPERATING LIFE:750 CYCLES MIN.
- MATING/UNMATING FORCE: 30N/3.06KGf MAX.
- RETENTION STRENGTH:50N OR 30N MIN.FOR 60S±5S

ENVIRONMENTAL:

- STORAGE:-40°C TO +85°C RELATIVE HUMIDITY<80%
- GUARANTEE PERIOD:12 MONTHS
- OPERATION: -40°C TO +85°C
- MANUAL SOLDERING PARAMETERS:24H IR TEMPERATURE: 260±5°C 5~10 SECONDS.

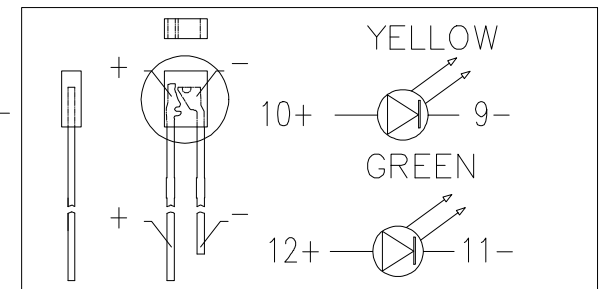
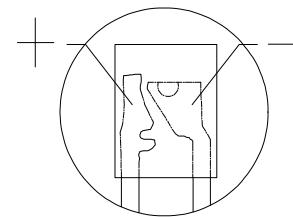

RECOMMENDED PCB LAYOUT

PTOLERANCE=±0.05

UNLESS OTHERWISE SPECIFIED TOLERANCES

DECIMALS:	ANGLES:
X :±0.30	X :±2°
X.X :±0.20	X.X :±1°
X.XX :±0.10	



东莞市汉博电子科技有限公司
DONGGUAN HANBO TECHNOLOGY CO., LTD

TITLE	RJ45 LED SMT 8P8C 带弹带灯左绿右黄		
DWN	xiong	PART NO. RJ45-884-810-2	
CHKD	lee	SCALE:1:1	UNIT: mm
APVD	wang	SIZE: A4	SHEET:10F 1
REV: A4			
CUSTOMER COPY			