

## 5-V DUAL RS-232 LINE DRIVER/RECEIVER WITH ±15-kV ESD PROTECTION

### Features

- ESD Protection for RS-232 Bus Pins ±15kV – Human-Body Model
- Meets or Exceeds the Requirements of TIA/EIA-232-F and ITU v.28 Standards
- Operates at 5-V VCC Supply
- Operates Up To 120 kbit/s
- External Capacitors . . . 4 × 0.1μF
- Latch-Up Performance Exceeds 100mA Per JESD 78, Class II

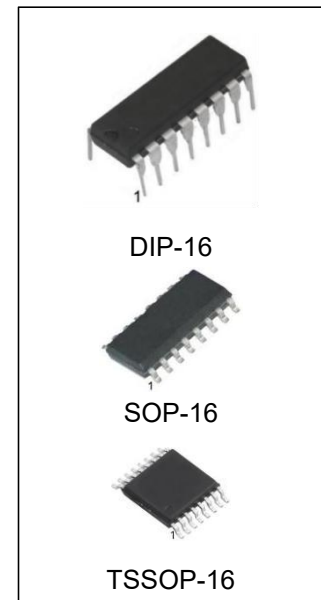

### Applications

Battery-Powered Systems, PDAs, Notebooks, Laptops, Palmtop PCs, and Hand-Held Equipment

### Ordering Information

DEVICE	Package Type	MARKING	Packing	Packing Qty
HGX202EIN	DIP-16	HGX202EI	TUBE	1000pcs/box
HGX202ECN	DIP-16	HGX202EC	TUBE	1000pcs/box
HGX202EIM/TR	SOP-16	HGX202EI	REEL	2500pcs/reel
HGX202ECM/TR	SOP-16	HGX202EC	REEL	2500pcs/reel
HGX202EIMT/TR	TSSOP-16	X202EI	REEL	2500pcs/reel
HGX202ECMT/TR	TSSOP-16	X202EC	REEL	2500pcs/reel

### General Description

The HGX202 device consists of two line drivers, two line receivers, and a dual charge-pump circuit with ±15-kV ESD protection pin to pin (serial-port connection pins, including GND). The device meets the requirements of TIA/EIA-232-F and provides the electrical interface between an asynchronous communication controller and the serial-port connector. The charge pump and four small external capacitors allow operation from a single 5-V supply. The device operates at data signaling rates up to 120 kbit/s and a maximum of 30-V/μs driver output slew rate.

## PIN Configuration

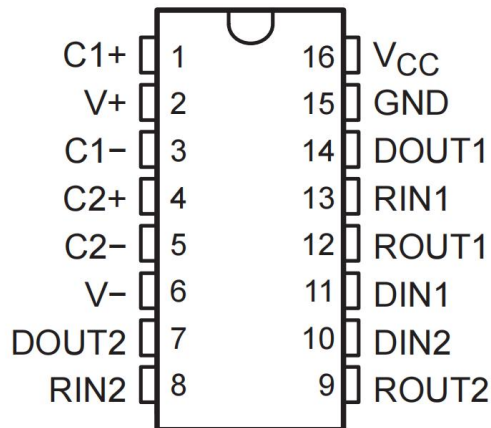

DIP-16/SOP-16/TSSOP-16

## Function Tables

EACH DRIVER

INPUT DIN	OUTPUT DOUT
L	H
H	L

H = high level, L = low level

EACH RECEIVER

INPUT DIN	OUTPUT DOUT
L	H
H	L
Open	H

H = high level, L = low level, Open=input disconnected or connected driver off

## Logic Diagram (positive logic)

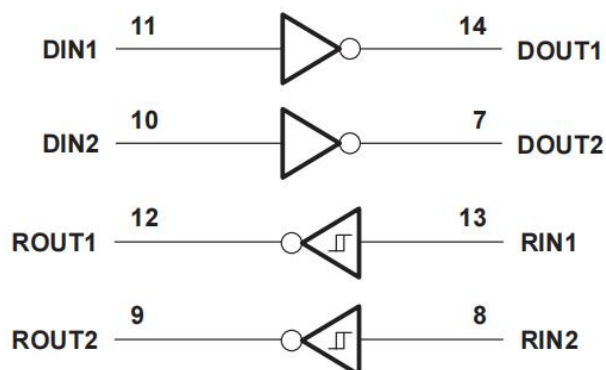

## Absolute Maximum Ratings

over operating free-air temperature range (unless otherwise noted)†

Condition		Min	Max
Supply voltage range, $V_{CC}$ (see Note 1)		-0.3V	6V
Positive charge pump voltage range, $V+$ (see Note 1)		$V_{CC}-0.3V$	14V
Negative charge pump voltage range, $V-$ (see Note 1)		-14V	0.3V
Input voltage range, $V_I$	Drivers	-0.3V	$V++0.3V$
	Receivers	-30V	+30V
Output voltage range, $V_O$	Drivers	$V- -0.3V$	$V+ +0.3V$
	Receivers	-0.3V	$V_{CC}+0.3V$
Short-circuit duration: $D_{OUT}$		Continuous	
Package thermal impedance, $\theta_{JA}$ (see Notes 2 and 3):	SOP package	73°C/W	-
	DIP package	67°C/W	-
Operating virtual junction temperature, $T_J$		-	150°C/W
Storage temperature range, $T_{stg}$		-65°C/W	150°C/W
Lead Temperature (Soldering, 10 seconds)		-	260°C

† Stresses beyond those listed under “absolute maximum ratings” may cause permanent damage to the device. These are stress ratings only, and functional operation of the device at these or any other conditions beyond those indicated under “recommended operating conditions” is not implied. Exposure to absolute-maximum-rated conditions for extended periods may affect device reliability.

### NOTES:

- All voltages are with respect to network GND.
- Maximum power dissipation is a function of  $T_J(\max)$ ,  $\theta_{JA}$ , and  $T_A$ . The maximum allowable power dissipation at any allowable ambient temperature is  $P_D = (T_J(\max) - T_A)/\theta_{JA}$ . Operating at the absolute maximum  $T_J$  of 150°C can affect reliability.
- The package thermal impedance is calculated in accordance with JESD 51-7.

## Recommended Operating Conditions

(see Note 4 and Figure 4)

			MIN	NOM	MAX	UNIT
Supply voltage			4.5	5	5.5	V
$V_{IH}$	Driver high-level input voltage	$D_{IN}$	2			V
$V_{IL}$	Driver low-level input voltage	$D_{IN}$	0.8			V
$V_I$	Driver input voltage		0	5.5		V
	Receiver input voltage		-30	30		
$T_A$	Operating free-air temperature		HGX202C	0	70	°C
			HGX202I	-40	85	

NOTE 4: Test conditions are  $C1-C4 = 0.1\mu F$  at  $V_{CC} = 5V \pm 0.5V$ .

### Electrical Characteristics

over recommended ranges of supply voltage and operating free-air temperature (unless otherwise noted) (see Note 4 and Figure 4)

PARAMETER		TEST CONDITIONS	MIN	TYP	MAX	UNIT
$I_{CC}$	Supply current	No load, $V_{CC} = 5V$		8	15	mA

All typical values are at  $V_{CC} = 5V$ , and  $T_A = 25^\circ C$ .

NOTE 4: Test conditions are  $C1-C4 = 0.1\mu F$  at  $V_{CC} = 5V \pm 0.5V$ .

## Electrical Characteristics

over recommended ranges of supply voltage and operating free-air temperature (unless otherwise noted) (see Note 4 and Figure 4)

PARAMETER	TEST CONDITIONS	MIN	TYP	MAX	UNIT		
V <sub>OH</sub>	High-level output voltage	D <sub>OUT</sub> at R <sub>L</sub> = 3 kΩ to GND, D <sub>IN</sub> = GND		5	9	V	
V <sub>OL</sub>	Low-level output voltage	D <sub>OUT</sub> at R <sub>L</sub> = 3 kΩ to GND, D <sub>IN</sub> = V <sub>CC</sub>		-5	-9	V	
I <sub>IH</sub>	High-level input current	V <sub>I</sub> = V <sub>CC</sub>			15	200	μA
I <sub>IL</sub>	Low-level input current	V <sub>I</sub> at 0 V			-15	200	μA
I <sub>OS‡</sub>	Short-circuit output current	V <sub>CC</sub> = 5.5 V, V <sub>O</sub> = 0 V			±10	±60	mA
r <sub>o</sub>	Output resistance	V <sub>CC</sub> , V <sub>+</sub> , and V <sub>-</sub> = 0 V, V <sub>O</sub> = ±2 V		300		Ω	

All typical values are at V<sub>CC</sub> = 5 V, and T<sub>A</sub> = 25°C.

‡ Short-circuit durations should be controlled to prevent exceeding the device absolute power-dissipation ratings, and not more than one output should be shorted at a time.

NOTE 4: Test conditions are C1–C4 = 0.1 μF at V<sub>CC</sub> = 5 V ± 0.5 V.

## Switching Characteristics

over recommended ranges of supply voltage and operating free-air Temperature (unless otherwise noted) (see Note 4 and Figure 4)

PARAMETER	TEST CONDITIONS	MIN	TYP	MAX	UNIT		
Maximum data rate	CL = 50 to 1000 pF, RL = 3 kΩ to 7 kΩ, One DOUT switching, See Figure 1	120			kbit/s		
t <sub>PLH(D)</sub>	Propagation delay time, low- to high-level output	CL = 2500 pF, RL = 3 kΩ, All drivers loaded, See Figure 1		2	μs		
t <sub>PHL(D)</sub>	Propagation delay time, high- to low-level output	CL = 2500 pF, RL = 3 kΩ, All drivers loaded, See Figure 1		2	μs		
t <sub>sk(p)</sub>	Pulse skew§	CL = 150 pF to 2500 pF, RL = 3 kΩ to 7 kΩ, See Figure 2		300	ns		
SR(tr)	Slew rate, transition region (see Figure 1)	CL = 50 pF to 1000 pF, RL = 3 kΩ to 7 kΩ, V <sub>CC</sub> = 5 V		3	6	30	V/μs

All typical values are at V<sub>CC</sub> = 5 V, and T<sub>A</sub> = 25°C.

§ Pulse skew is defined as |t<sub>PLH</sub> - t<sub>PHL</sub>| of each channel of the same device.

NOTE 4: Test conditions are C1–C4 = 0.1 μF at V<sub>CC</sub> = 5 V ± 0.5 V.

## ESD protection

PIN	PIN TEST CONDITIONS	TYP	UNIT
D <sub>OUT</sub> , R <sub>IN</sub>	Human-Body Model	±15	kV

## RECEIVER SECTION

### Electrical Characteristics

over recommended ranges of supply voltage and operating free-air temperature (unless otherwise noted) (see Note 4 and Figure 4)

PARAMETER		TEST CONDITIONS	MIN	TYP	MAX	UNIT
VOH	High-level output voltage	IOH = -1 mA	3.5V	V <sub>CC</sub> -0.4 V		V
VOL	Low-level output voltage	IOL = 1.6 mA		0.4		V
VIT+	Positive-going input threshold voltage	V <sub>CC</sub> = 5 V, TA = 25°C		1.7	2.4	V
VIT-	Negative-going input threshold voltage	V <sub>CC</sub> = 5 V, TA = 25°C	0.8	1.2		V
V <sub>hys</sub>	Input hysteresis (VIT+ - VIT-)		0.2	0.5	1	V
ri	Input resistance	VI = ±3 V to ±25 V	3	5	7	kΩ

All typical values are at V<sub>CC</sub> = 5 V, and TA = 25°C.

NOTE 4: Test conditions are C1-C4 = 0.1μF at V<sub>CC</sub> = 5 V ± 0.5 V.

### Switching Characteristics

over recommended ranges of supply voltage and operating free-air temperature (unless otherwise noted) (see Note 4 and Figure 3)

PARAMETER		TEST CONDITIONS	MIN	TYP	MAX	UNIT
t <sub>PLH(R)</sub>	Propagation delay time, low- to high-level output	C <sub>L</sub> = 150 pF		0.5	10	μs
t <sub>PHL(R)</sub>	Propagation delay time, high- to low-level output	C <sub>L</sub> = 150 pF		0.5	10	μs
tsk(p)	Pulse skew‡			300		ns

All typical values are at V<sub>CC</sub> = 5 V, and TA = 25°C.

‡ Pulse skew is defined as |t<sub>PLH</sub> - t<sub>PHL</sub>| of each channel of the same device.

NOTE 4: Test conditions are C1-C4 = 0.1μF, at V<sub>CC</sub> = 5 V ± 0.5 V.

**PARAMETER MEASUREMENT INFORMATION**

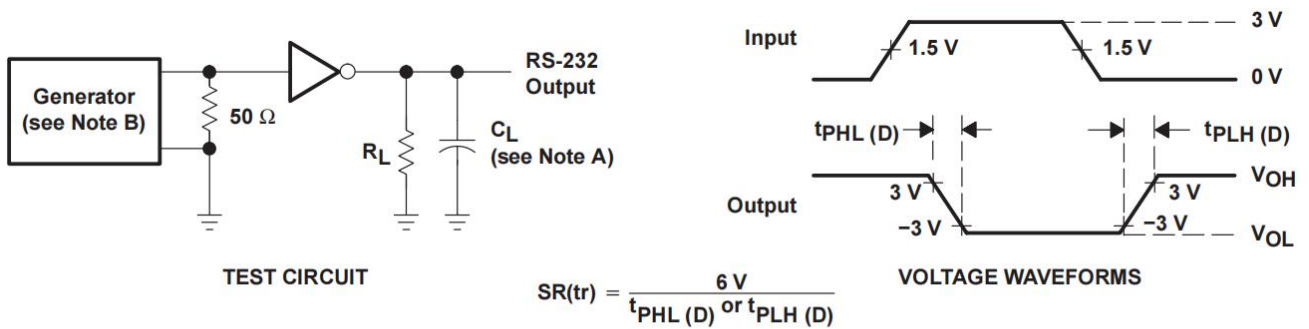

NOTES: A.  $C_L$  includes probe and jig capacitance.  
 B. The pulse generator has the following characteristics: PRR = 120 kbit/s,  $Z_O = 50 \Omega$ , 50% duty cycle,  $t_r \leq 10 \text{ ns}$ ,  $t_f \leq 10 \text{ ns}$ .

**Figure 1. Driver Slew Rate**

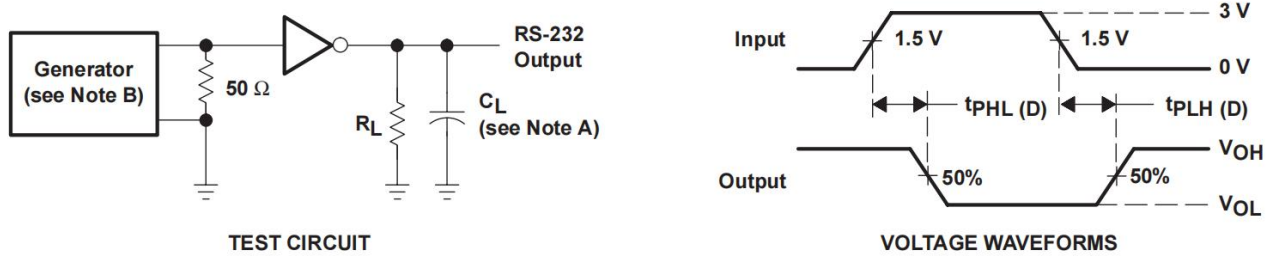

NOTES: A.  $C_L$  includes probe and jig capacitance.  
 B. The pulse generator has the following characteristics: PRR = 120 kbit/s,  $Z_O = 50 \Omega$ , 50% duty cycle,  $t_r \leq 10 \text{ ns}$ ,  $t_f \leq 10 \text{ ns}$ .

**Figure 2. Driver Pulse Skew**

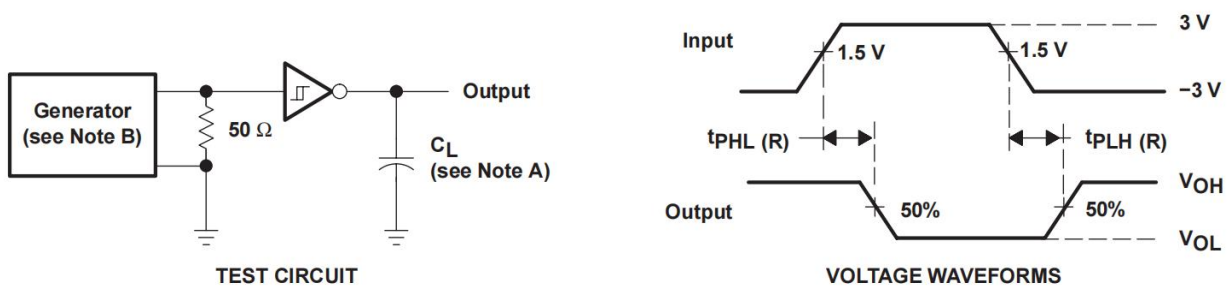

NOTES: A.  $C_L$  includes probe and jig capacitance.  
 B. The pulse generator has the following characteristics:  $Z_O = 50 \Omega$ , 50% duty cycle,  $t_r \leq 10 \text{ ns}$ ,  $t_f \leq 10 \text{ ns}$ .

**Figure 3. Receiver Propagation Delay Times**

**APPLICATION INFORMATION**

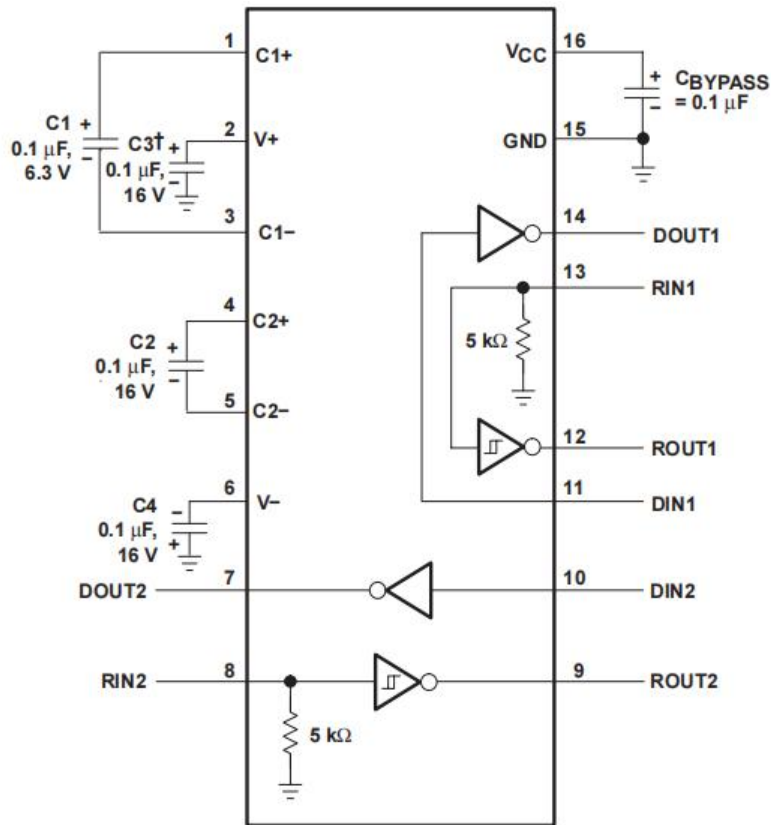

† C3 can be connected to V<sub>CC</sub> or GND.

NOTES: A. Resistor values shown are nominal.

- B. Nonpolarized ceramic capacitors are acceptable. If polarized tantalum or electrolytic capacitors are used, they should be connected as shown.

**Figure 4. Typical Operating Circuit and Capacitor Values**

## APPLICATION INFORMATION

### Capacitor Selection

The capacitor type used for C1–C4 is not critical for proper operation. The HGX202 requires 0.1- $\mu\text{F}$  capacitors, although capacitors up to 10  $\mu\text{F}$  can be used without harm. Ceramic dielectrics are suggested for the 0.1- $\mu\text{F}$  capacitors. When using the minimum recommended capacitor values, make sure the capacitance value does not degrade excessively as the operating temperature varies. If in doubt, use capacitors with a larger (e.g., 2 $\times$ ) nominal value. The capacitors' effective series resistance (ESR), which usually rises at low temperatures, influences the amount of ripple on V+ and V-.

Use larger capacitors (up to 10  $\mu\text{F}$ ) to reduce the output impedance at V+ and V-.

Bypass  $V_{\text{CC}}$  to ground with at least 0.1  $\mu\text{F}$ . In applications sensitive to power-supply noise generated by the charge pumps, decouple  $V_{\text{CC}}$  to ground with a capacitor the same size as (or larger than) the charge-pump capacitors (C1–C4).

### ESD protection

HGX202 devices have standard ESD protection structures incorporated on the pins to protect against electrostatic discharges encountered during assembly and handling. In addition, the RS232 bus pins (driver outputs and receiver inputs) of these devices have an extra level of ESD protection. Advanced ESD structures were designed to successfully protect these bus pins against ESD discharge of  $\pm 15\text{-kV}$  when powered down.

### Human-Body Model (HBM)

The HBM of ESD testing is shown in Figure 5. Figure 6 shows the current waveform that is generated during a discharge into a low impedance. The model consists of a 100-pF capacitor, charged to the ESD voltage of concern, and subsequently discharged into the device under test (DUT) through a 1.5-k $\Omega$  resistor.

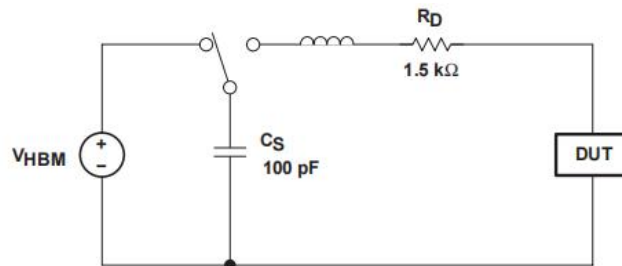

Figure 5. HBM ESD Test Circuit

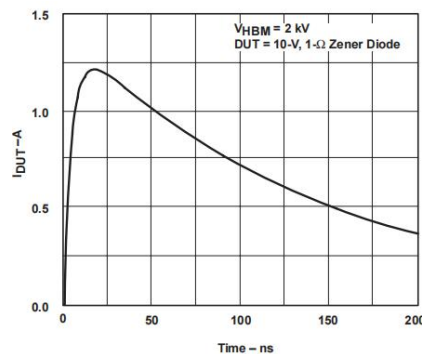

Figure 6. Typical HBM Current Waveform

---

**Machine Model (MM)**

The MM ESD test applies to all pins using a 200-pF capacitor with no discharge resistance. The purpose of the MM test is to simulate possible ESD conditions that can occur during the handling and assembly processes of manufacturing. In this case, ESD protection is required for all pins, not just RS-232 pins. However, after PC board assembly, the MM test no longer is as pertinent to the RS-232 pins.

**PHYSICAL DIMENSIONS**

DIP-16

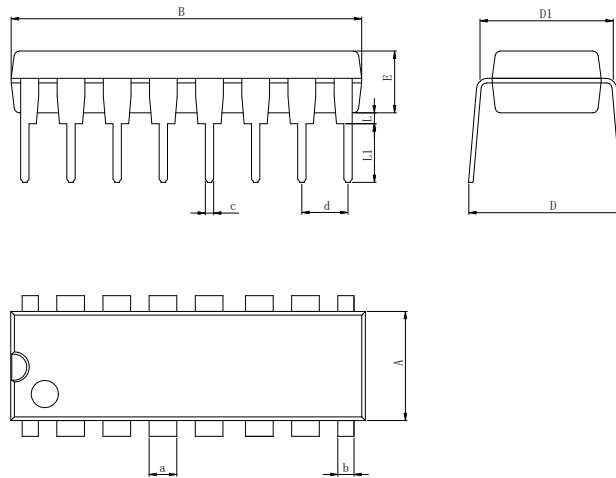

Dimensions In Millimeters(DIP-16)											
Symbol:	A	B	D	D1	E	L	L1	a	b	c	d
Min:	6.10	18.94	8.10	7.42	3.10	0.50	3.00	1.50	0.85	0.40	2.54 BSC
Max:	6.68	19.56	10.9	7.82	3.55	0.70	3.60	1.55	0.90	0.50	

SOP-16

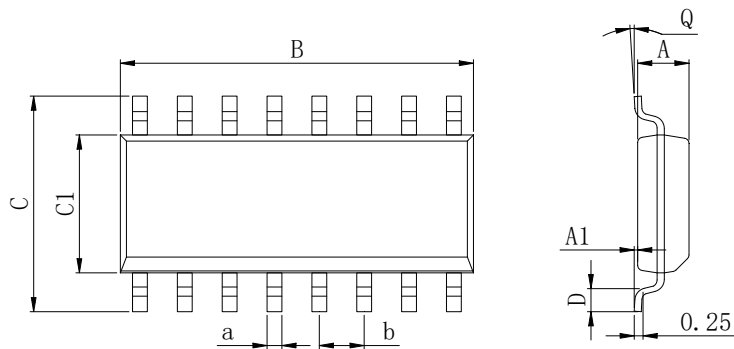

Dimensions In Millimeters(SOP-16)									
Symbol:	A	A1	B	C	C1	D	Q	a	b
Min:	1.35	0.05	9.80	5.80	3.80	0.40	0°	0.35	1.27 BSC
Max:	1.55	0.20	10.0	6.20	4.00	0.80	8°	0.45	

**PHYSICAL DIMENSIONS**

TSSOP-16

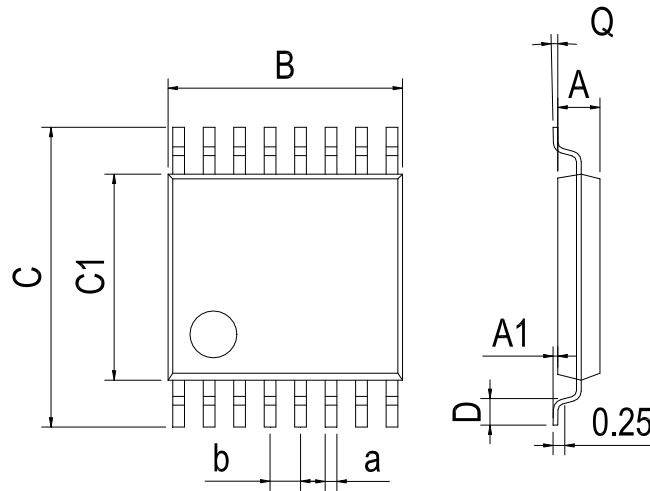

Dimensions In Millimeters(TSSOP-16)									
Symbol:	A	A1	B	C	C1	D	Q	a	b
Min:	0.85	0.05	4.90	6.20	4.30	0.40	0°	0.20	0.65 BSC
Max:	0.95	0.20	5.10	6.60	4.50	0.80	8°	0.25	

## Revision History

DATE	REVISION	PAGE
2013-4-9	New	1-13
2023-8-29	Modify the package dimension diagram TSSOP-16、 Updated DIP-16 dimension	10、 11
2024-11-7	Update Lead Temperature	3

---

**IMPORTANT STATEMENT:**

Huaguan Semiconductor reserves the right to change its products and services without notice. Before ordering, the customer shall obtain the latest relevant information and verify whether the information is up to date and complete. Huaguan Semiconductor does not assume any responsibility or obligation for the altered documents.

Customers are responsible for complying with safety standards and taking safety measures when using Huaguan Semiconductor products for system design and machine manufacturing. You will bear all the following responsibilities: Select the appropriate Huaguan Semiconductor products for your application; Design, validate and test your application; Ensure that your application meets the appropriate standards and any other safety, security or other requirements. To avoid the occurrence of potential risks that may lead to personal injury or property loss.

Huaguan Semiconductor products have not been approved for applications in life support, military, aerospace and other fields, and Huaguan Semiconductor will not bear the consequences caused by the application of products in these fields. All problems, responsibilities and losses arising from the user's use beyond the applicable area of the product shall be borne by the user and have nothing to do with Huaguan Semiconductor, and the user shall not claim any compensation liability against Huaguan Semiconductor by the terms of this Agreement.

The technical and reliability data (including data sheets), design resources (including reference designs), application or other design suggestions, network tools, safety information and other resources provided for the performance of semiconductor products produced by Huaguan Semiconductor are not guaranteed to be free from defects and no warranty, express or implied, is made. The use of testing and other quality control technologies is limited to the quality assurance scope of Huaguan Semiconductor. Not all parameters of each device need to be tested.

The documentation of Huaguan Semiconductor authorizes you to use these resources only for developing the application of the product described in this document. You have no right to use any other Huaguan Semiconductor intellectual property rights or any third party intellectual property rights. It is strictly forbidden to make other copies or displays of these resources. You should fully compensate Huaguan Semiconductor and its agents for any claims, damages, costs, losses and debts caused by the use of these resources. Huaguan Semiconductor accepts no liability for any loss or damage caused by infringement.